

Table of Contents

Introduction.....	iii
How to Use this Manual.....	iv
1.0 Simple 3D Modeling	1
1.1 Extrusions.....	1
1.2 Multiple Extrude.....	7
1.3 Simple Cafe Table	13
1.4 Setting 3D Views	19
1.5 Simple Solid Modeling.....	23
1.6 Loft Surface	29
Loft with Rail.....	37
Loft with Two Rails.....	39
1.7 Protrusion/Cutout Tool.....	45
1.9 Working Planes	56
1.10 Shell Solid	64
1.11 Duplicate and Extrude along a Path.....	66
1.12 Create Surface from Curves.....	71
1.13 Create Contours	76
2.0 Architectural Modeling	83
2.1 Create the Site	83
2.2 Working Planes	93
2.3 Extracting Surfaces	102
3.0 Bus Stop Project.....	107
3.1 Project Setup.....	107
3.2 Street Bollard.....	109
3.3 Trash Can.....	123
3.4 Building the Bus Stop.....	135
3.5 Building the Scene	159

1.0 Simple 3D Modeling

1.1 Extrusions

To create an extrusion start with a solid 2D element—for example, a rectangle, a circle, etc. If you want to render the object, it has to be a solid object before you extrude it. It can be a line, rectangle, polygon, or any 2D shape.

Extrusions follow a few rules:

1. Extrusions are always based on the viewing plane. They seem to come out of the screen at you. If you are in Top/Plan or Top, the extrusion will be in the Z direction only. If you are in a front view, the extrusion will be in the Y direction only.
2. Extrusions always start at 0 on the current working plane. If you haven't set a working plane, then the extrusion will start at Z=0 on the current layer.
3. The extrusion is based on the 2D shape and this 2D shape is stored by Vectorworks. You can use the command Edit Extrude from the Modify Menu to edit the 2D shape and change the extrusion or double click on the extrude to edit the 2D geometry.
4. You can edit the length of the extruded shape using the Object Info Palette.
5. You can edit the 3D location of the extruded shape using the Object Info Palette.

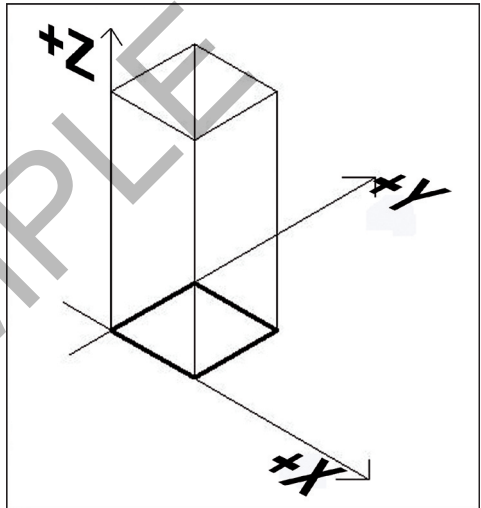

Extrusion Exercise 1



The first rule of extrusions is that extrusions always come out of the screen at you. This means that you have to be aware of the view that you are in before you choose the extrude command.

- Open the file **3D Model 1.sta** from the exercise folder.
- There are three equal rectangles in the middle of the drawing.

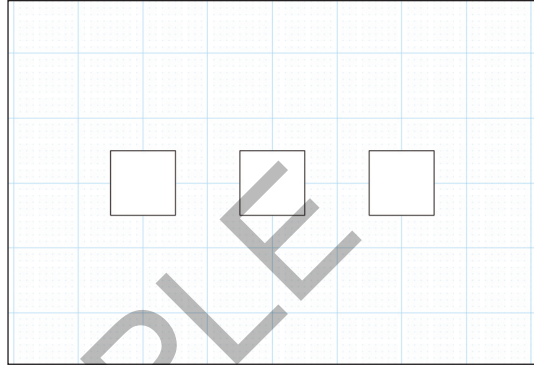

- Make sure that you are in a Top/Plan view.
- Go to the View Bar.
- Click on the pop-up menu for the standard views.
- Choose **Top/Plan**.

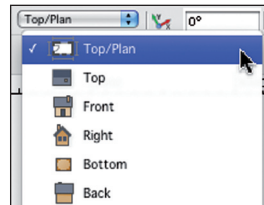

- Select the first (left-hand) rectangle.
- Go to the Menu Bar.
- Choose **Model > Extrude...**

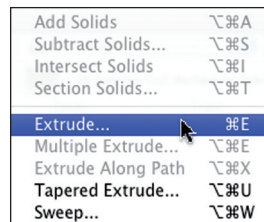

- Extrude this rectangle **2000mm (6')**. This rectangle has been extruded towards you, that is, it has been extruded up.

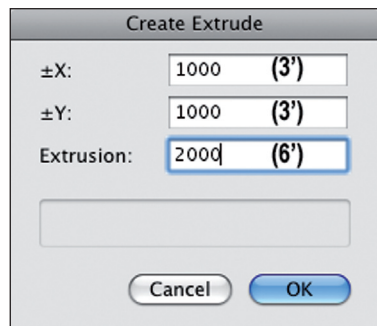

- Select the second (middle) rectangle.
- Go to the View Bar.
- Click on the pop-up menu for the standard views.
- Choose **Front**.

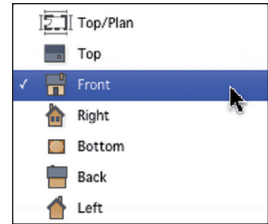

In this view you can see how the first rectangle was extruded up in 3D.

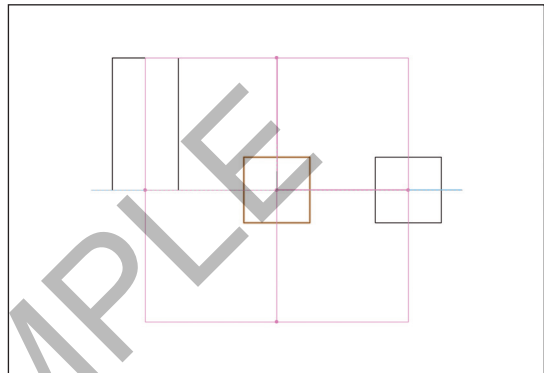

- Go to the Menu Bar.
- Choose **Model > Extrude...**
- Extrude this rectangle **2000mm (6')**. This rectangle has been extruded toward you—in the front view.

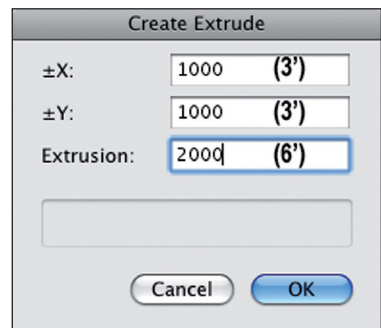

- Select the last rectangle.
- Go to the View Bar.
- Click on the pop-up menu for the standard views.
- Choose **Right Isometric**.

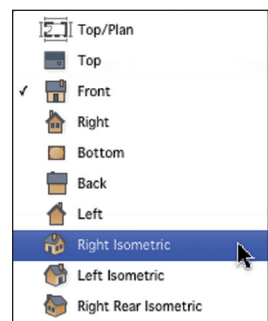

- In this view you can see how the first rectangle was extruded up in 3D and the second rectangle was extruded towards the front.

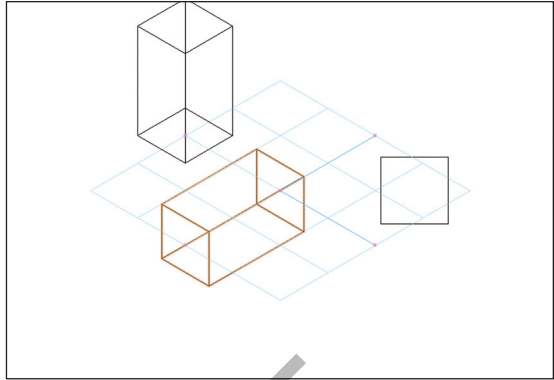

- Go to the **Menu Bar**.
- Choose **Model > Extrude...**
- Extrude this rectangle **2000mm (6')**. This rectangle has been extruded toward you—in the isometric view.

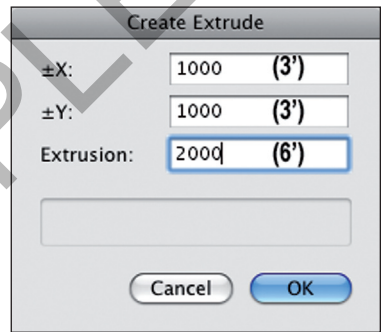

- Try out the **Top/Plan** view, and you will see how the three rectangles have been extruded in different directions.

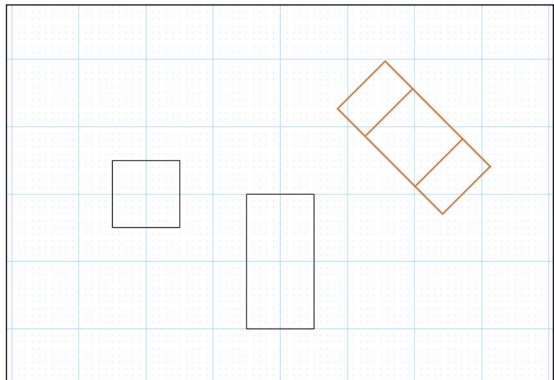

Editing Extrusions

Vectorworks allows you to edit extrusions after they are made. This means you can make a quick extrusion and then go and edit it when you have more time.



- Open the file **3D Model 2.sta** from the exercises folder.
- Double click on the extrusion. Vectorworks will take you into an extrusion edit mode so that the original 2D shape can be edited.
- Remember that if you want to edit most objects in Vectorworks, double click on it (not all objects are edited by double clicking on them).

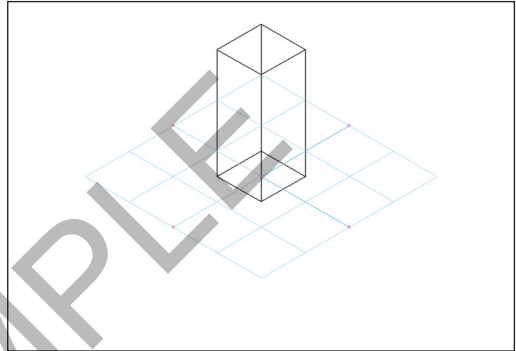

- This displays the 2D shape used to create the extrusion.

Notice the large orange button at the top right and the orange border around the drawing window. These show you that you are inside the editing area of the extrusion.

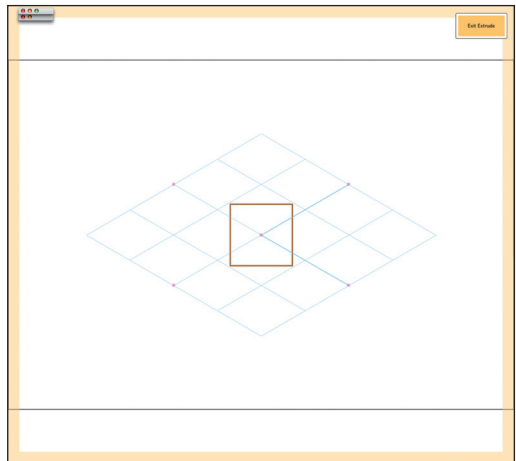

- Add a circle to the 2D shape as shown.

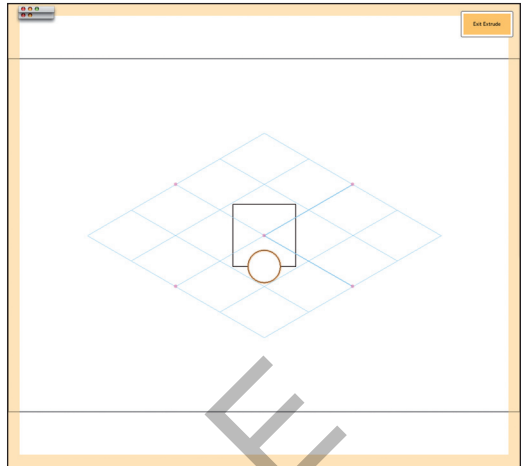

- Click on the **Exit Extrude** button on the top right of the drawing area.

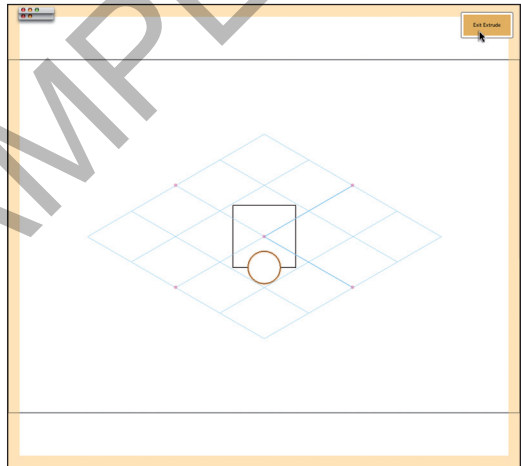

- You can see the results in 3D.

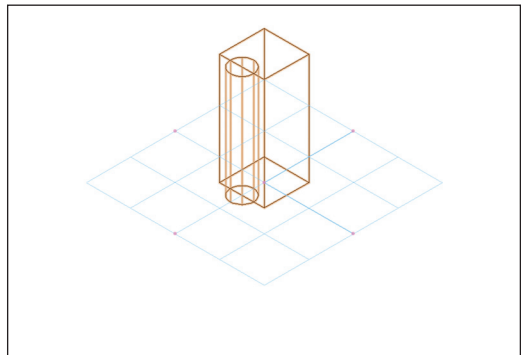

You can select several objects at the same time and extrude them. They don't become a multiple extrude. Rather, they become a single extrude or a group of extruded objects. Edit Extrude will still display all the 2D shapes used to create the extrusion, and Ungroup will leave them as individual extrusions.

1.2 Multiple Extrude

A Multiple Extrude is quite different from the standard extrusion. If you select two shapes and choose extrude, you end up with the two shapes extruded, which looks like a group of extruded objects. A Multiple Extrude is used to create 3D forms that change shape from one end to the other, or change shapes in the middle. You can use two shapes to create a simple 3D shape that changes shape from one end to the other, or you can use several shapes and make a sort of “skinned” object.

There are some rules for using and creating Multiple Extrusions:

1. Extrusions are always based on the viewing plane. They seem to come out of the screen at you. If you are in Top/Plan or Top, the extrusion will be in the Z direction only. If you are in a front view, the extrusion will be in the Y direction only.
2. Multiple Extrusions always start at 0 on the current working plane. If you haven't set a working plane then the extrusion will start at Z=0 on the current layer.
3. The Multiple Extrusion is based on the 2D shapes used to create it, and these 2D shapes are stored by Vectorworks and can be edited. You can use the command Edit Multiple Extrude from the Modify Menu to edit the 2D shapes to change the Multiple Extrusion.
4. The stacking order of the objects (front to back) determines the shape of the Multiple Extrude. The object that is at the back (or drawn first) is at the bottom of the extruded object. The object that is at the front (or drawn last) is at the top. The stacking order can be changed at any time by using the Send to Back or Send to Front commands in the Modify Menu.
5. You can edit the length of the extruded shape using the Object Info Palette.
6. You can edit the 3D location of the extruded shape using the Object Info Palette.

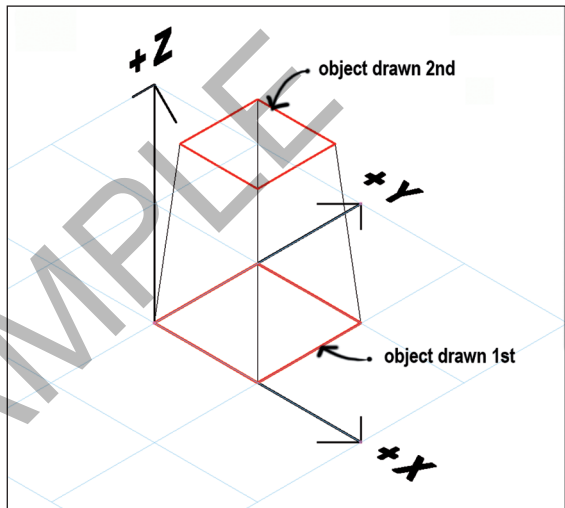

- Open the file **3D Model 3.sta** from the exercises folder.



We are going to draw a chimney shape, a shape that changes from the base to the top. We need to draw both the bottom shape and the top shape.

Tip: The easiest way to create a rectangle of a specific size and position is to double click on the Rectangle Tool. This opens a dialog box for you to type in the size and position of the rectangle that you want to create.

- Using the Rectangle Tool create a **1000x750mm (40x30 in.)** rectangle with the insertion point in the middle of the rectangle and the coordinates at **0,0**.
- Click on the **OK** button.

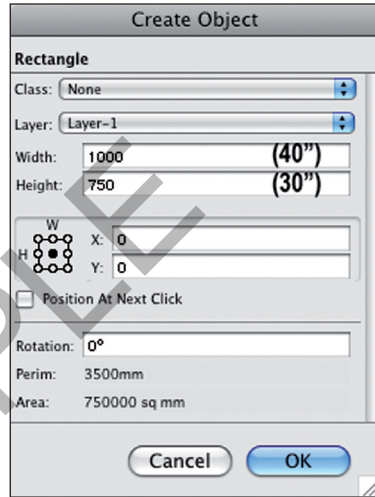

- Then draw a **750x500mm (30x20 in.)** rectangle on top of the first rectangle so that their centers line up, that is, they are aligned center/center.
- Click on the **OK** button.

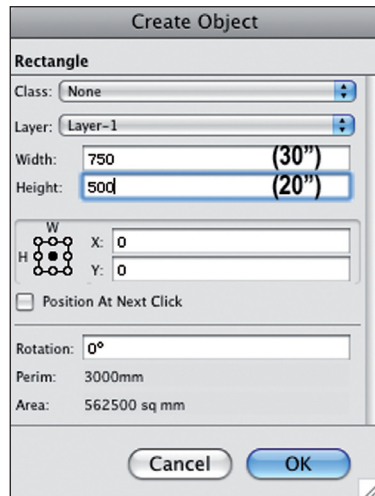

- Make sure that you are in **Top/Plan** view.

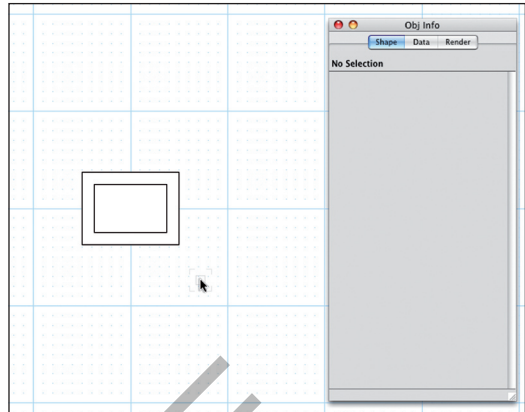

- Select both rectangles.
- Go to the Menu Bar.
- Choose **Model > Multiple Extrude...**

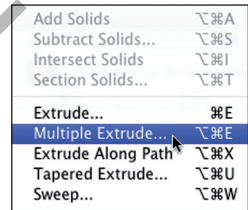

- Enter the extrude height as **3500mm (11'8")**. This will create a slender tapered extrusion. As with all extrusions, this object starts at 0 on the working plane and comes out of the screen at you.
- Click on the **OK** button.

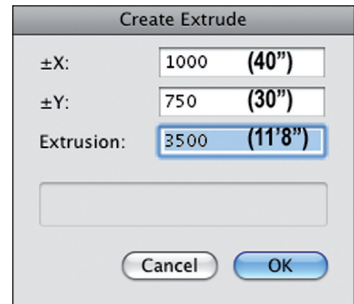

- In Top/Plan the object looks different.

A chimney has just been created so it will still be selected. If the Object Info Palette is not open, go to Palettes on the Menu Bar and choose Object Info. The Object Info Palette allows you to make changes to the size of the extrusion, ΔX , ΔY , and the extrusion length.

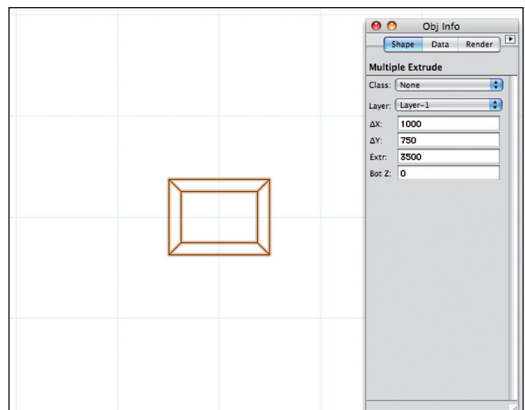

We want to change the height of the chimney. But we also want to see what the chimney looks like in 3D.

- Go to the View Bar.
- Click on the pop-up menu for the standard views.
- Choose **Right Isometric**.
- You can see your chimney in 3D.

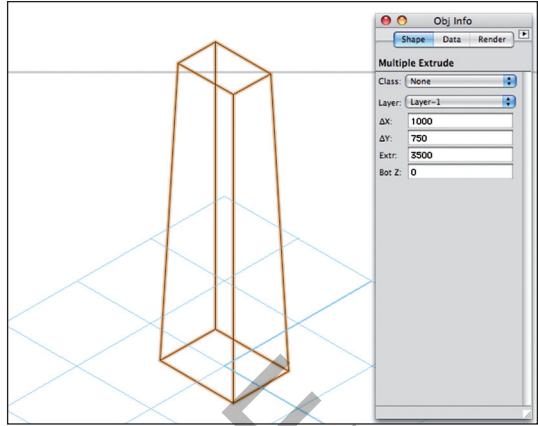

- The chimney should still be selected, so go to the Object Info Palette and change the extrusion height to **1500mm (60 in.)**.

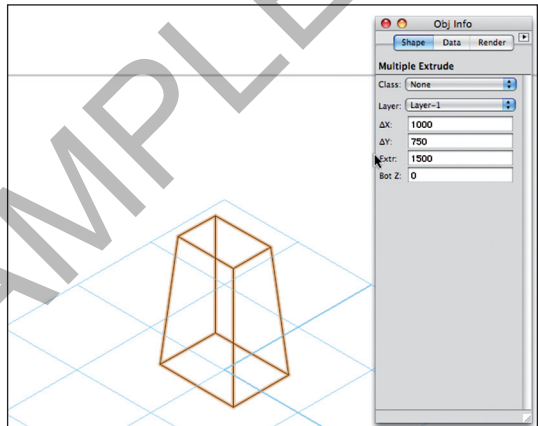

- Double click on the edge of the object.

Although you are in a 3D view, you are looking at the two 2D shapes used to make the chimney.

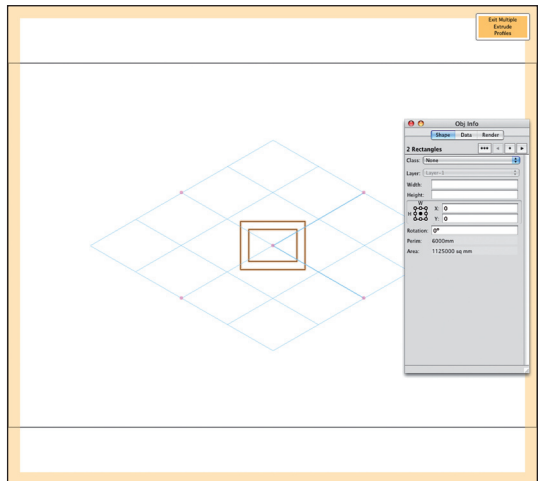

- Deselect everything by clicking away from everything with the 2D Selection Tool, or tap the 'X' on your keyboard twice.
- Right mouse click on the top rectangle (on a one button mouse, use control-click).
- Choose the option **Send > Send to Back**.

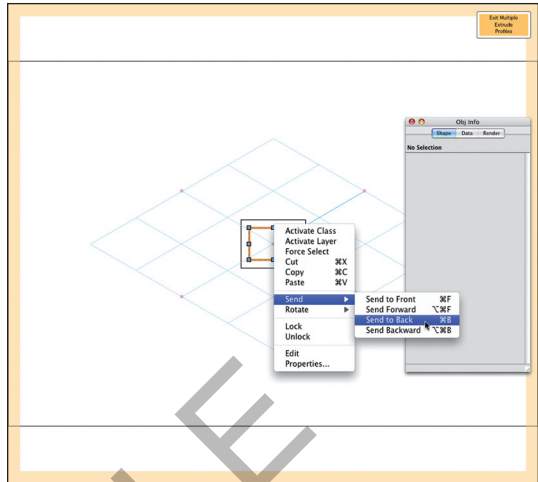

- Click on the **Exit Multiple Extrude Profiles** button on the right side of the Tool Bar to see the results in 3D. As I noted earlier, Vectorworks uses the stacking order (the front-to-back order) of the objects to work out which rectangle to put at the bottom and which one to put at the top.

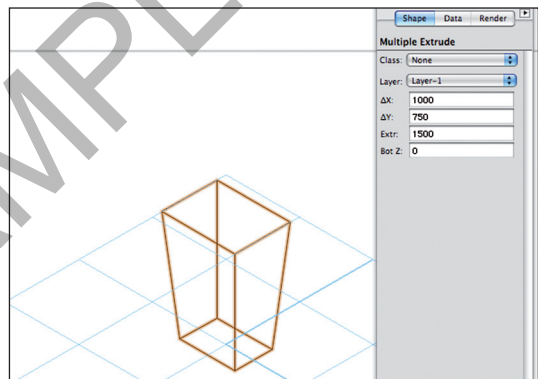

- Double click on the edge of the object.
- Right mouse click on the bigger rectangle and choose **Send > Send to Back**.

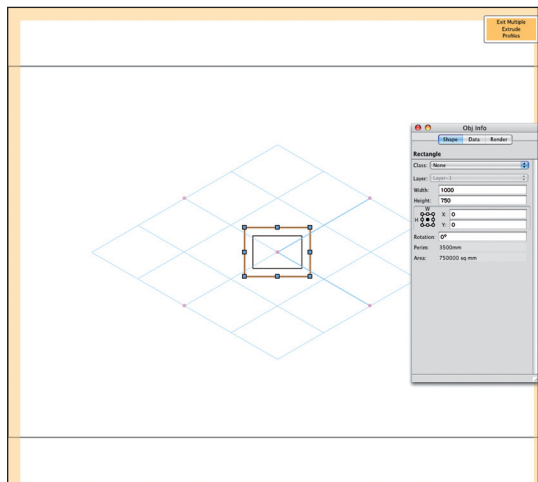

- Select both rectangles.
- Go to the Menu Bar.
- Choose **Modify > Align > Align/Distribute...**
- Align the rectangles so that the center/tops are aligned.
- Click on the **OK** button.
- Click on the **Exit Multiple Extrude Profiles** button on the right side of the Tool Bar.

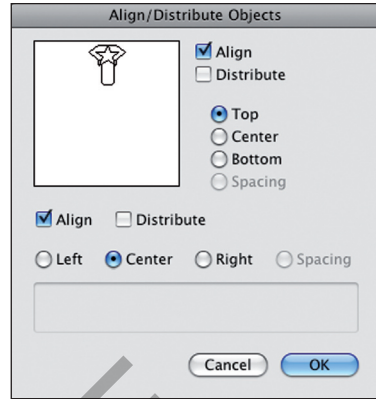

- You can see the results in 3D.

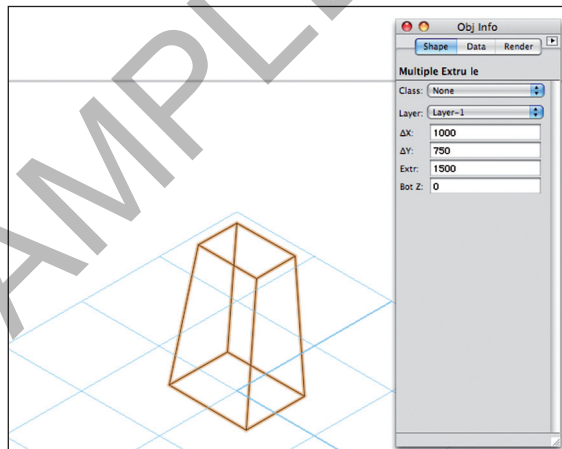

1.3 Simple Cafe Table

One of the important tricks with 3D modeling is learning to break your 3D model into manageable chunks. To demonstrate what I mean, we will be creating this table.

To make this table in one 3D object would be hard. However, you might notice that you could make this table from two multiple extrudes for the center leg with a simple extrusion for the top.

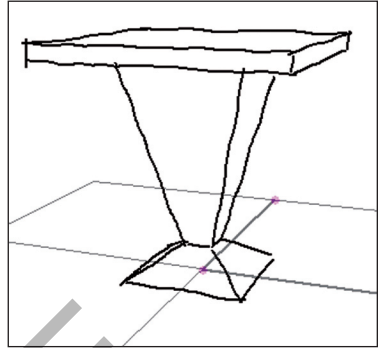

- Open the file **3D Model 4.sta** from the exercises folder.
- We will start by creating the base of the table.
- Use the create rectangle dialog box (by double clicking on the Rectangle Tool) to create two squares at 0,0.
- The first square should be **400x400mm (16x16 in.)** with the insertion point at the center of the rectangle and the coordinates at **0,0**.
- The second rectangle should be **100x100mm (4x4 in.)** with the insertion point at the center of the rectangle and the coordinates at **0,0**.

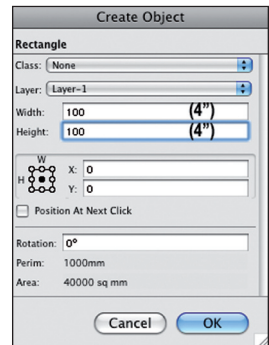
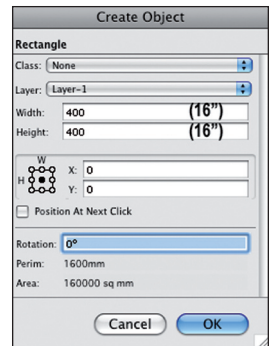

- Select both of these rectangles.

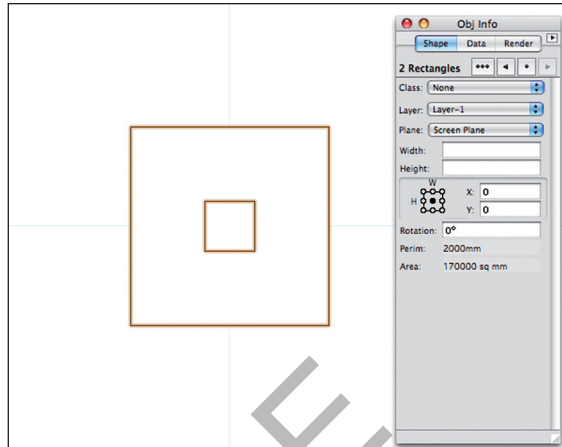

- Go to the Menu Bar.
- Choose **Model > Multiple Extrude...**
- Leave the X and Y dimensions, and in the Extrusion field put in a height of **100mm (4 in.)**.

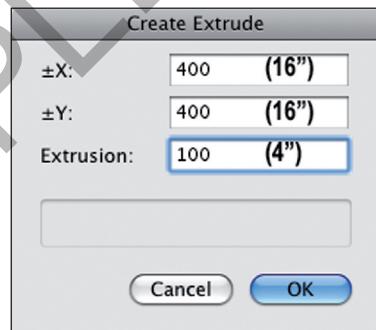

This creates the base portion of the leg for us.

- Create two more squares at **0,0** using the same method that we used for the base portion.
- The first square should be **100x100mm (4x4 in.)** with the insertion point at the center of the rectangle and the coordinates at **0,0**.
- The second rectangle should be **400x400mm (16x16 in.)** with the insertion point at the center of the rectangle and the coordinates at **0,0**.

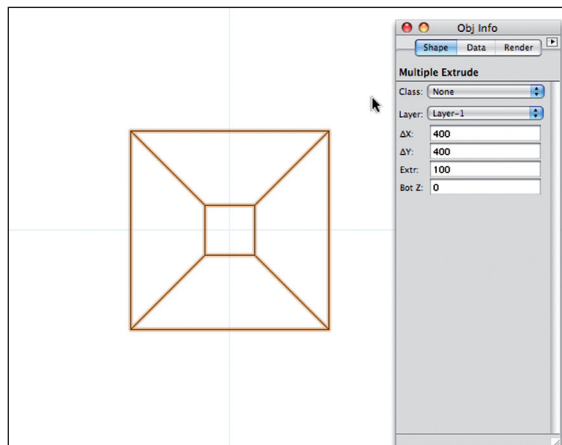

- Select only the last two squares. When you want to select more than one object, remember the multiple selection exercises that are covered in the quickstart guide to Vectorworks.

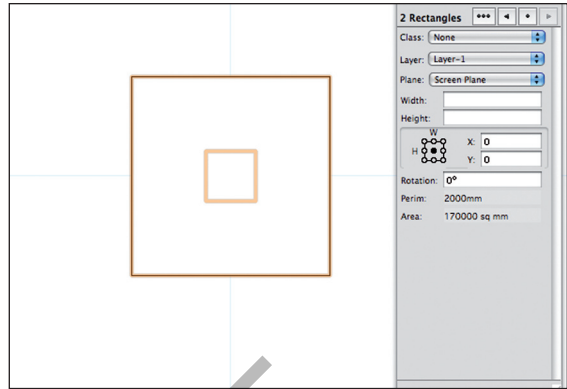

- Go to the Menu Bar.
- Choose **Model > Multiple Extrude...**
- Leave the X and Y dimensions and in the Extrusion box enter an extrude height of **600mm (24" in.)**.

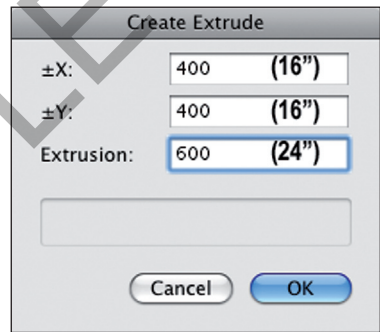

This multiple extrude is still positioned at 0 in the Z direction, so it needs to be moved up in 3D.

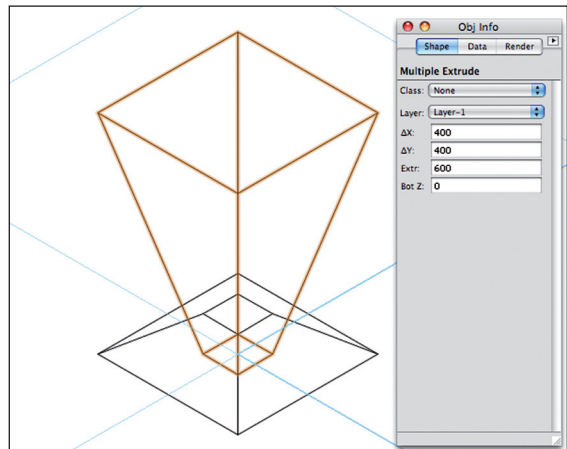

- Go to the Menu Bar.
- Choose **Modify > Move > Move 3D...**



- Move in the Z direction by **100mm (4 in.)**.
- Click on the **OK** button.

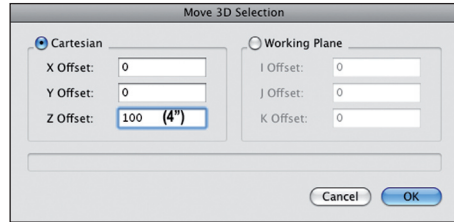

The middle part of the leg is now sitting on top of the base.

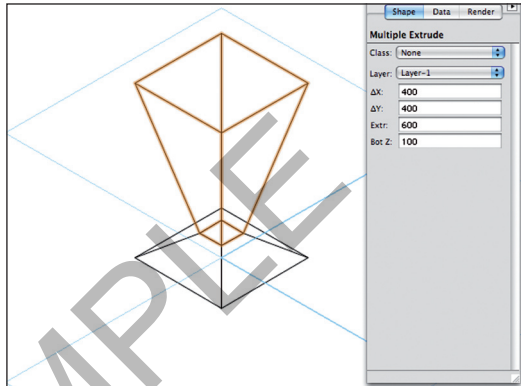

Now, for the top of the table:

- Change back to **Top/Plan** view.
- Create another **750x750mm (30x30 in.)** rectangle with the insertion point at the center of the rectangle and the coordinates at **0,0**.

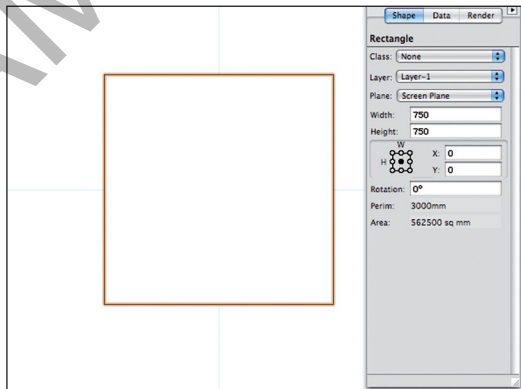

- Go to the Menu Bar.
- Choose **Model > Extrude...**
- Extrude the table top by **50mm (2 in.)**.

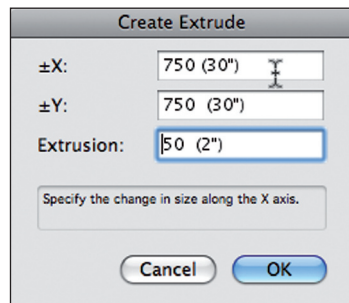

By default Vectorworks creates the extrusions on the ground, so, the table top has to be lifted up in 3D.

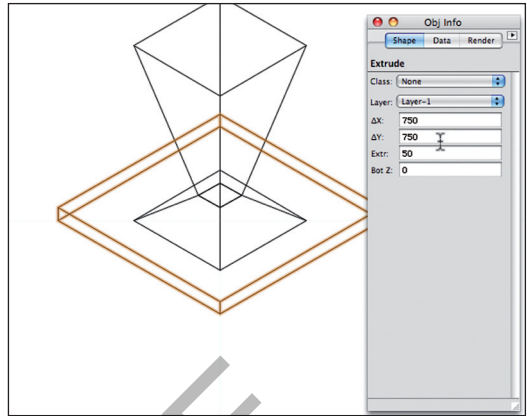

- Go to the **Menu Bar**.
- Choose **Modify > Move > Move 3D...**
- Move the table top up in the Z direction **700mm (28 in.)**.

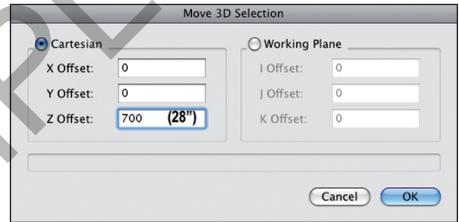

- Now the top is sitting on the leg in the correct place.
- We should change views to the 3D model.

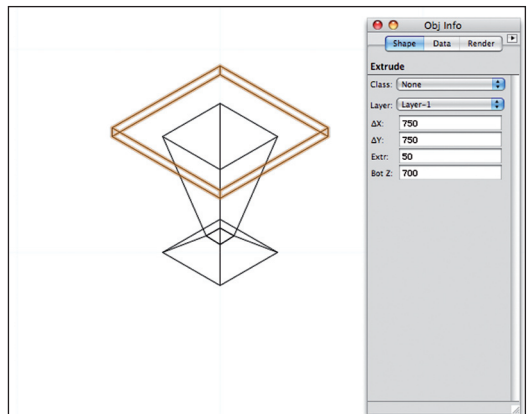

This method of building up the model around the center of the drawing is the best way to create furniture and 3D models. It allows you to position objects in 3D space about a known point, so you can use actual distances to place things.

SAMPLE