

Getting Started with
Vectorworks® Landmark



Table of Contents

Introduction	2
Section 1: Program Installation and Setup.....	5
Installing the Vectorworks Landmark Program	5
Exercise 1: Launching the Program and Opening the Starting File.....	6
Exercise 2: Adjusting Preference Settings.....	8
Section 2: Creating the Base Plan	11
Exercise 3: Importing a Site Plan PDF File.....	12
Exercise 4: Drawing the Property Line	16
Exercise 5: Drawing the Site House	20
Exercise 6: Drawing the Adjacent House	30
Exercise 7: Drawing the Paved Areas	32
Exercise 8: Drawing Existing Vegetation	40
Section 3: Laying out Constructed Elements	43
Exercise 9: Drawing the Privacy Fence	44
Exercise 10: Drawing the Pool.....	50
Exercise 11: Drawing Seat Walls.....	58
Exercise 12: Inserting Symbols	61
Section 4: Setting up Landscape Areas	66
Exercise 13: Drawing Hardscapes.....	67
Exercise 14: Drawing Planting Areas	73
Section 5: Creating the Planting Plan.....	78
Exercise 15: Placing Plants	79
Exercise 16: Introduction to the Plant Database.....	84
Exercise 17: Placing Trees	87
Section 6: Evaluating the Design	90
Exercise 18: Evaluating the Current Design	91
Section 7: Editing Landscaping Elements	94
Exercise 19: Moving and Reshaping Landscape Objects	95
Exercise 20: Modifying Multiple Plant Objects.....	99
Section 8: Creating Landscape Documentation	103
Exercise 21: Optimizing the Landscape Plan Drawing	104
Exercise 22: Creating Annotations	107
Exercise 23: Working with Plant Schedules	110

Introduction

Welcome to Vectorworks Landmark! This tutorial will introduce you to key tools and techniques for drawing and editing, and a streamlined workflow which provides the proper framework for exploring the full power of Vectorworks Landmark on your own.

Note: Renderworks must be installed for proper operation of all exercises with rendering commands.

Important: For free tutorial updates, completed exercise files, checking files, and instructional videos, visit the [Landmark Getting Started](#) website.

Overview of the Design Process

In this thematic tutorial, you use Vectorworks Landmark to design landscaping for a half-acre residential site. You begin with a pre-configured (but otherwise blank) starting file, and continue using this *single file* for all design phases and documents. You complete the project by creating a basic landscaping plan document:

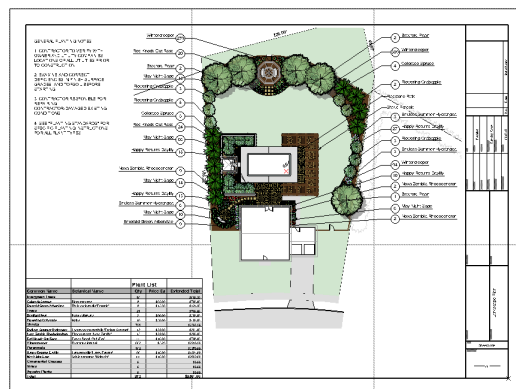
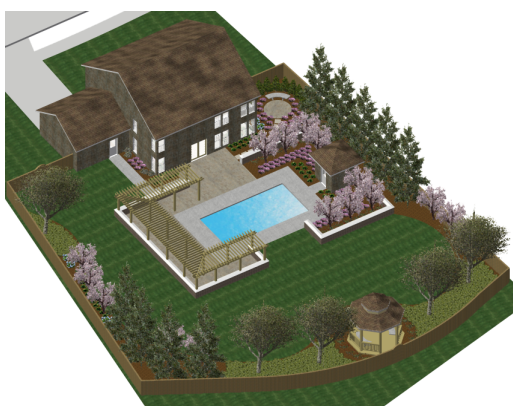

As you work through 23 continuing exercises, you develop the residential landscape design using a combination of Vectorworks standard and Vectorworks Landmark tools to complete the following design processes in order:

- Program setup
- *Creating the base plan
- Laying out constructed elements
- Setting up landscape areas
- Creating the planting plan
- Evaluating the design
- Editing landscaping elements
- Creating landscape documentation

*You can optionally skip this section (and review it later) if you can't wait to explore Landmark's landscaping design tools.

Notes:

- 1) You start with a pre-configured template file (that you can modify for use in your own projects) to skip repetitive setup processes, and ensure proper operation of exercises.
- 2) Starting with [Exercise 3](#), you can optionally open completed exercise files (available from the [Landmark Getting Started](#) website) to check your model or to skip ahead to the beginning of the next exercise. For example, open the **GS-VWLx10.vwx** file (completed Exercise 10) to start at the beginning of Exercise 11 (see the [General Exercise Tips](#) section for more information).
- 3) Although other landscaping documentation is already set up in the template file, this tutorial focuses on creating landscape plan documentation for a residential landscaping design project.

How to Use This Tutorial

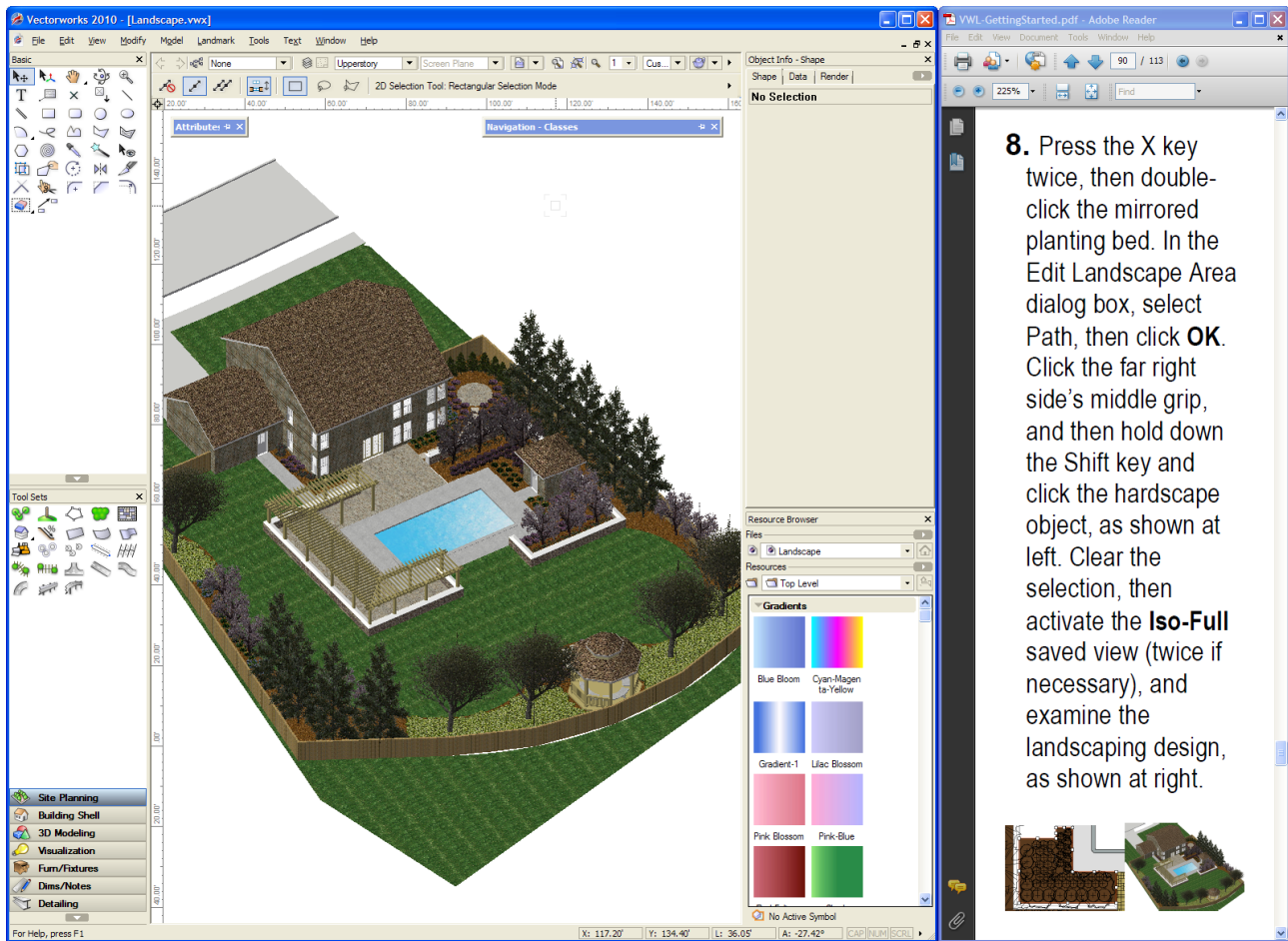

This tutorial is provided as an e-Book, in PDF format. You can print any or all pages for reference, or you can view the tutorial on-screen for enhanced electronic benefits including navigation links and search features.

If you choose to view the tutorial on-screen, you can optionally enable **Reflow** viewing mode (available from the View menu only in the Adobe Reader 7 or Adobe Acrobat 7 programs, available from the **View > Zoom** menu in newer versions) to display the text with a wrapping effect similar to a web browser. You can then adjust the Zoom level, and resize both the tutorial and Vectorworks windows to display them side-by-side as shown.



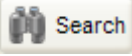

8. Press the X key twice, then double-click the mirrored planting bed. In the Edit Landscape Area dialog box, select Path, then click **OK**. Click the far right side's middle grip, and then hold down the Shift key and click the hardscape object, as shown at left. Clear the selection, then activate the **Iso-Full** saved view (twice if necessary), and examine the landscaping design, as shown at right.

Notes:

- 1) You can review workflow sequencing and locate specific procedures by scanning the process lists at the start of each section. The process lists are also hyperlinked to facilitate navigation.
- 2) If you view the tutorial on-screen, look for the **Previous View**  and **Next View**  tools at the bottom of the screen (or available in the Page Navigation toolbar in newer versions). These useful tools—available in Adobe Reader and Acrobat—let you revert or repeat navigational changes by page controls, bookmarks, and hyperlinks.
- 3) If you use **Reflow** viewing mode with the Adobe Reader window configured as shown in the figure above, you may need to temporarily increase the size of the window to see details in larger figures.
- 4) The Adobe Reader **Search**  provides more extensive options for searching text than the **Find** command.

General Exercise Tips

Use the following tips to facilitate working with your exercise drawing files:

- Read each step *carefully* and make sure your results match the figures. If your results vary from the figures, stop immediately and review the previous steps. If you can't find the problem quickly, start the exercise over with the appropriate supplied file.
- Alternate methods are shown for activating many tools, commands, and modes. Use the method that works best for you.
- In many cases, you must click in the drawing area after using the Navigation palette before continuing with the next step.
- Watch for SmartCursor cues that appear when you hover your cursor over significant drawing object geometry. Pause briefly over snap points to display the red snap box, and watch for the red confirmation dot displayed temporarily after you complete the snap. When too many red snap boxes are displayed in congested areas, press the Esc key once to clear the display.
- For some operations, additional view adjustments may be required. For these cases, press the Z key for the **Snap Loupe** shortcut, or use the **Zoom**, **Pan**, and **Fit to Objects** tools as required. If you have a mouse wheel, use it to zoom in and out.
- To pan across the drawing at any time (even if a tool or command is active) hold down the Space Bar and drag the cursor.
- If you inadvertently cleared a selection required for an active tool or command, press Space Bar+X temporarily, and then select the object(s).
- Many tools have different operational modes, which you can select in the Tool bar (located above the drawing window).
- Keep the Object Info palette open (to open it, select **Window > Palettes > Object Info**). It displays valuable information, and provides access to key properties of selected objects.
- Press the Esc key to cancel any operation. If you are using a tool, it will still be active, but you can then start drawing again or choose another tool. Sometimes, you must press the Esc key before you use a keyboard shortcut to activate another tool.
- Use the **Undo** command in the Edit menu to revert steps as necessary (both drawing *and* view changes are reverted).
- For tools that create multiple segments (such as the **Wall** tool) press the Delete key once while the tool is active to revert a single segment, or press it repeatedly to revert additional segments.
- If multiple files are open, you may need to click the Resource Browser's **Home** button  if your house file isn't active.
- Object artifacts may remain in the drawing area after some drawing and editing operations. To refresh the screen and clear the artifacts, double-click the **Pan** tool  (in the Basic tools palette).
- Save your files often to prevent data loss.

Important: Exercise steps in this tutorial are based on default preference settings from a new installation of the Landmark program with Renderworks. Results for some steps may vary from the figures if your preference settings differ from the defaults.

Using Metric Units with Exercises

All exercise data set files for this tutorial are set to use imperial units. If you want to use metric values for the exercise steps, enter the values exactly as shown in [square brackets, with the unit mark], and Vectorworks will convert the values accordingly. If you want to measure distances or drawing objects for reference, use the appropriate dimension tool and object snaps to create temporary dimensions, which are set by default to display alternate units in metric values. Delete the temporary dimensions when finished.

Note: For proper exercise operation—and to validate your results with the imperial figures—do not change the document's units setting to metric.

Keyboard Shortcuts

All keyboard shortcuts included in this guide are based on the Windows operating system. If you're using a Mac, use the Option key instead of the Alt key, and use the Cmd key instead of the Ctrl key. Refer to the Vectorworks 2010 Shortcuts PDF file (available from the Online Help) to print a complete list of your own keyboard shortcuts.

Section 1: Program Installation and Setup

In this section, you start by installing the Vectorworks Landmark program. Following installation, two exercises cover the following program setup and interface adjustment processes:

- Activating the Landmark workspace (pg 6)
- Opening the starting file (pg 7)
- Adjusting Vectorworks preferences (pg 8)
- Adjusting Grid and Smart Point settings (pg 9)
- Turning off the page boundary (pg 10)
- Setting the default font (pg 10)
- Adjusting the Navigation palette display (pg 10)

In these exercises, you activate (or reset) the Vectorworks Landmark interface, and then you adjust program preference settings and adjust the interface.

Installing the Vectorworks Landmark Program

Note: If you have already installed Vectorworks Landmark, start with step 2 below.

1. Follow the installation instructions in the **ReadMe** file located in the root folder of your installation DVD.
2. Start the program. You can do this by selecting **Programs > Vectorworks2010 > Vectorworks2010** from the Windows Start Menu.
3. From the menu, select **Help > Check for Updates**. If updating is necessary, follow the on-screen instructions.
4. After updating, close Vectorworks (if it's still running) to reset the program.

Exercise 1: Launching the Program and Opening the Starting File

In this exercise, you launch the application and activate the Vectorworks' Landmark workspace. After a brief orientation of the Landmark interface, you then open the supplied starting file.

Activating the Landmark workspace

You start the exercise by launching the Vectorworks program.

1. From the Windows Start Menu, select Programs > Vectorworks2010 > Vectorworks2010.
2. From the menu, select **Tools > Workspaces > Landmark**. If the Landmark workspace is already active, select it again to reset the interface. Position the Navigation palette where shown, and examine key areas of the interface identified in the following figure.

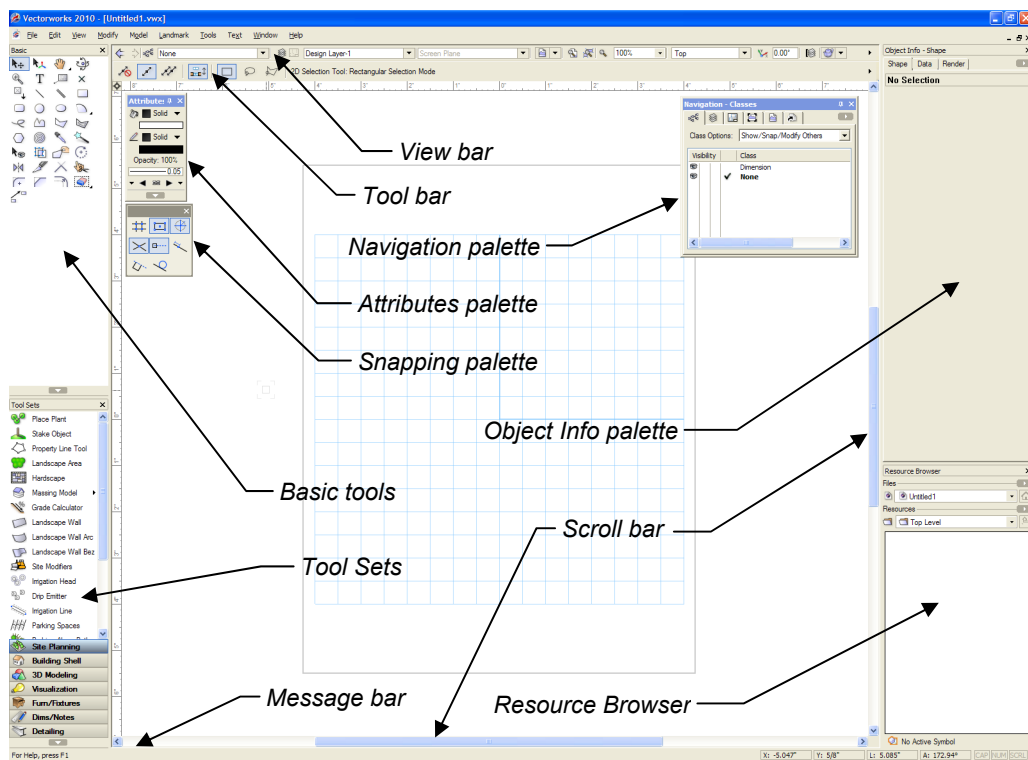

Opening the starting file

Next, you open the supplied starting file. To save time, this starting file contains many pre-configured resources, and is already fully set up for creating a residential landscape project.

3. Close any open files, and then from the menu, select **File > Open**. In the Open Vectorworks Drawing dialog box, open the Data Set folder and open the read-only **GS-VWLx01.vwx** file. The page boundary is displayed, and it's ready for importing the site plan.
4. From the menu, select **File > Save As**, and save the file under the name **Landscape.vwx**.

Notes:

- 1) Design layers are used in landscaping projects as spatial containers for creating drawing objects, and to control object stacking order (such as trees appearing on top of plant beds in the Top/Plan view).
- 2) Sheet layers provide a 2D-only page layout environment for printing.
- 3) Sheet layer viewports are individual 2D "live camera view" objects that reside on sheet layers, but display 2D and 3D drawing objects on design layers. When you modify drawing objects on a design layer, the viewport itself doesn't change, but it displays the changes in the design layers.
- 4) Classes are used to control display properties of drawing objects.
- 5) The starting file contains additional resources that are not required for this streamlined tutorial, but are useful in complex landscape design projects that use Landmark's advanced features. After you learn how the file structure works, you may find it helpful to modify the starting file for use in your own landscaping projects.

Important: As you start the tutorial, do not be concerned if you don't fully understand the file structure. As you progress through the exercises, you will see how the file structure works in context of a landscaping project.

Exercise 2: Adjusting Preference Settings

In this exercise, you verify and adjust program preferences.

Adjusting Vectorworks preferences

You start the exercise by verifying or adjusting key application preference settings to ensure proper exercise operation. You then turn on scroll bars to facilitate navigation, and then you increase the maximum number of undos so you can revert exercise steps if necessary.

1. From the menu, select **Tools > Options > Vectorworks Preferences**. In the Vectorworks Preferences dialog box, select the Edit tab, and then verify or adjust settings as shown (keep the dialog box open for the next three steps).

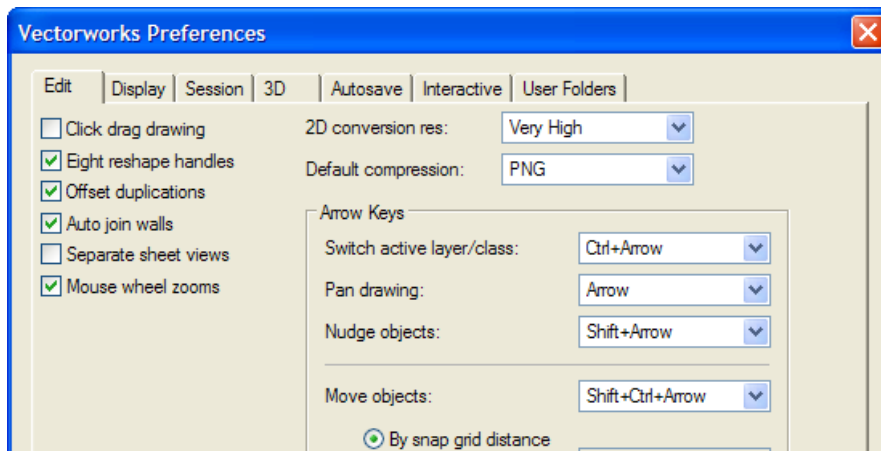

2. Select the Display tab, and enable the **Scroll bars** option, and then verify or adjust other settings as shown.

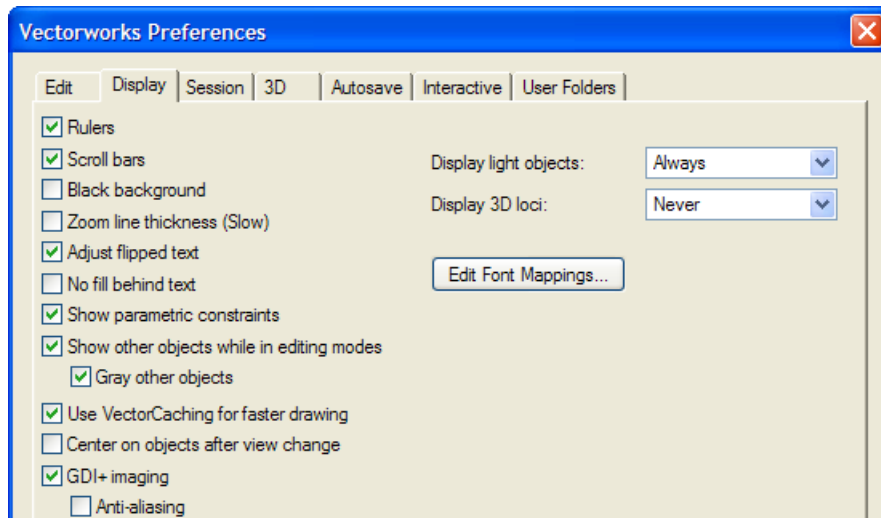

3. Select the Session tab, and then enter 100 in the **Maximum number of undos** field. Verify or adjust other settings as shown.

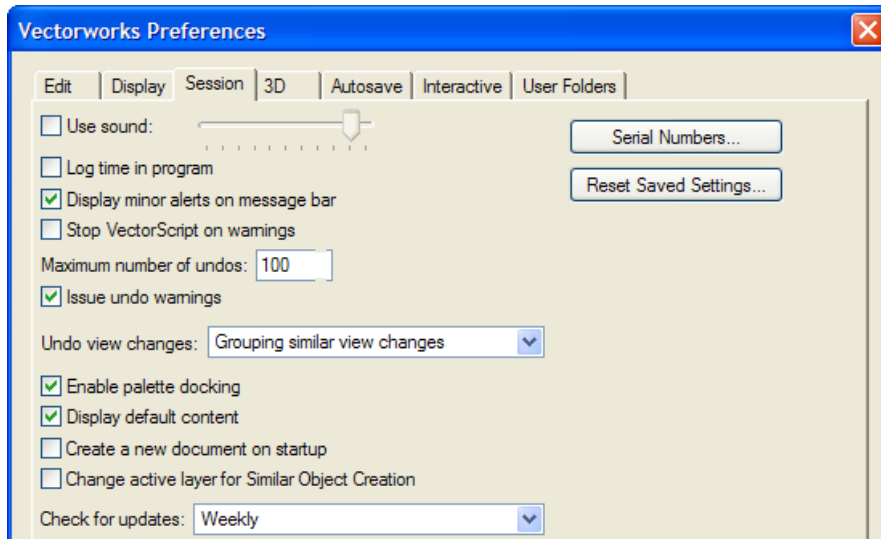

4. Select the Interactive tab, and then change the cursor's Selection box size, and Snap box size, and verify or adjust other settings as shown. Click **OK** to save the settings and close the dialog box.

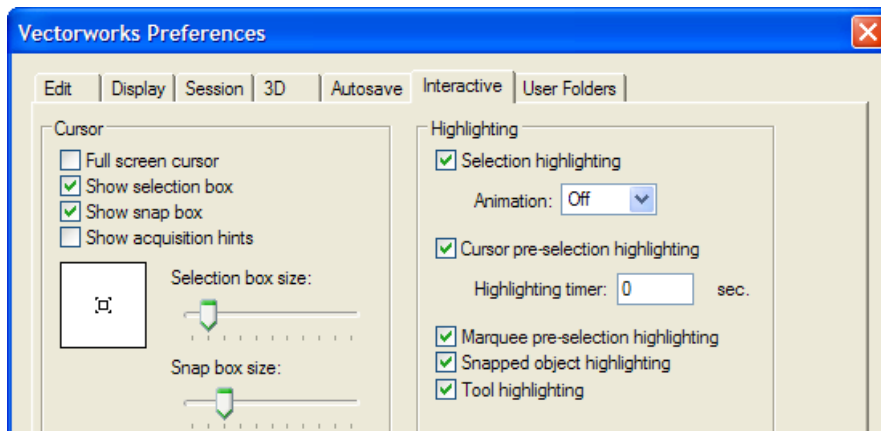

Adjusting Grid and Smart Point settings

5. Press Ctrl+8 to display SmartCursor Settings dialog box, and then select **Grid** from the Category list. Clear the **Show Grid Lines** and **Print Grid Lines** checkboxes, as shown at left. From the Category list, click **Smart Point**, and verify or adjust settings, as shown at right. Click **OK** to close the dialog box and save the changes.

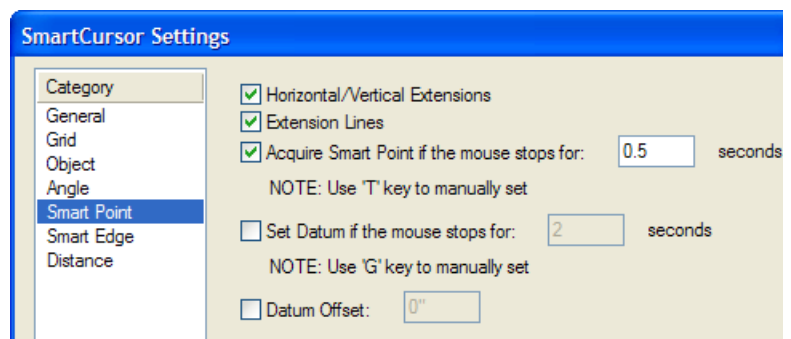
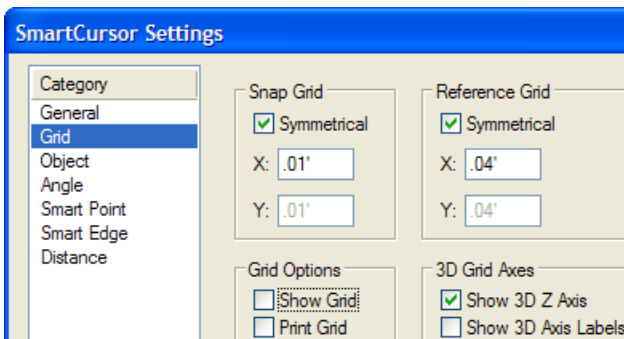

Turning off the page boundary

Next, you turn off the page boundary for clarity in the drawing area.

- From the menu, select **File > Page Setup**. In the Pages section of the Page Setup dialog box, clear the **Show page boundary** checkbox, as shown. Click **OK** to save the settings, and notice that the page boundary is no longer displayed in the drawing area.

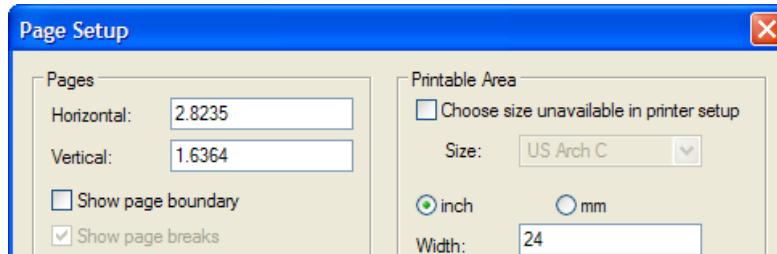

Setting the default font

Next, you adjust the default font.

- From the menu, select **Text > Font > Arial** to set the default font (if it's not set to **Arial** already), and then select **Text > Size > 12** to set the default font size to 12 point (if it's not set to **12** already).

Adjusting the Navigation palette display

- If your Navigation palette is not already displayed, from the menu, select **Window > Palettes > Navigation**. If necessary, expand the Navigation palette by dragging the lower right corner to resize it.

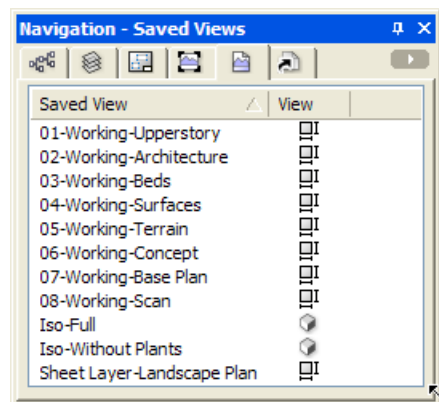

- In the Attributes and Navigation palettes, turn on **Auto Hide**  (**Window Shade** for Mac). If you're in a hurry to explore Landmark's landscaping design tools, skip [Section 2](#) (Creating the Base Plan) and continue with [Section 3](#).

Section 2: Creating the Base Plan

In six exercises, this section covers the following processes in the landscape design project:

- Importing the site plan by dragging and dropping (pg 12)
- Scaling the site plan (pg 13)
- Indexing the site plan with the drawing origin (pg 14)
- Tracing the property line (pg 16)
- Tracing the easements (pg 19)
- Saving a rotated view (pg 20)
- Drawing the house walls (pg 21)
- Drawing the house doors and windows (pg 23)
- Creating the house roof from walls (pg 25)
- Creating the garage roof from a rectangle (pg 27)
- Creating a massing model (pg 30)
- Drawing the driveway (pg 32)
- Drawing the front porch (pg 34)
- Drawing the sidewalks (pg 35)
- Drawing the straight road segment (pg 37)
- Drawing the curved road segment (pg 38)
- Drawing existing trees for removal (pg 40)
- Drawing existing trees to remain (pg 41)

In these exercises, you use a variety of tools on *design layers* to document existing site features, which are maintained throughout the landscaping design project.

Note: *If you're in a hurry to start the design process and explore Landmark's landscaping tools, you can skip this section and continue with [Section 3](#). If you skip Section 2 now, you should at least review it later. You will find it worthwhile because it covers best practices for documenting existing site conditions, in a workflow that returns the highest levels 2D and 3D benefits with minimal 2D input.*

Exercise 3: Importing a Site Plan PDF File

In this exercise, you import a PDF site plan that also serves as a site inventory mark-up. You then scale the imported PDF file, and move it into the desired location.

The completed exercise is shown in the following figure:

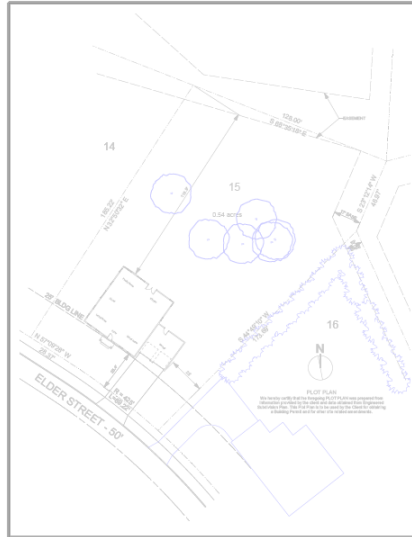

Importing the site plan by dragging and dropping

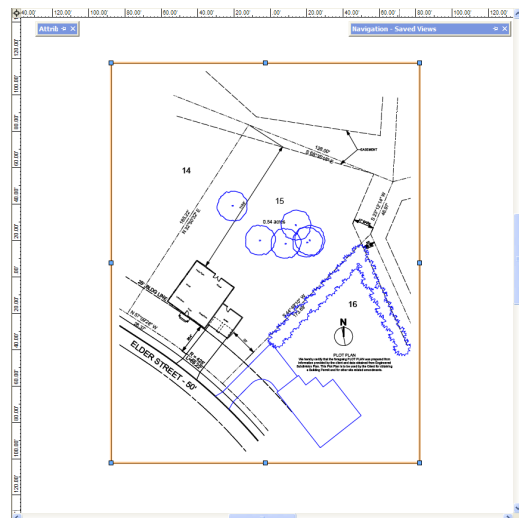
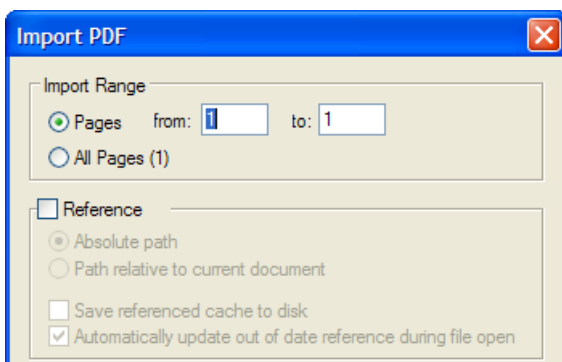

You start the exercise by opening the Data Set folder via your operating system, you then drag and drop the site plan file to import it in your drawing.

1. If you did not complete Exercise 2—or you are unsure of your file's accuracy—open the **GS-VWLx02.vwx** file.
2. Open the Data Set folder with Windows Explorer or Mac Finder. Drag and drop the **PlotPlan_InventoryMarkup.pdf** file in the approximate center of the drawing area. In the Import PDF dialog box, click Import to accept the defaults, as shown at left (leave the PDF page selected for the next five steps) and import the PDF page, as shown at right.



Scaling the site plan

Next, you scale the site plan to the full size by snapping to property line vertices.

- From the Basic tools palette, click the **Zoom** tool . In the Tool bar, enable **Marquee Zoom Mode**  (if it's not already active), and then draw a marquee from upper left to lower right as shown to zoom in.

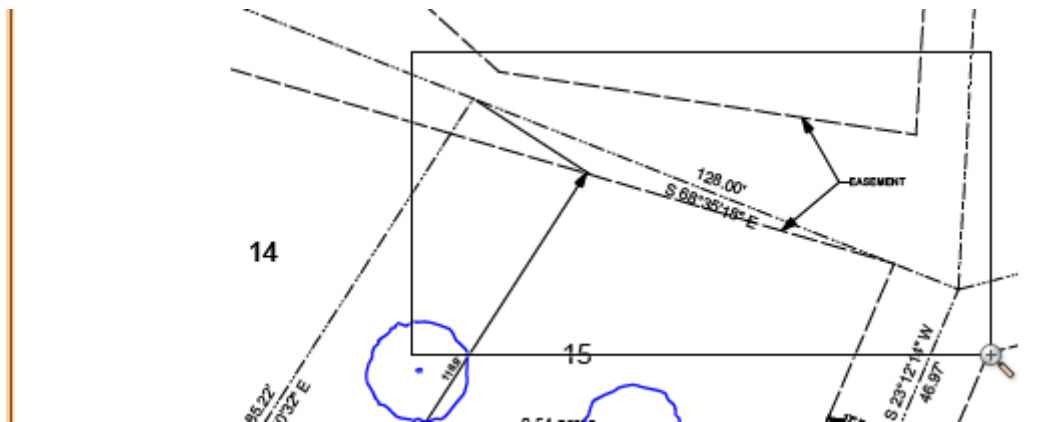

- From the menu, select **Modify > Scale Objects**: Enable the **Symmetric By Distance** option, and then click the Current Distance button  and snap to the vertices in order (when your cursor is over each vertex, press the Z key for the Snap Loupe shortcut to temporarily zoom in – see Tip below figure), as shown at left to specify the Current Distance. Enter 128' [39.014m] for the New Distance, as shown at right (see Notes below figure), and then click **OK** to scale the PDF page. Press Ctrl+6 for the Fit to Objects shortcut. The zoom is adjusted so that the resized PDF now fills the drawing area.

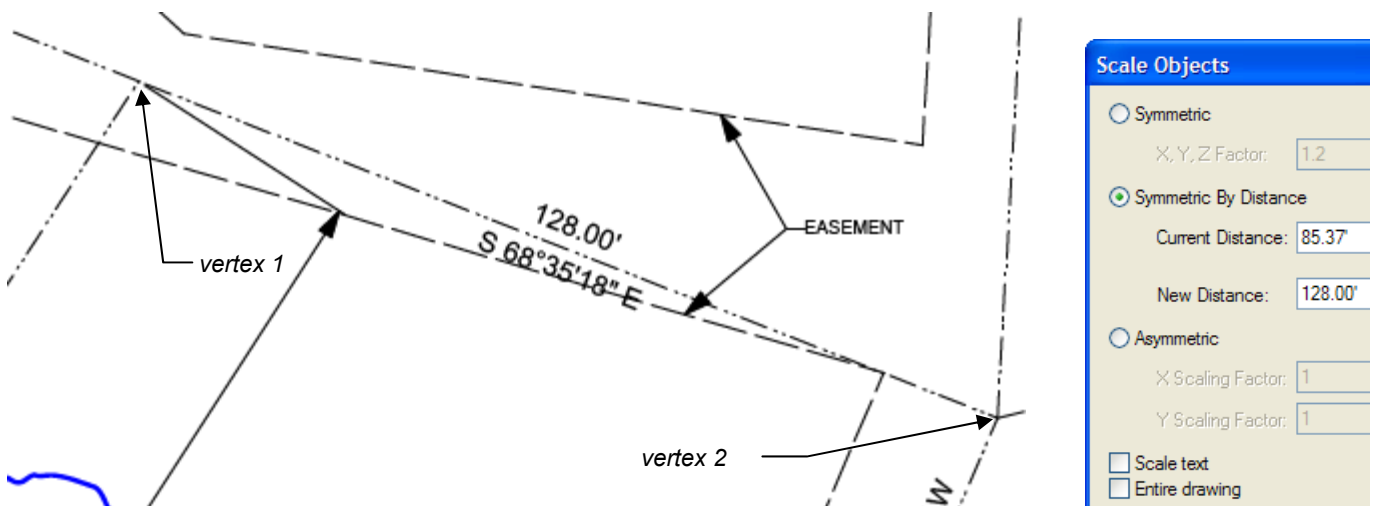



Tip: For best snap loupe performance, press Ctrl+8, select the **General** Category, and then disable the **Zoom Line Thickness in Snap Loupe** option.

Notes:

- 1) Verify that your **Current Distance** value is within 0.5' [152m] of the value shown above. If not, then repeat the snapping process and make sure you position your cursor over the correct vertex before you press the Z key to activate the snap loupe.
- 2) Make sure the **Scale text** and **Entire drawing** options are disabled.

Indexing the site plan with the drawing origin

Next, you use the **Move by Points** tool to reposition the PDF page by indexing one of the property line vertices with the drawing origin (0,0).

- Zoom in on the area shown at left. From the Basic tools palette, click the **Move by Points** tool . In the Tool bar, make sure **Move Mode**  is active. Snap to the lower left property vertex (SW corner shown at right, press the Z key and make sure you snap to the vertex), then move your cursor and press Tab five times to highlight the X value in the floating data bar. Enter 0 (zero) for the value, and then press tab and enter 0 (zero) for the Y value. Press Enter twice to move the PDF page, and then press Ctrl+6 to see the entire PDF page. The SW vertex is now aligned with the drawing origin (0,0).

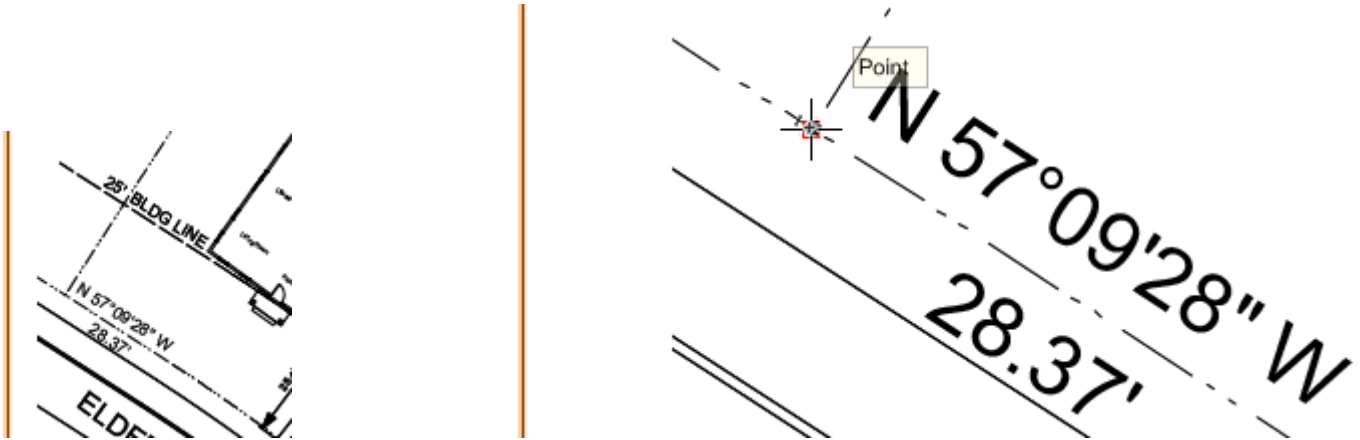

- In the Attributes palette, click **Opacity**, and set the slider to (or type in) 20% as shown at left, and then click **Set Opacity** to save the changes. The site plan now appears lighter, as shown at right.

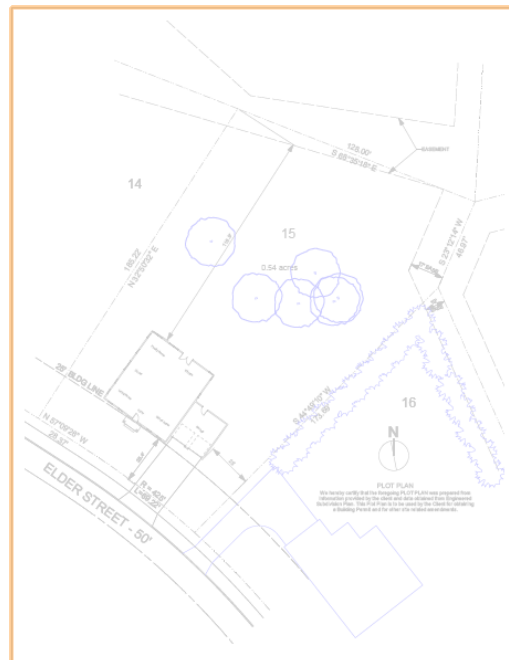
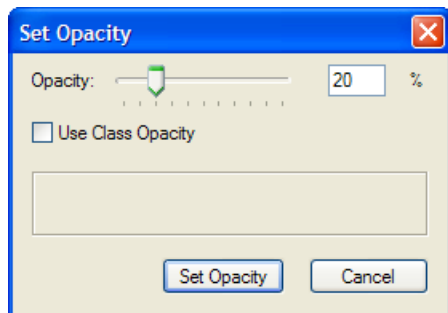

- From the menu, select **Modify > Lock**. The PDF page selection highlight turns gray to indicate it is locked, as shown at left. In the Object Info palette, select the Shape tab (if it's not already active), and notice that it also shows that the PDF page is locked, as shown at right.

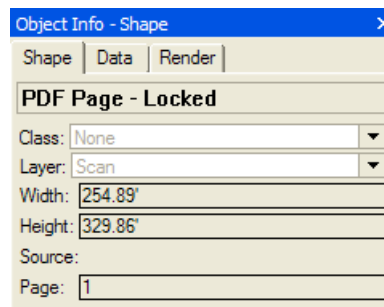
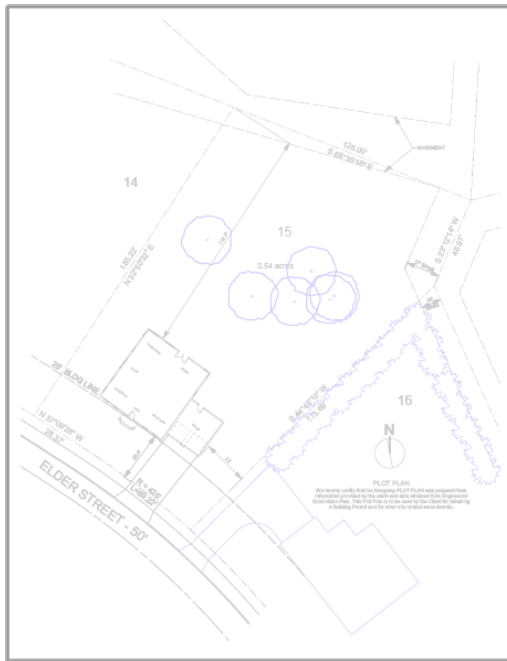

- Save the file.

Exercise 4: Drawing the Property Line

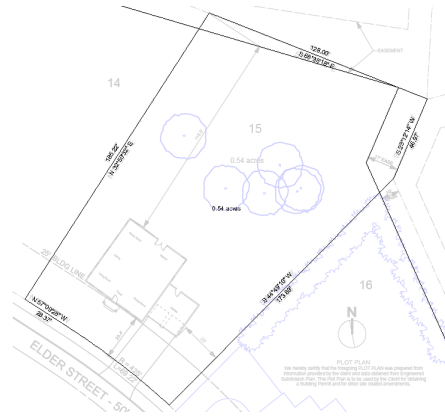

In this exercise, you trace the property and easement lines from the imported PDF file.

The completed exercise is shown in the following figure:



Tracing the property line

You start the exercise by drawing a polyline, traced from the PDF page. You then convert the polyline to a property line object.

1. To ensure proper operation of the remaining exercises, close your **Landscape.vwx** file (if it's open), and then rename it. Open the **GS-VWLx03.vwx** file. From the menu, select **File > Save As**, and then save the file under the name **Landscape.vwx**.
2. In the Navigation palette, select the Saved Views tab, and then double-click the **07-Working-Base Plan** view to activate it. In the View bar, notice that the Base Plan layer is now active. From the Basic tools palette, click the **Polyline** tool . In the Tool bar, enable **Corner Vertex Mode** , and then snap to the vertices shown at left (as highlighted locus points for clarity) in order. After snapping to vertex 6, enable **Point on Arc Mode** , then snap to any point on the arc between vertices 6 and 1, and then snap to vertex 1 to complete the polyline, as shown at right.

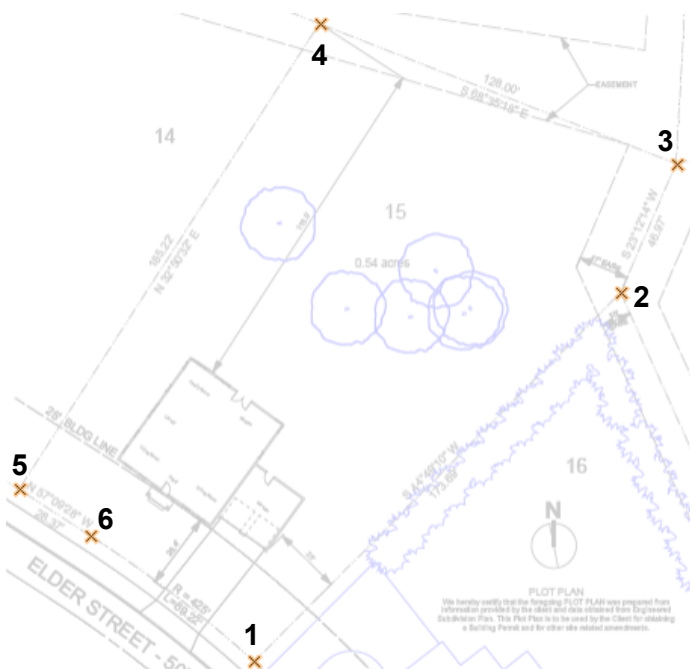

Note: You can snap to the PDF in this exercise because it was created from a vector-based source file. If you can't snap to a PDF in your own designs, or if you have to import a raster file, you can draw individual arcs, and then draw coincident lines by entering length and bearings in the floating data bar's L and A fields. You can convert the lines and arcs to a polyline or polygon with the **Compose** command, and then follow the steps below to convert it to a property line.

- From the menu, select **Modify > Convert > Objects from Polyline**. In the Create Objects from Polyline dialog box, adjust settings, as shown at left. Click **OK** to display the Object Properties dialog box, and then adjust settings, as shown at center. Click **OK** to create the property line, as shown at right.

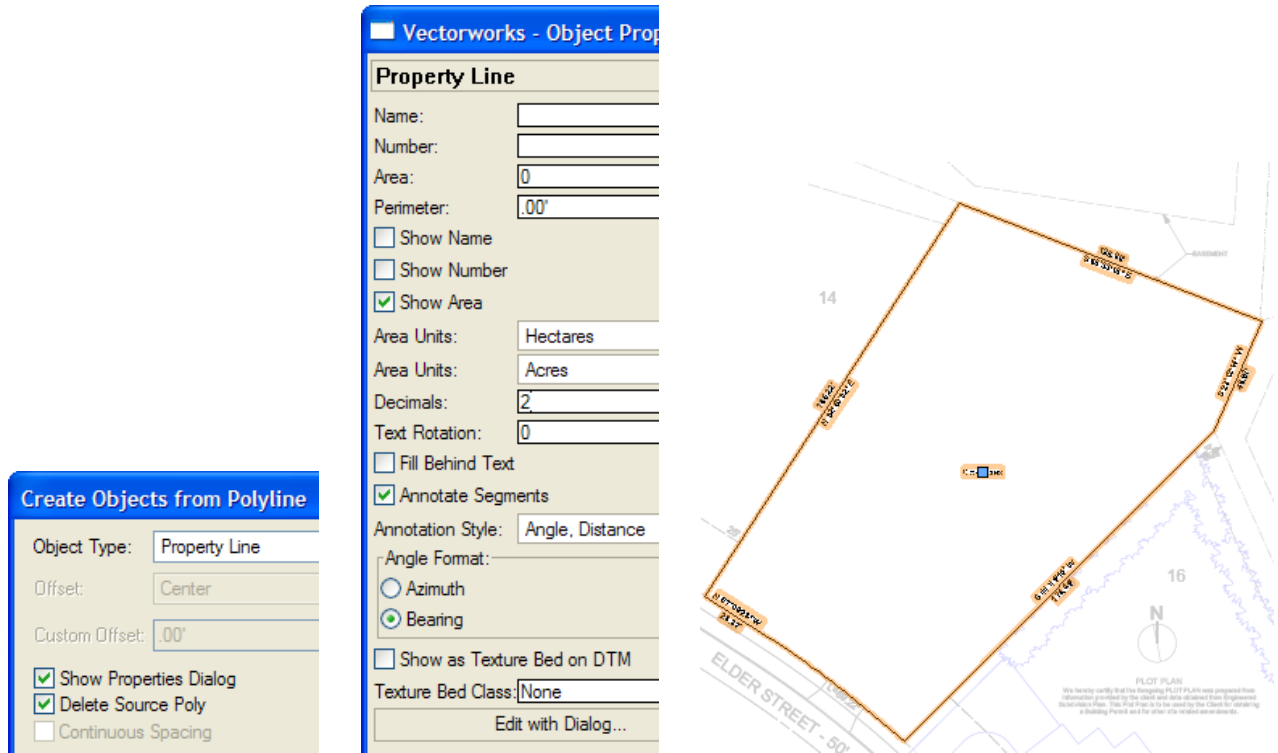

- In the Attributes palette, select **None** from the Fill Style drop-down list, as shown at left. You can now see through the property line, as shown at right.

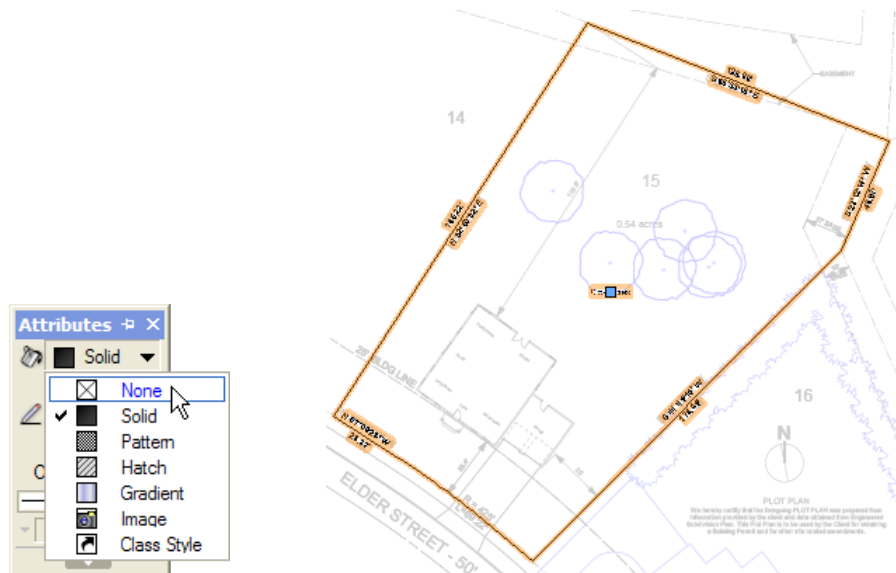

Next, you check property line segments and correct them as necessary. You can choose to optionally follow the next step, or to save time, you can close your file and open the **GS-VWLx04-Step06.vwx** file (with the property line segments already fixed) and skip ahead to step 6.

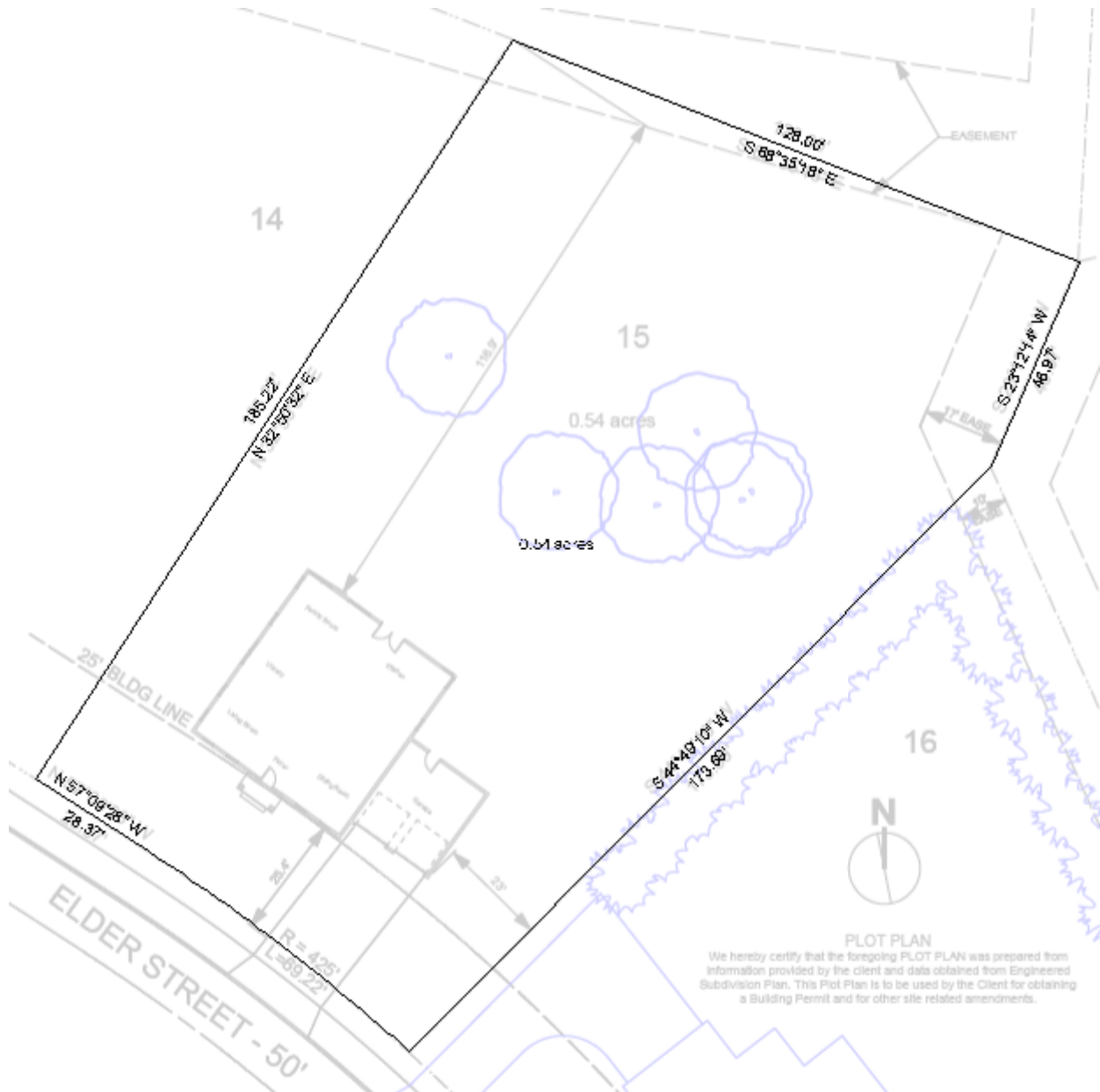

5. Zoom in and check all property line Bearing and Distance values against the light-gray PDF values (see Note below figure). If any segment doesn't match, double-click the property line object, and then click the **Next** button until the incorrect segment's values are activated. You can then edit the values (128.00' [39.014m], 185.22' [56.455m], 28.37' [8.647m], 173.69' [52.941m], 46.97' [14.316m]) to match the values of the imported site plan, and click **Update** to save the changes. Continue clicking **Next** as necessary to correct other segments. Click **OK** to save the changes, then press the X key twice to clear the selection, and examine the completed property line, as shown.



Note: To save time and avoid repetitive corrections, you can skip this step and open the **GS-VWLx04-Step06.vwx** file to start the next step.

Tracing the easements

Next, you use the **Line** tool to trace easement lines that lie inside the property line.

- From the Basic tools palette, click the **Line** tool . In the Tool bar, make sure **Unconstrained Line Mode**  is active, and then snap to consecutive endpoints to trace the three easement lines (highlighted for clarity), as shown.

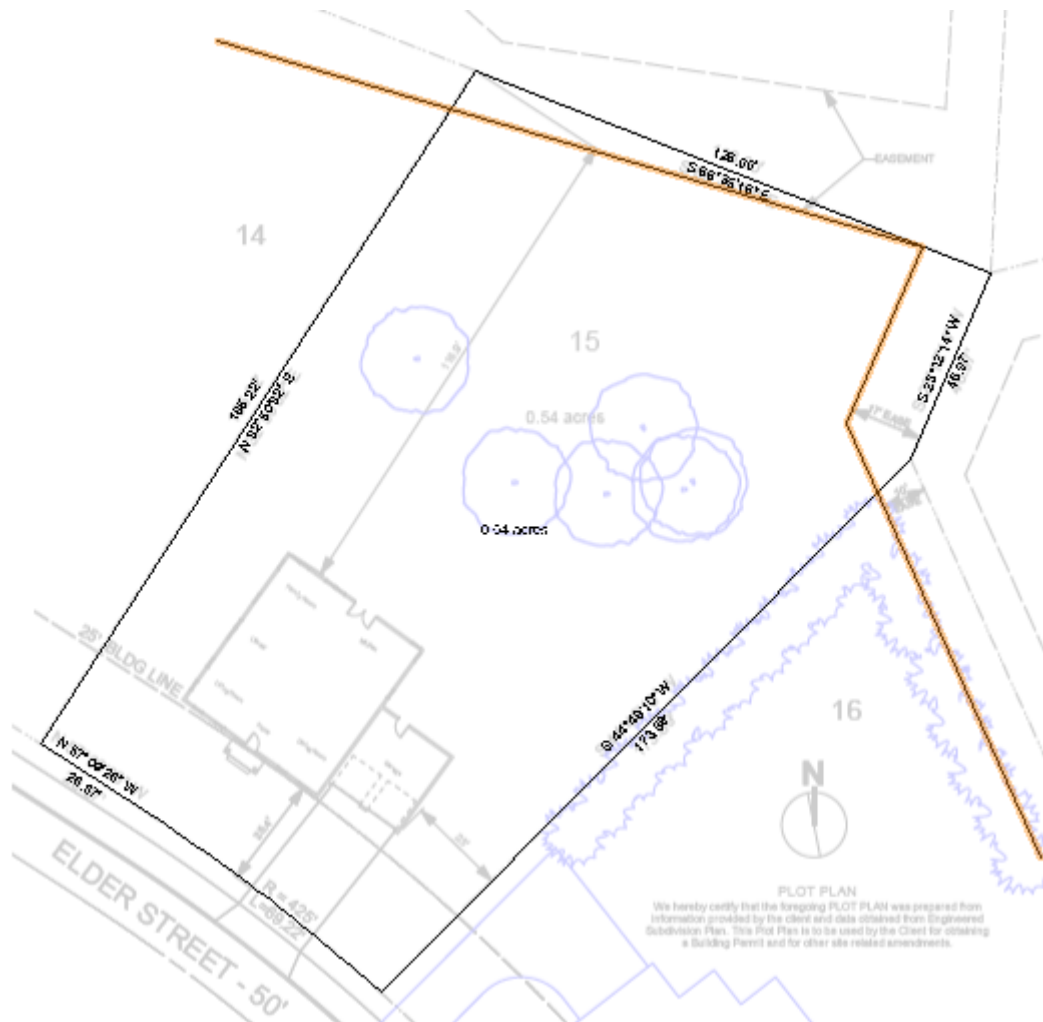

Note: To save time in this exercise, you ignore easement lines outside of the property line, and skip the process of recreating site dimensions.

- Save the file.

Exercise 5: Drawing the Site House

In this exercise, you save a rotated view, and then you draw a simplified version of the site house.

The completed exercise is shown in the following figure:

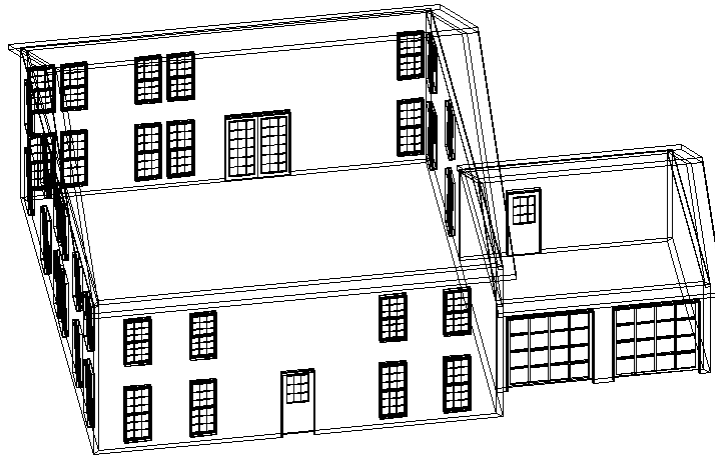

Saving a rotated view

You start the exercise by rotating the view, and then you save the view to ensure consistency when you draw objects orthogonally in other exercises later in the tutorial.

1. If you did not complete Exercise 4—or you are unsure of your file’s accuracy—open the **GS-VWLx04.vwx** file.
2. Zoom in on the house area (shown at left). In the View bar, click **Rotate Plan** . Snap to exterior endpoints (pause briefly over each vertex to display the Endpoint SmartCursor cue) in the order shown at center to rotate the plan view. Notice the indicator in the drawing area, and in the View bar, confirm that the Current Plan Rotation angle is 35.80° (if not, press Ctrl+Z to undo the view rotation and try again). Press Ctrl+6, and then zoom in on the area shown at right.

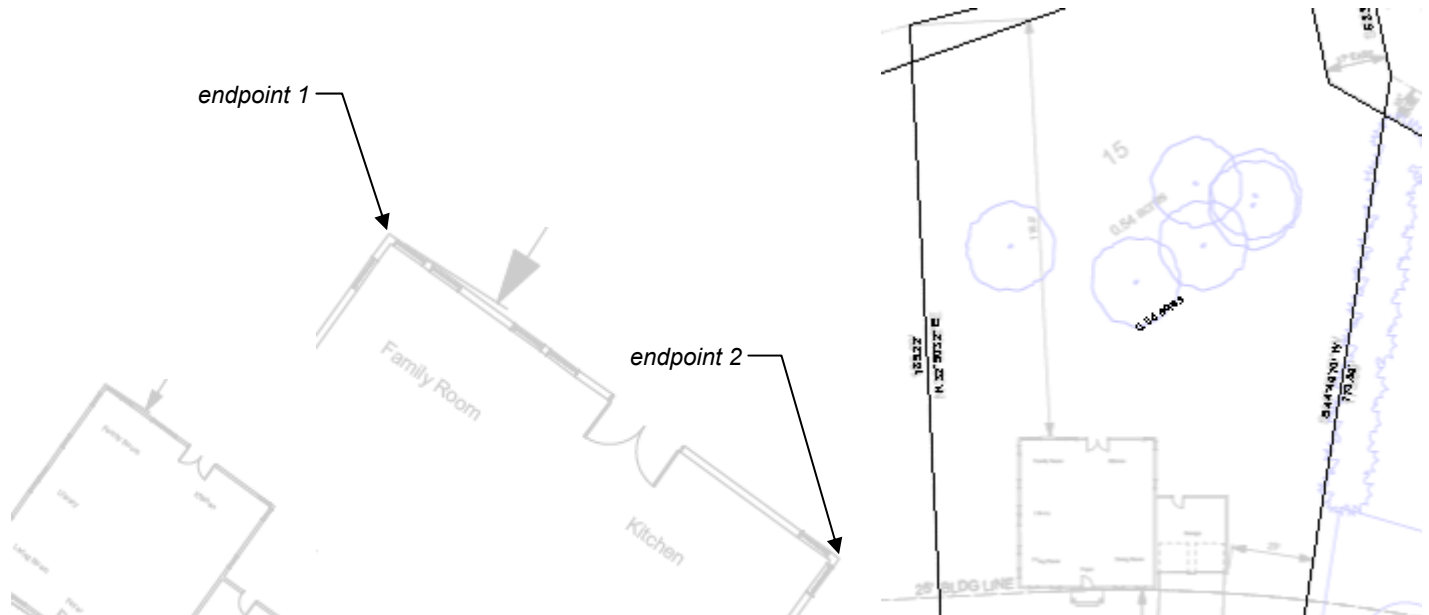

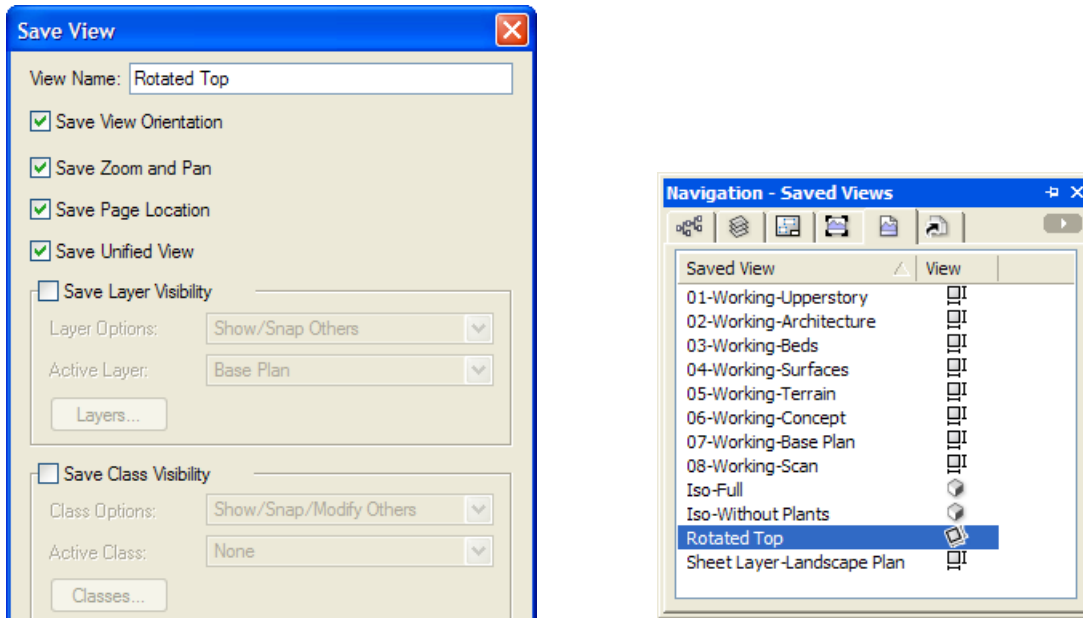

3. In the Navigation palette, select the Saved Views tab, and then right-click the blank area to the right of the list and select **New**. In the Save View dialog box, adjust the settings as shown at left (make sure the **Save Layer Visibility** and **Save Class Visibility** options are disabled), and then click **OK** to save the view. If necessary, resize the Navigation palette so all saved views are visible, and notice the new saved view's rotated view icon, as shown at right.



Drawing the house walls

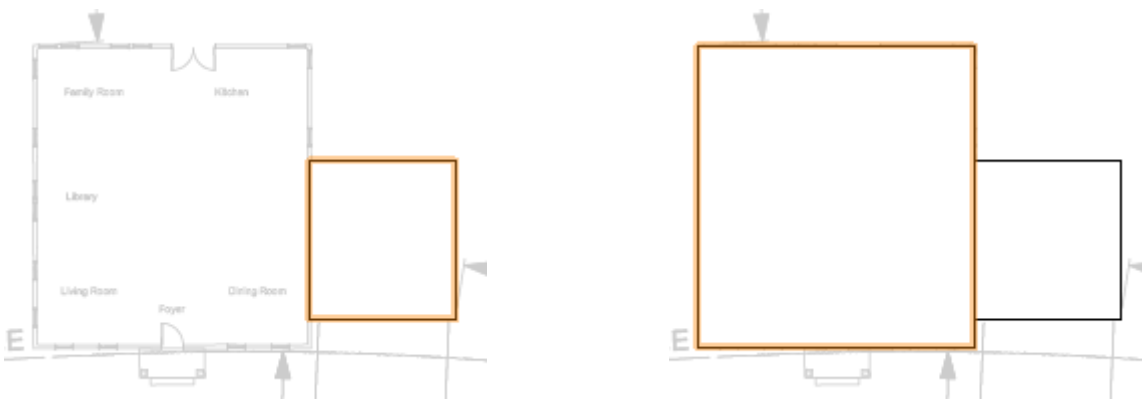

Next, you draw rectangles from the house outline for tracing purposes, and then you use pre-configured wall styles in your file to draw the existing house walls.

4. Zoom in on the house and garage. From the Basic tools palette, click the **Rectangle** tool . In the Tool bar, make sure **Rectangle Mode**  is active. Start by snapping to the top right outside corner of the garage wall, and then complete the rectangle by snapping to the point where the front garage wall meets the house wall, as shown at left. With the **Rectangle** tool still active, snap to top right outside corner of the house, and then snap to the bottom left outside corner to complete the second rectangle, as shown at right.



Notes:

- 1) You draw rectangles to ensure the house walls and roofs will be square. In your own designs, make sure the rectangle edges are collinear (it's not necessary for this tutorial because you use a supplied file with this fixed, later in [Exercise 14](#)).
- 2) If you don't have a floor plan to import in your own designs, refer to the *Getting Started with Vectorworks Architect (current version)* tutorial for an efficient workflow for drawing floor plans.

- Press the X key twice to clear the current selection. In the Navigation palette, select the Design Layers tab, and then turn off visibility of the **Scan** layer, as shown (only the rectangles are now visible). In the Resource Browser, scroll down and open the Wall Styles folder (if it's not open already). Double-click the **Ext-Siding-Framing** wall style. Open the Building Shell tool set, and notice that the **Wall** tool  is now active. In the Tool bar, make sure **Left Control Line Mode**  is active.

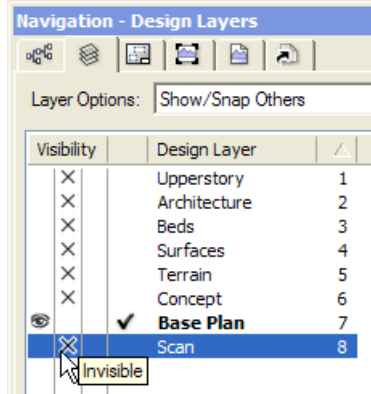

- Snap to the four corners of the house rectangle in clockwise order (starting on any corner), and then snap to the start point to create four walls, as shown left. With all four walls selected, in the Object Info palette, change the $\pm Z$ value to 17.00' [5.182m], as shown at right, and then press Enter.

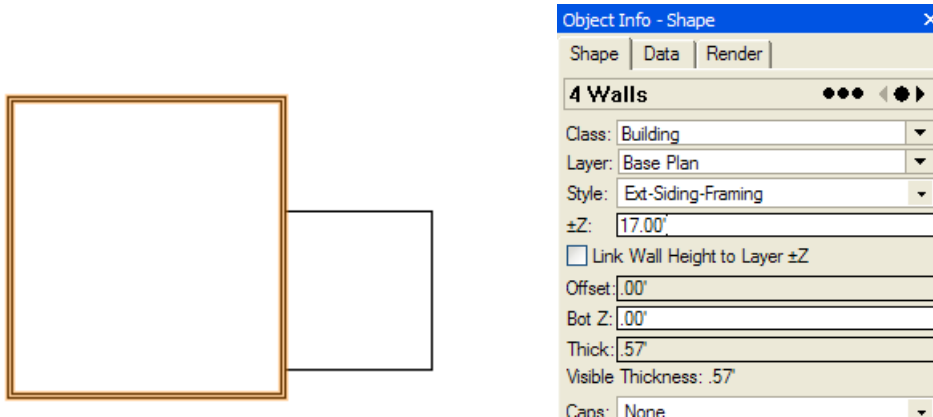

- With the **Wall** tool  still active, snap to the four corners of the garage rectangle in clockwise order. Start at the top left corner (when the house wall highlights), and when the house wall highlights at the bottom left corner, click to create three walls, as shown (do not change the $\pm Z$ value for the shorter garage walls).

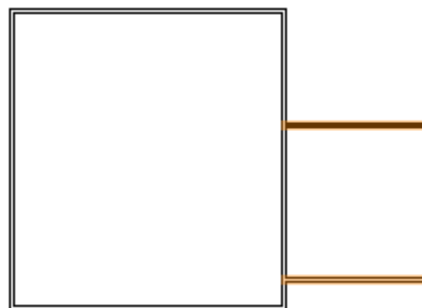

Drawing the house doors and windows

Next, you temporarily adjust the display so you can see the PDF page through the walls, and then you create doors and windows with the Door and Window tools, and by inserting pre-configured symbols.

8. Press the X key twice to clear the selection. In the Navigation palette:
 - Turn on visibility of the **Scan** layer, as shown at left. Notice that the rectangle and walls block objects in the PDF page.
 - Right-click the **Base Plan** layer, and select **Edit** from the context menu. In the Edit Design Layers dialog box, change the Opacity to 20%, as shown at right, and then click **OK**. Notice that you can now see objects in the PDF page.
 - Select the Saved views tab, and then double-click the **07-Working-Base Plan** saved view to activate it. Notice that the layer opacity doesn't revert to 100% because the pre-configured saved view is set to only control the visibility state of layers.

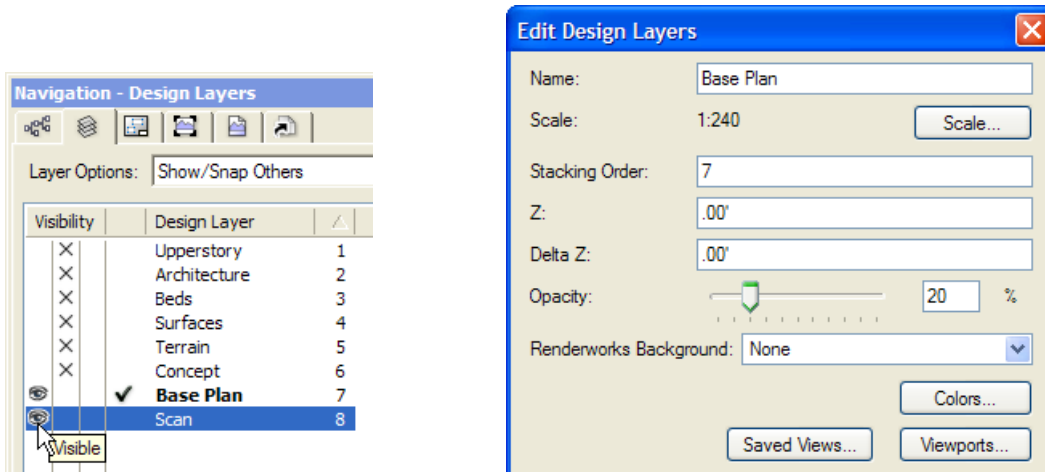

9. Zoom in on the house and garage. From the Building Shell tool set, click the **Door** tool . Click the center of the foyer door (click once) in the PDF page. Move your cursor, and notice how your cursor position flips the door side and swing. Click when the preview matches the orientation in the PDF page to place the door plug-in object as shown. In the Object Info palette, verify a "Door In Wall" is selected. If not, drag the door to reinsert it in the wall.

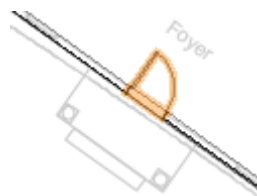

*Note: The **Door** tool was pre-configured for this file. The Door Settings dialog box would normally be displayed for the first door object inserted in a file. For subsequent insertions in your own files, click Preferences from the Tool bar before placing the door to set default door parameters. If you change Door Settings dialog box settings, all subsequent insertions are affected.*

10. With the **Door** tool still active, insert another door in the rear garage wall, matching the orientation in the PDF page, as shown.



11. In the Resource Browser, scroll down and open the Symbols/Plug-In Objects folder (if it's not open already). Scroll down the list and double-click the **Door-Patio** symbol. In the Basic tools palette, notice that the **2D Symbol Insertion** tool  is now active. Click once in the center of the rear door of the PDF page, and then click outside the wall to orient and insert the symbol, as shown.

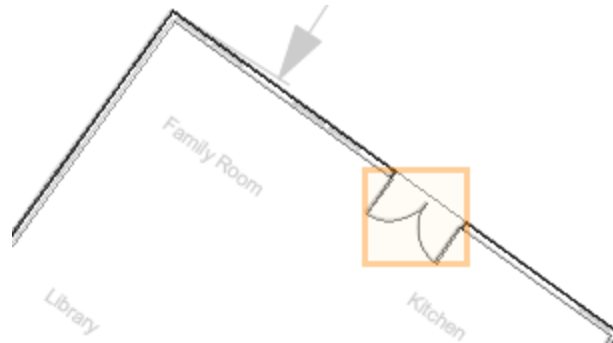

12. In the Object Info palette, verify a "Symbol In Wall" is selected. If not, drag the symbol to reinsert it in the wall. In the Resource Browser, scroll down the symbol list and double-click the **Door-Garage-OHD** symbol. Insert two garage doors, to match the position and orientation of the PDF page, where shown (highlighted for clarity) in the front garage wall.

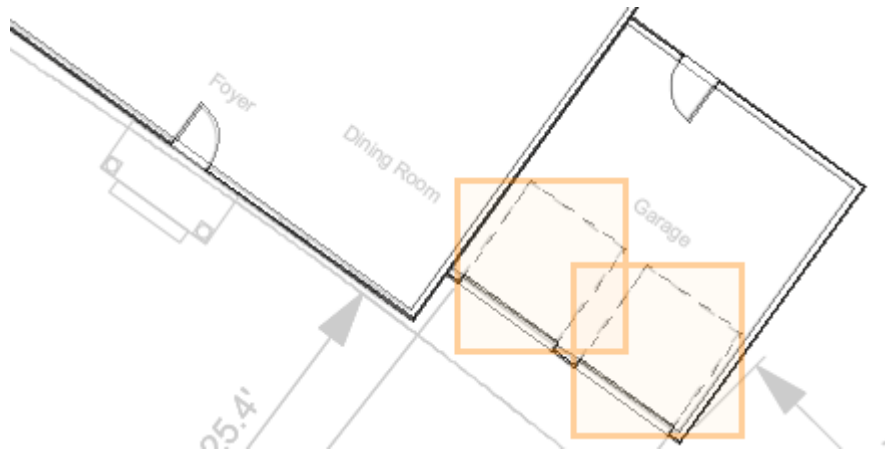

13. Zoom in on the house's front wall. From the Building Shell tool set, click the **Window** tool . Click the center of the window on the left side of the front door, and then click outside the wall to orient and place the window plug-in object, as shown. In the Object Info palette, verify a "Window In Wall" is selected. If not, drag the window to reinsert it in the wall.

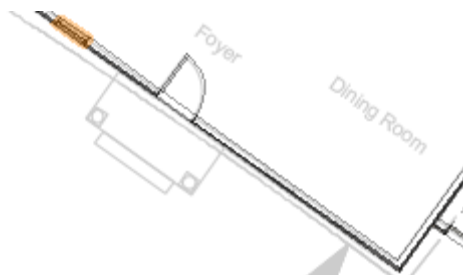

Note: The **Window** tool was pre-configured for this file. The **Window Settings** dialog box would normally be displayed for the first window object inserted in a file. For subsequent insertions in your own files, click **Preferences** from the **Tool bar** before placing the window to set default window parameters. If you change **Window Settings** dialog box settings, all subsequent insertions are affected.

14. With the **Window** tool still active, insert the remaining 16 windows by clicking the center to position them and then clicking outside the wall to orient them, as shown (all 17 windows are highlighted for clarity).



15. In the Navigation palette, select the Design Layers tab, and then:
- Turn off visibility of the **Scan** layer.
 - Right-click the **Base Plan** layer, and select **Edit** from the context menu. In the Edit Design Layers dialog box, change the Opacity to 100%, and then click **OK** to save the change.
16. In the Resource Browser, scroll down the symbol list and double-click the **Window-Floor2** symbol. Click the insertion point of each existing window, and then click outside to orient the symbol (see Note below). Start with the first window you created, and continue in a clockwise direction to insert a total of 17 window symbols (in the same positions highlighted in the previous figure).

Note: After inserting each window symbol, verify a “Symbol In Wall” is selected in the Object Info palette. If not, drag the symbol to reinsert it in the wall.

Creating the house roof from walls

Next, you create a roof object from the house walls.

17. If necessary, adjust the display so you can see the entire house and garage. Press the X key twice to clear the current selection and activate the **2D Selection** tool. Hold down the Shift key and click the four house walls (away from the windows; avoid selecting the garage walls) to add them to the current selection set. In the Object Info palette, verify that 4 walls are selected.

18. With the four walls still selected, select **Landmark > AEC > Create Roof** from the menu. In the Create Roof dialog box, change settings (.53' [.162m], .46' [.140m], 17.00' [5.182m], 1.00' [.305m]) as shown at left. Click **OK** to create the roof, and then press Ctrl+5 and Ctrl+6 to adjust the display. In the View bar, notice that the Upperstory layer is now active (so you can see the roof). Also notice that Vectorworks created a hip roof by default, as shown at right.

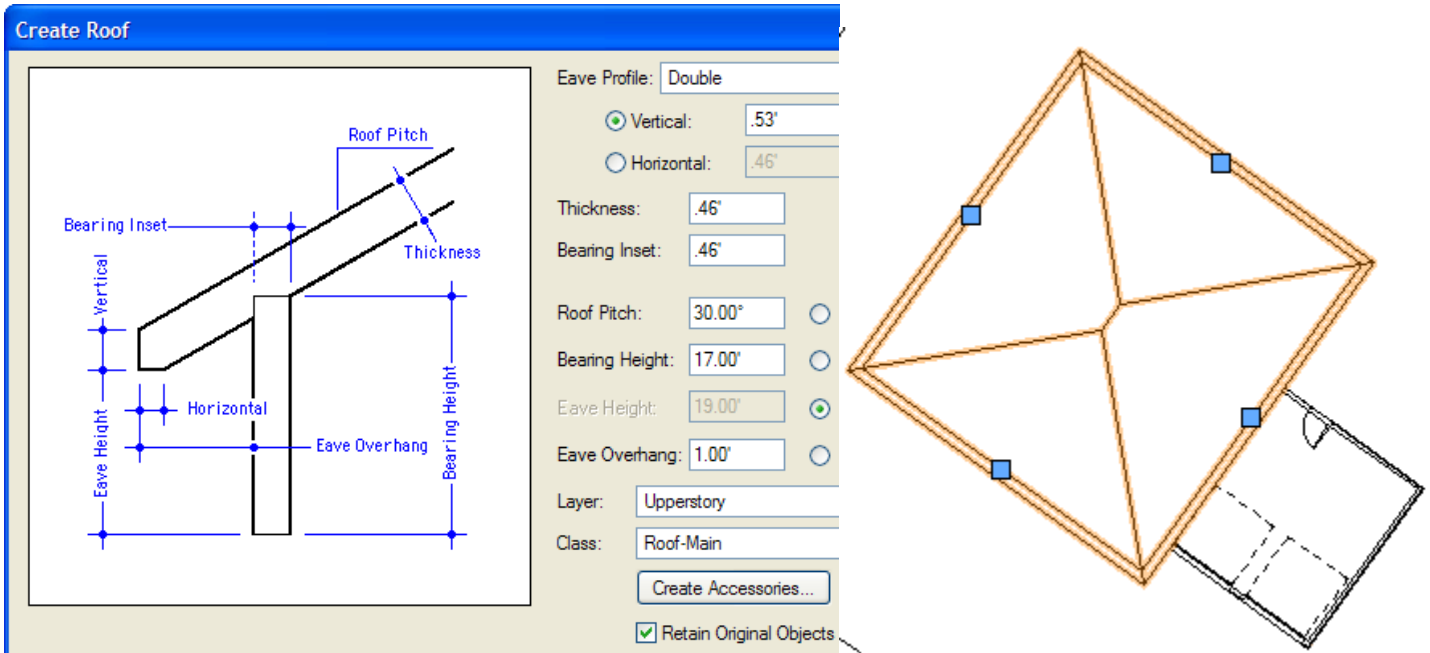

Next, you modify the roof to create the desired gabled ends.

19. Select the roof's center left control point, as shown at left. In the Edit Roof Settings dialog box, select the **Gable** option, and then click **OK** to create the gable end, as shown at right.

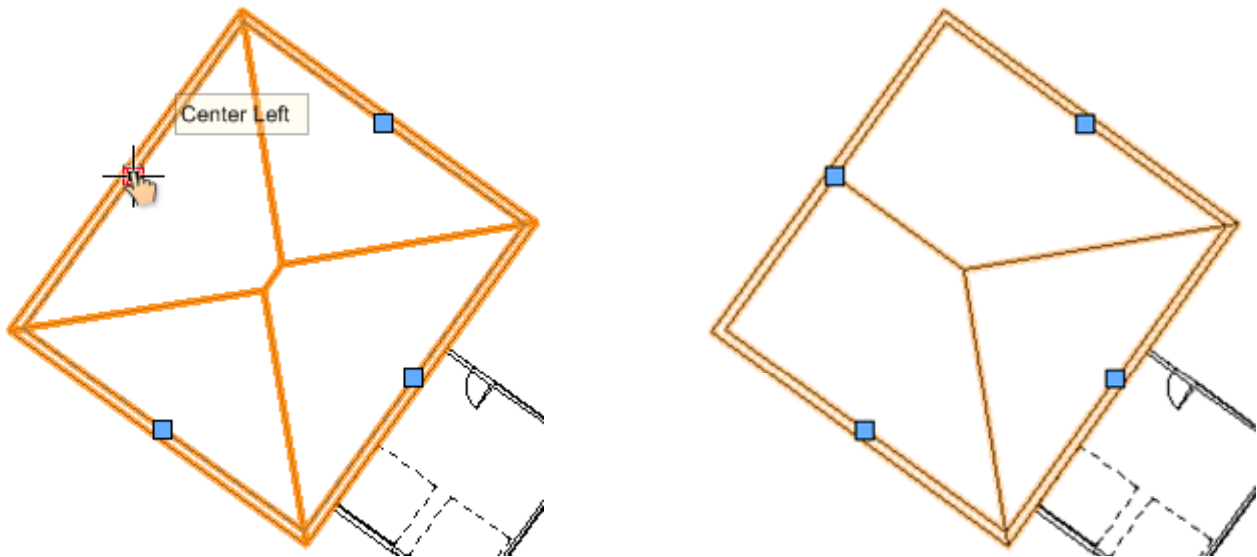

20. Repeat the process to change the center right side to a gable end, as shown.

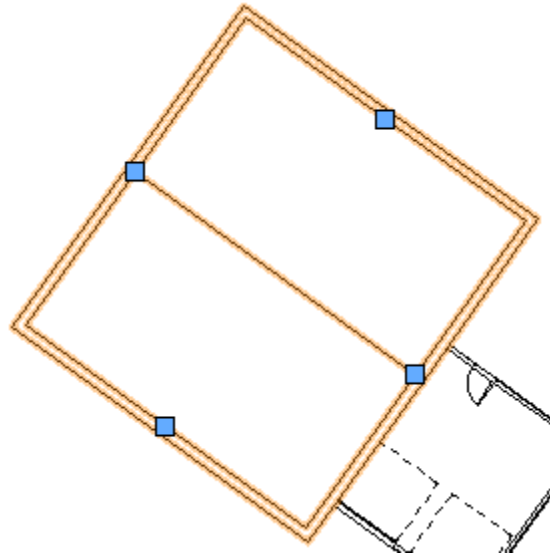

Creating the garage roof from a rectangle

Next, you use the garage rectangle (you drew earlier) to create the smaller roof over the garage.

21. In the Navigation palette, activate the **07-Working-Base Plan** saved view. Notice that the roof is no longer visible, because the Upperstory layer visibility is turned off in the 07-Working-Base Plan saved view.
22. Zoom in on the garage, and then press the X key, and click in the middle of the garage to select the rectangle. From the menu, select **Landmark > AEC > Create Roof**. In the Create Roof dialog box, change settings (.53' [.162m], .46' [.140m], 10.00' [3.048m], 1.00' [.305m]) as shown at left, and then click **OK** to create the roof. Press Ctrl+5 and Ctrl+6 to adjust the display, and examine the roof, shown at right.

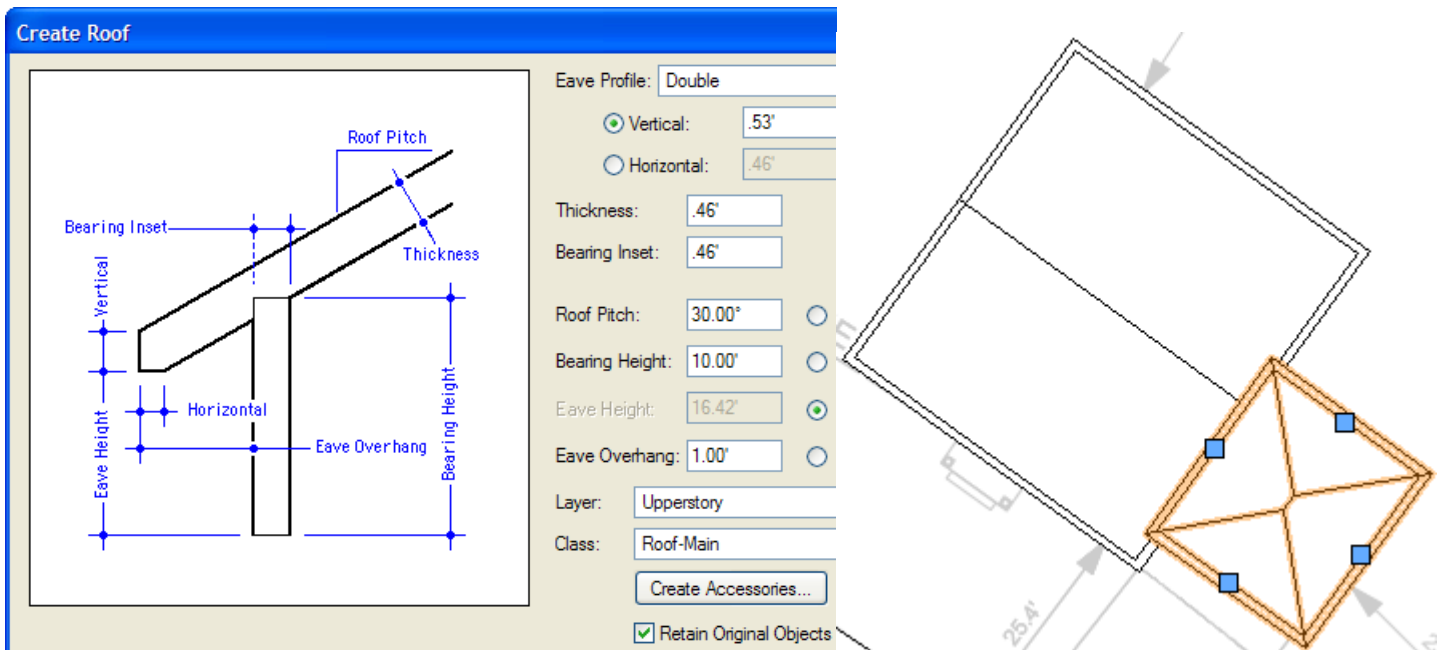

Notice that the garage roof now appears on top of the house roof— even though it's lower in elevation—because of the object *stacking order* (in this case, the display order is based on the order of object creation).

Next, you, modify the garage roof to remove the eave overhang on the house side, and then you create the desired gabled ends. You then complete the roofs by changing the stacking order of the house roof.

23. Select the garage roof's center left control point. In the Edit Roof Settings dialog box, select the **Gable** option, and then change the Eave Overhang to 0 (zero), as shown at left. Click **OK** to create the gable end and remove the overhang, as shown at right.

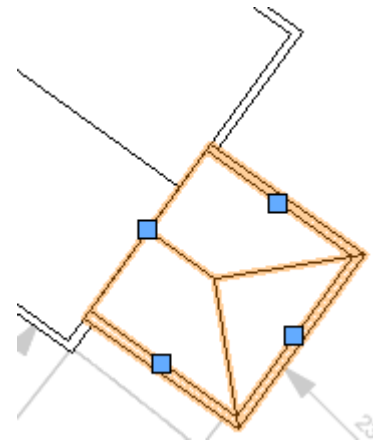
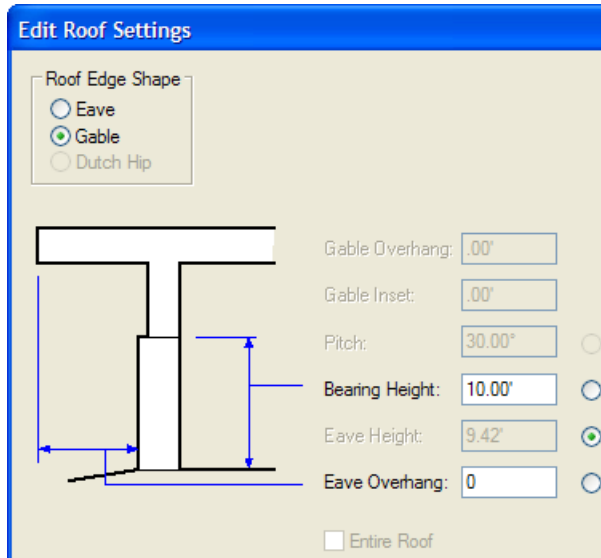

24. Repeat the process to change the garage roof's center right side to a gable end (but do not change the Overhang value), as shown at left. Right-click the house roof and select **Send > Send to Front** from the context menu. Press the X key twice to clear the current selection, and notice that the house roof is now on top of the garage roof, as shown at right.

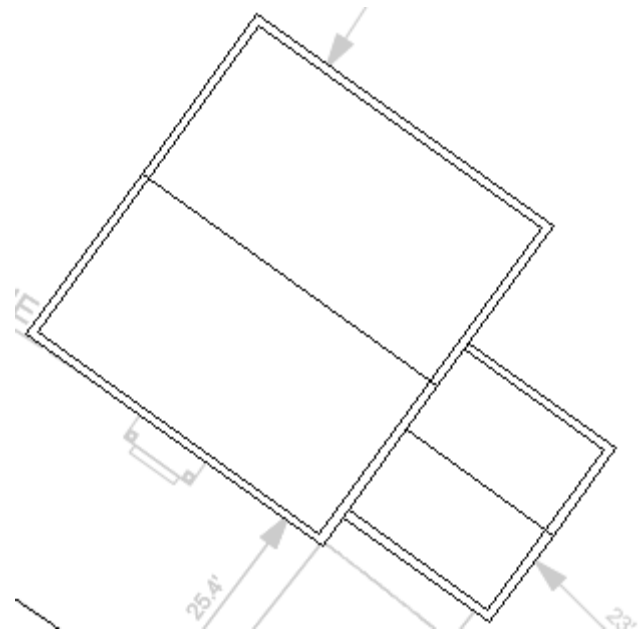
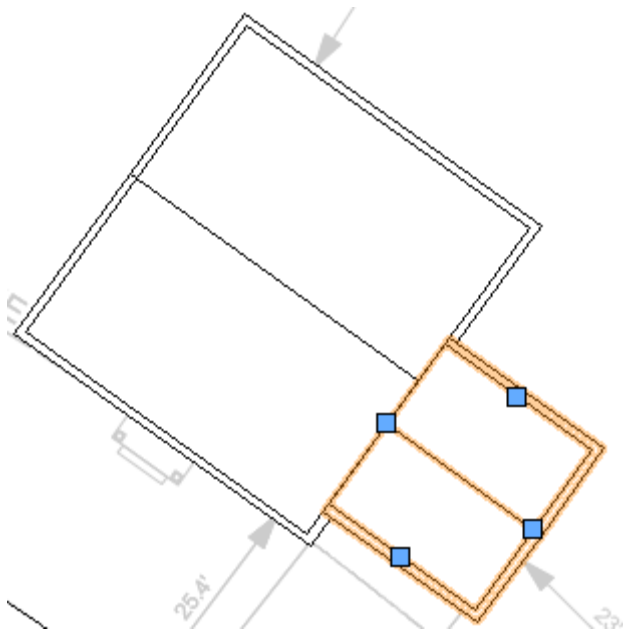

25. From the View bar, select the  **Left Isometric** view from the Standard View drop-down list. Press Ctrl+6 to adjust the display, and then zoom in on the house and examine the 3D geometry of all the objects you created, as shown.

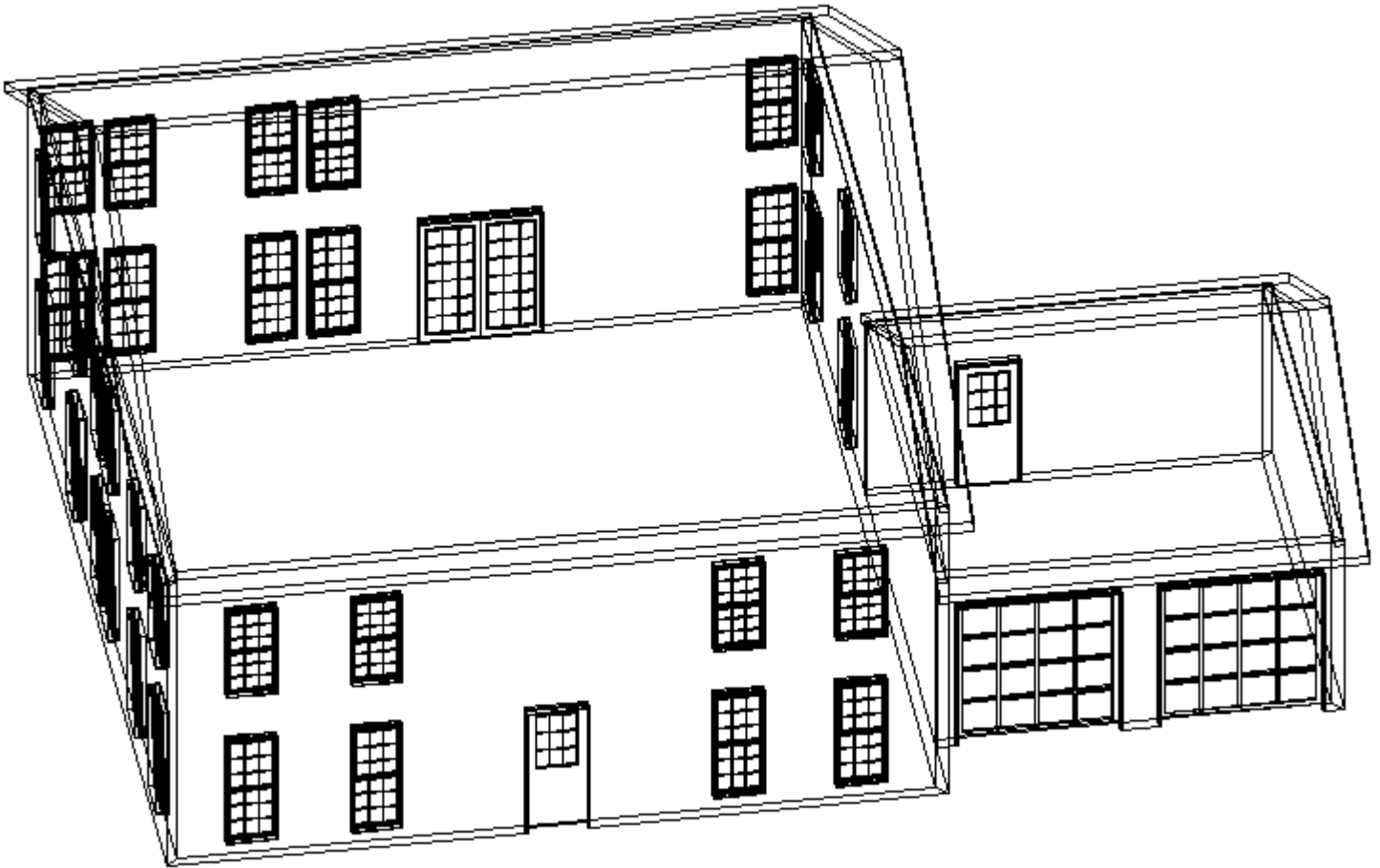

26. Save the file.

Exercise 6: Drawing the Adjacent House

In this short exercise, you create a massing model to represent the house next door.

The completed exercise is shown in the following figure:

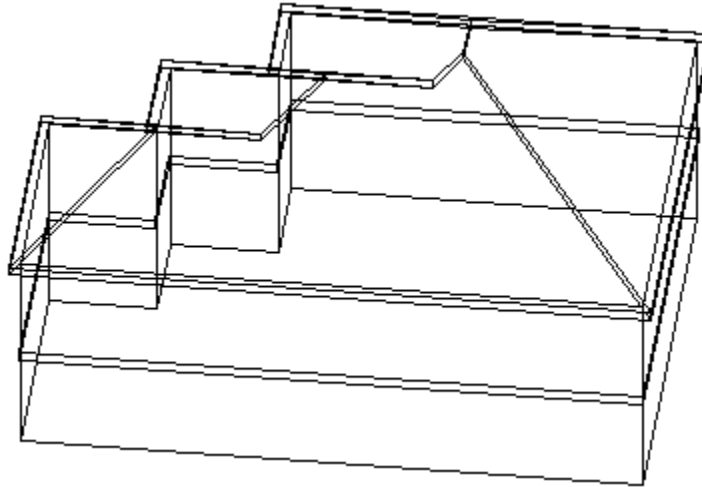



Creating a massing model

You start the exercise resetting the view, and then you activate the **Massing Model** tool and trace the outline of the neighbor's house on the PDF page.

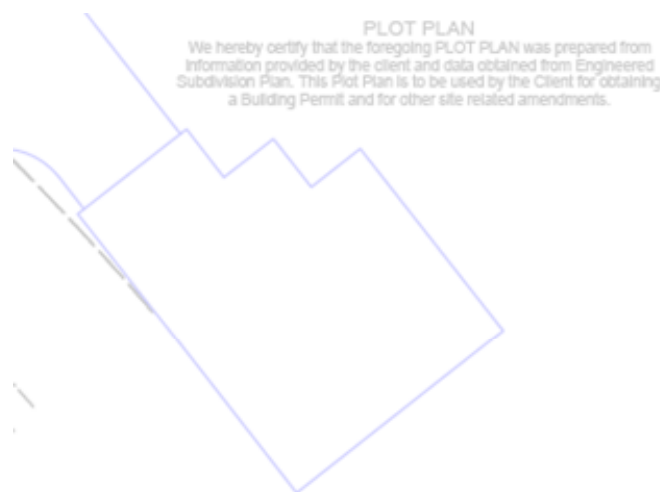
1. If you did not complete Exercise 5—or you are unsure of your file's accuracy—open the **GS-VWLx05.vwx** file.
2. In the Navigation palette, activate the **07-Working-Base Plan** saved view (you may need to activate it twice to restore the Top/Plan view). In the Basic tools palette, click the **Pan** tool , and then pan the view by “dragging” the neighbor's house to the approximate center of the screen. Zoom in on the area shown.



- From the Site Planning tool set, click the **Massing Model** tool . In the Tool bar, make sure **Corner Vertex Mode**  is active. Starting at the bottom vertex, snap to vertices in a clockwise order. Double-click the far right (next to last) vertex to automatically close the profile, and create the massing model, as shown (leave the massing model selected for the next step).

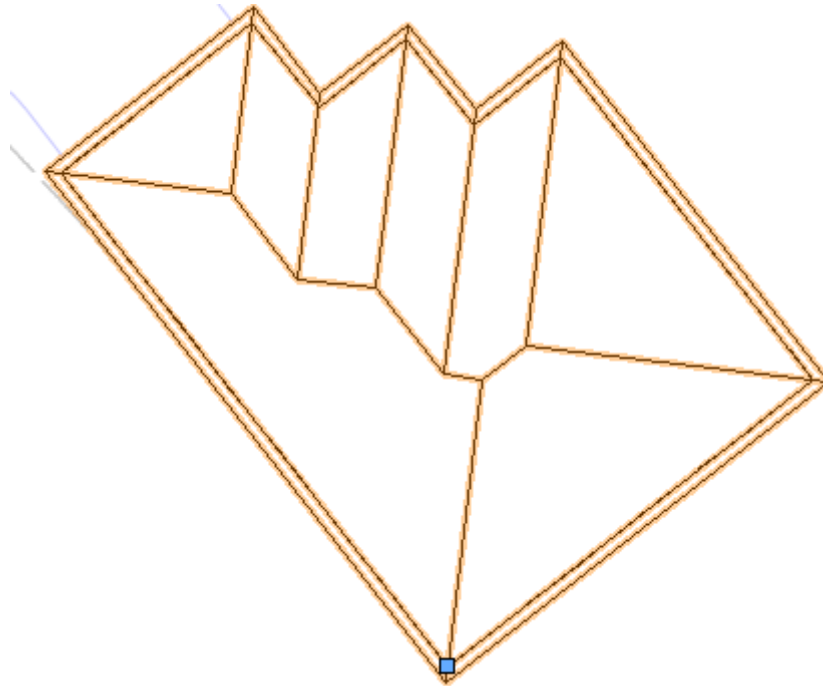

*Note: The **Massing Model** tool was pre-configured for this file. The Object Properties dialog box would normally be displayed for the first massing model object inserted in a file. For subsequent insertions in your own files, click Preferences from the Tool bar before creating a massing model to set default parameters. If you change settings in the Object Properties dialog box, all subsequent insertions are affected.*

- In the Object Info palette, change the massing model's Class to **Existing-remain**, (enable the option and click **Yes** in the dialog box shown at left). From the View bar, select the  **Left Isometric** view from the Standard View drop-down list. Press Ctrl+6 to adjust the display, and then press the X key twice to clear the selection, and examine the completed massing model, as shown.

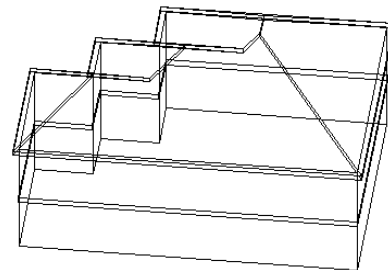
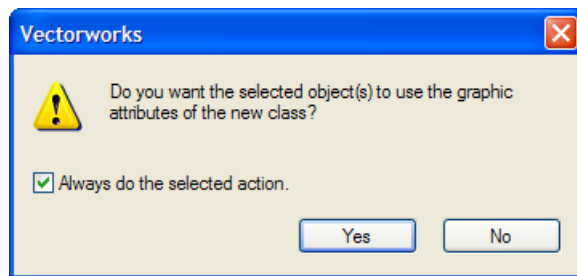

- Save the file.

Exercise 7: Drawing the Paved Areas

In this exercise, you use various tools to draw the existing driveway, front porch, sidewalk, and streets.

The completed exercise is shown in the following figure:

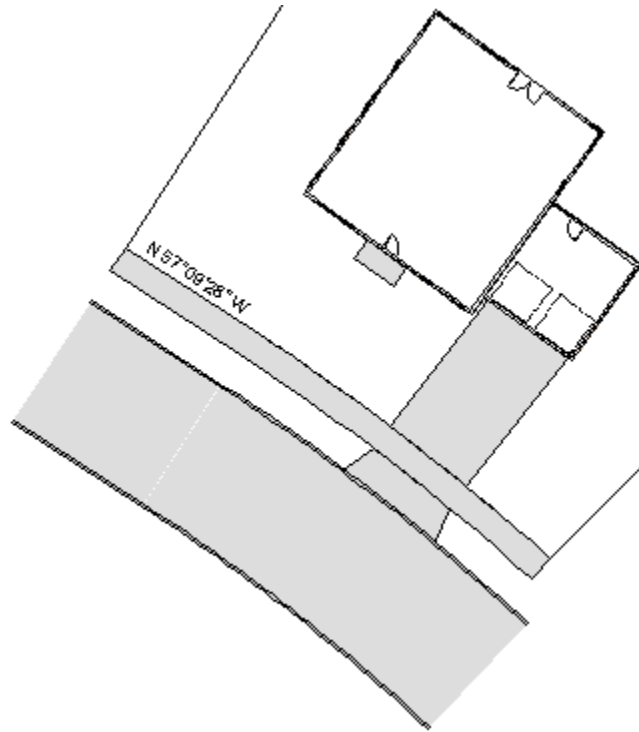



Drawing the driveway

You start the exercise by adjusting layer and class visibilities, and then you use the **Hardscape** tool to draw the driveway and apron.

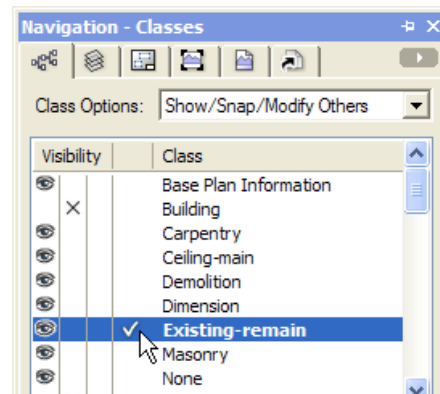
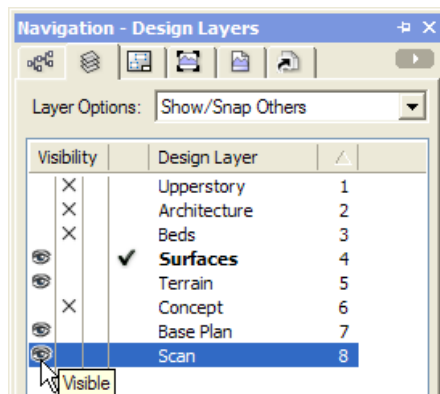
1. If you did not complete Exercise 6—or you are unsure of your file’s accuracy—open the **GS-VWLx06.vwx** file.
2. In the Navigation palette:
 - Activate the **04-Working-Surfaces** saved view (you may need to activate it twice to restore the Top/Plan view).
 - Select the Design Layers tab, and turn on visibility of the **Scan** layer (shown at left) so you can see the PDF page.
 - Select the Classes tab, and turn off visibility of the **Building** class, and activate the **Existing-remain** class, as shown at right.



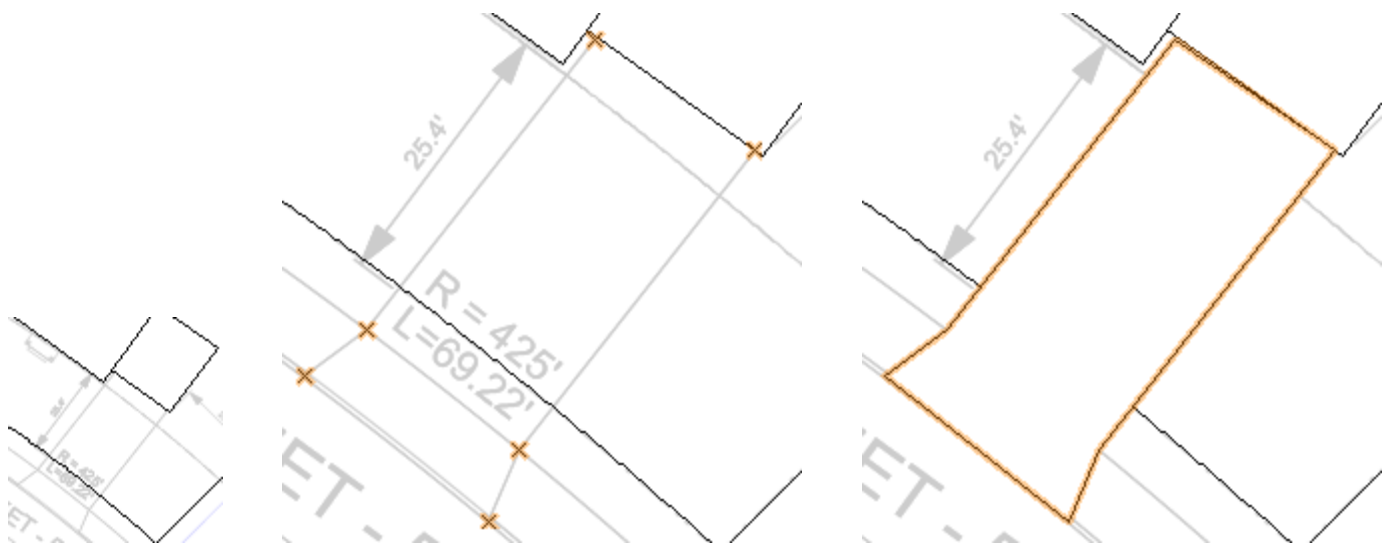

3. Zoom in on the area shown at left. From the Site Planning tool set, click the **Hardscape** tool . In the Tool bar, make sure that **Corner Vertex Mode**  is active, and then click **Preferences** . If they're not already selected, select **By Class** from both the Main Texture and Border Texture drop-down lists. Click the boundary vertices (shown at center as highlighted locus points for clarity) in clockwise order starting at the lowest vertex, and then click the start point again to create the hardscape object, shown at right (leave the hardscape selected for the next step).



Note: The Hardscape tool was pre-configured for this file. The Hardscape Object Settings dialog box would normally be displayed for the first door object inserted in a file. For subsequent insertions in your own files, click Preferences from the Tool bar before creating a hardscape to set default parameters. If you change settings in the Hardscape Object Settings dialog box, all subsequent insertions are affected.

Next, you reshape the hardscape object so that it's flush with the front garage wall.

4. Zoom in on the area shown at left. Press the X key, then double-click the hardscape object to activate the **2D Reshape** tool . In the Tool bar, make sure **Move Polygon Handles Mode**  is active. Click the top left grip to "pick up" the vertex. Move your cursor over the left driveway line, and press the T key to set the surface snap. Move your cursor over the front edge of the garage rectangle, and press the T key to set another surface snap. Move your cursor to the intersection of both surfaces, and press the Z key (press it again if necessary), and then click when the Surface/Surface SmartCursor cue is displayed (shown at center). The driveway hardscape maintains its width and is now flush with the garage front edge, as shown at right.

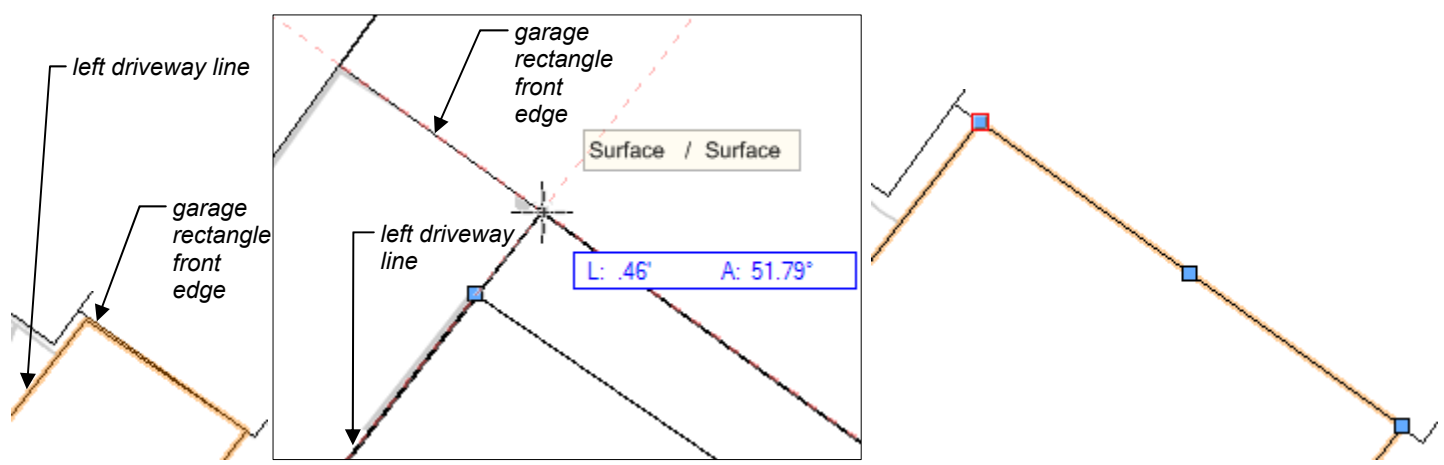

5. Press Ctrl+6, and then press the X key twice to clear the selection, and examine the completed driveway hardscape, as shown at right.

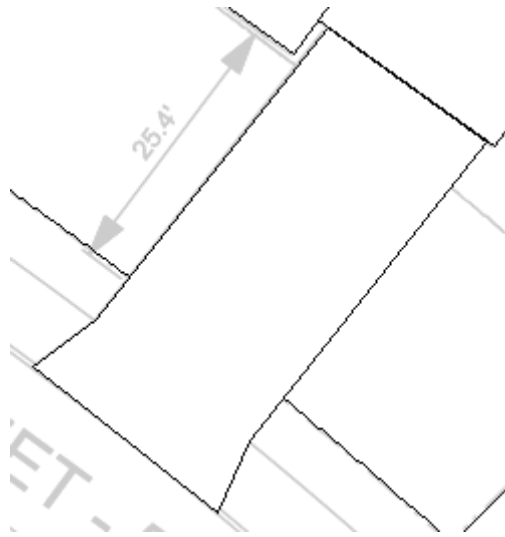

Drawing the front porch

Next, you draw another boundary hardscape for the front porch.

6. Zoom in on the area shown at left. Zoom in on the area shown at left. From the Site Planning tool set, click the **Hardscape** tool . Snap to the porch's boundary vertices (press the Z key as necessary) to create the hardscape, as shown at right, and then press the X key twice to clear the selection.

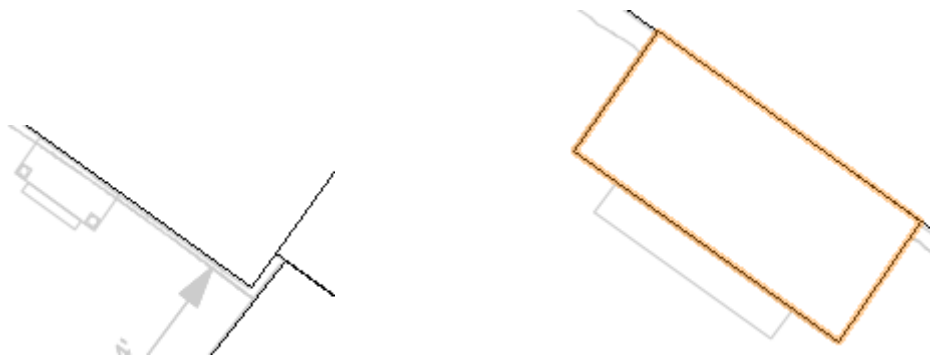

Note: To save time, you ignore the front porch step in the PDF page.



Drawing the sidewalks

Next, you create the sidewalk by drawing individual polyline and line objects, which you then compose into a polyline that you convert to a hardscape object.



7. In the Navigation palette:

- Select the Saved Views tab, and then activate the **07-Working-Base Plan** saved view, and then zoom in on the area shown.
- Select the Design Layers tab, and then turn off visibility of the **Scan** layer.

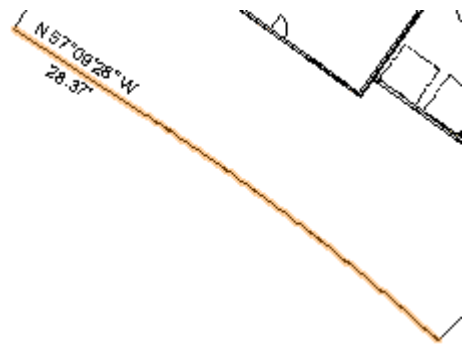
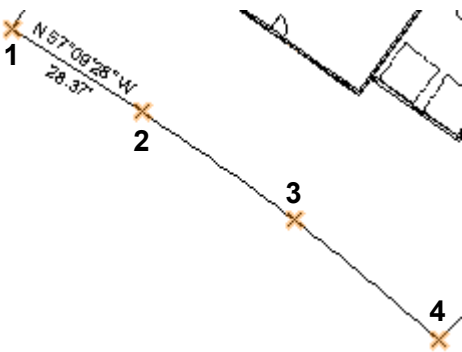

8. From the Basic tools palette, click the **Polyline** tool . In the tool bar, enable **Corner Vertex Mode** , and then snap to vertices 1 and 2 (shown at left as highlighted locus points for clarity) in order. After you snap to vertex 2 (arc start), enable **Point on Arc Mode**  in the Tool bar, and snap to vertex 3 (arc midpoint), then double-click vertex 4 to complete the polyline shown at right (leave the polyline selected for the next step).



9. In the Navigation palette, turn on visibility of the **Scan** layer. From the Basic tools palette, click the **Offset** tool . In the Tool bar, enable **Offset by Point Mode**  and **Duplicate and Offset Mode** . Click the endpoint shown at left, then wait for the duplicate preview display, and then click it again to create an offset duplicate of the polyline, as shown at right.

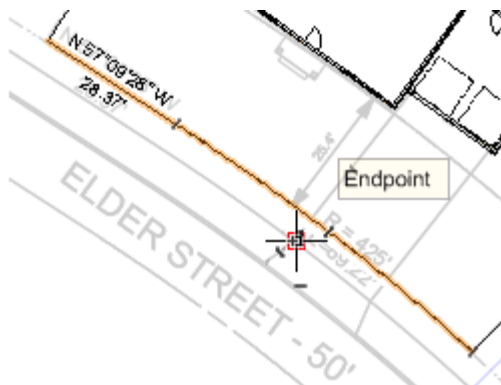

10. From the Basic tools palette, click the **Line** tool . Snap to the endpoints of both polylines to create two lines, as shown at left (highlighted for clarity). Press the X key and then draw a marquee from top left to bottom right, as shown at center to select the arcs and lines (confirm 4 objects are selected in the Object Info palette). From the menu, select **Modify > Compose**. The lines and arcs are combined into a single polyline object, as shown at right (leave the polyline selected for the next step).



11. From the menu, select **Modify > Convert > Objects from Polyline**. In the Create Objects from Polyline dialog box, adjust settings as shown, and then click **OK** to create the hardscape object. In the Object Info palette, change the hardscape object's:
- Class to **Existing-remain**
 - Layer to **Surfaces** (the hardscape disappears, and the Object Info palette shows “No Selection” because the Surface layer is currently invisible)

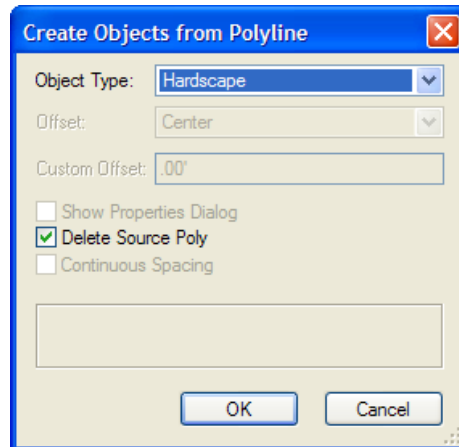

Next, you use the **Clip Surface** command with the hardscape objects to subtract the area of the sidewalk from the driveway.

12. In the Navigation palette, activate the **04-Working-Surfaces** saved view. Press the X key, and then hold down the Shift key and select the driveway to add it to the selection (in the Object Info palette, verify that two hardscape objects are selected). Right-click the selection, and then select **Clip Surface** from the context menu. Select only the driveway apron and notice that the area of the sidewalk was removed from it, as shown.

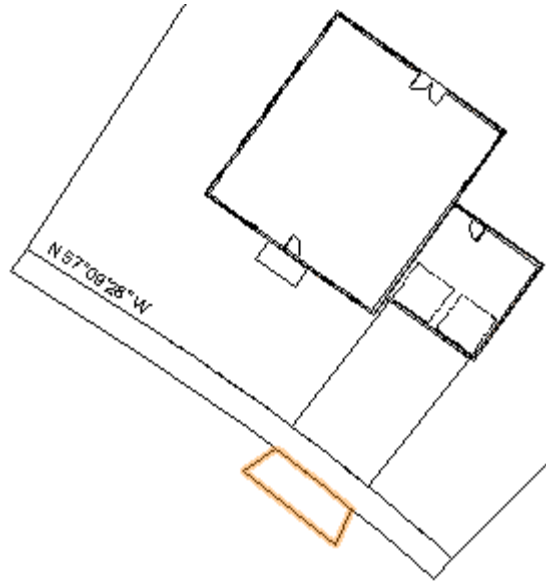

Drawing the straight road segment

Next, you use the **Roadway (Straight)** tool to draw the straight portion of the road. You draw the roadway object on the sidewalk edge to facilitate snapping (in this site, the sidewalk and road centerlines are parallel), and then you move it into place later.

13. Zoom in on left half of the sidewalk, as shown at left. From the Site Planning tool set, click the **Roadway (Straight)** tool , and then snap to the point where the sidewalk's straight segment meets the arc, as shown at center. Click the sidewalk's left endpoint (shown at right) to complete the straight roadway segment.

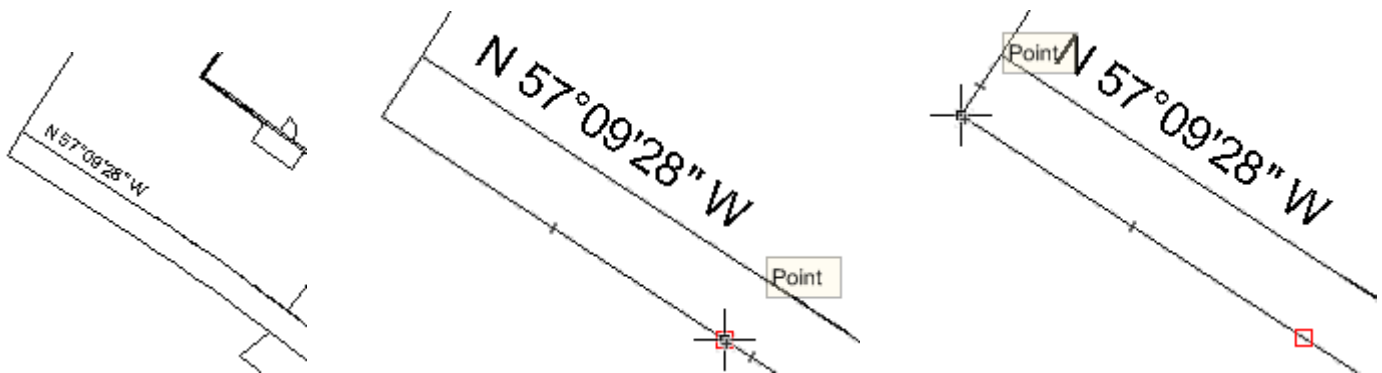

Note: The **Roadway (Straight)** tool was pre-configured for this file. The **Roadway (Straight)** dialog box would normally be displayed for the first straight roadway object inserted in a file. For subsequent insertions in your own files, click **Preferences** from the **Tool bar** before creating a straight roadway to set default parameters. If you change settings in the **Roadway (Straight)** dialog box, all subsequent insertions are affected.

Drawing the curved road segment

Next, you use the **Roadway (Curved)** tool to draw the arc portion of the road, and then you move and rotate it into position.

14. From the Site Planning tool set, click the **Roadway (Curved)** tool . Double-click the top right corner of the straight roadway segment. After a few seconds, the curved roadway object is created. Press Ctrl+6 so you can see it, and then press the X key and drag the curved segment close to the straight segment as shown at left. Zoom in on the area between the two roadway objects, as shown at right.



*Note: The **Roadway (Curved)** tool was pre-configured for this file. The **Roadway (Curved)** dialog box would normally be displayed for the first curved roadway object inserted in a file. For subsequent insertions in your own files, click **Preferences** from the **Tool bar** before creating a curved roadway to set default parameters. If you change settings in the **Roadway (Curved)** dialog box, all subsequent insertions are affected.*

15. Press the X key, and then drag the curved roadway object by its top left corner and snap it to the straight roadway object's top right corner (if necessary, press the Z key to temporarily zoom in), as shown at left. From the Basic tools palette, click the **Rotate** tool . For the center of rotation, snap to the endpoint where it meets the straight roadway object, as shown at left. Snap to the other endpoint of the curved roadway object (shown at center) to set the reference angle. Snap to the other endpoint of the straight roadway object (shown at right) to specify the new angle and complete the rotation (leave the curved roadway object selected for the next step).

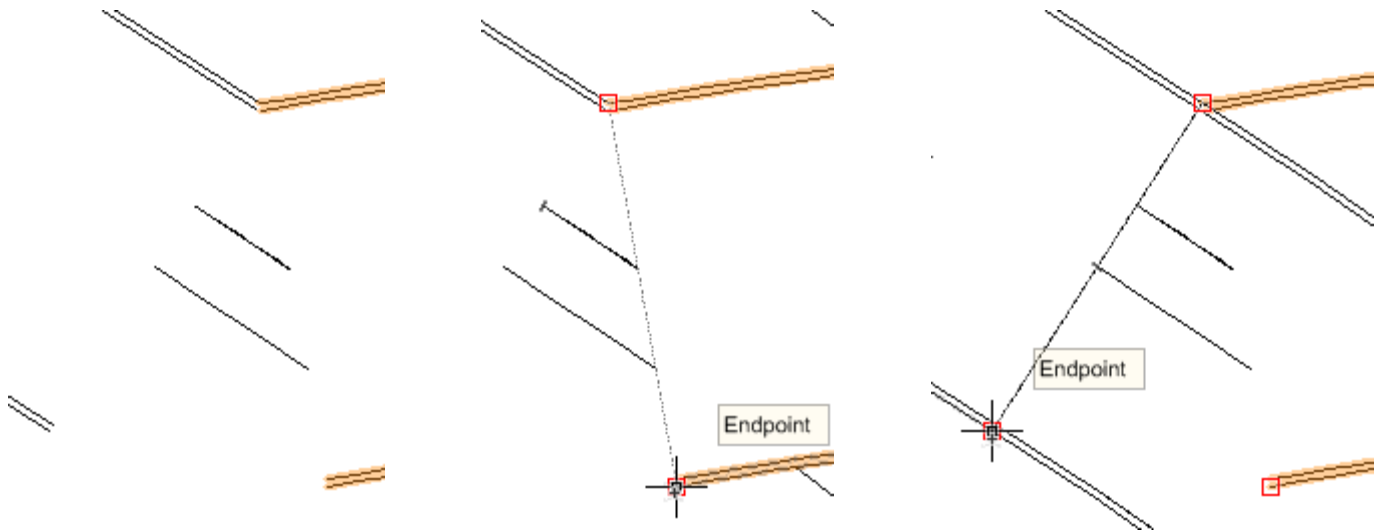

Tip: You can snap to any points on the roadway edges to specify the reference and new angles (you don't have to align points on the same radius).

Next, you turn on visibility of the PDF page, and then you use the **Move by Points** tool to move both roadway objects into position.

16. In the Navigation palette, select the Design Layers tab, and then turn on visibility of the **Scan** layer. Press the X key, and then hold down the Shift key and select the straight roadway object (2 objects should now be selected). From the Basic tools palette, select the **Move by Points** tool . For the start point, snap to the insertion point of the straight roadway, as shown at left. For the end point, snap to the arc endpoint of the road centerline (shown at center) to move the roadway objects into place, as shown at right (leave both roadway objects selected for the next step).

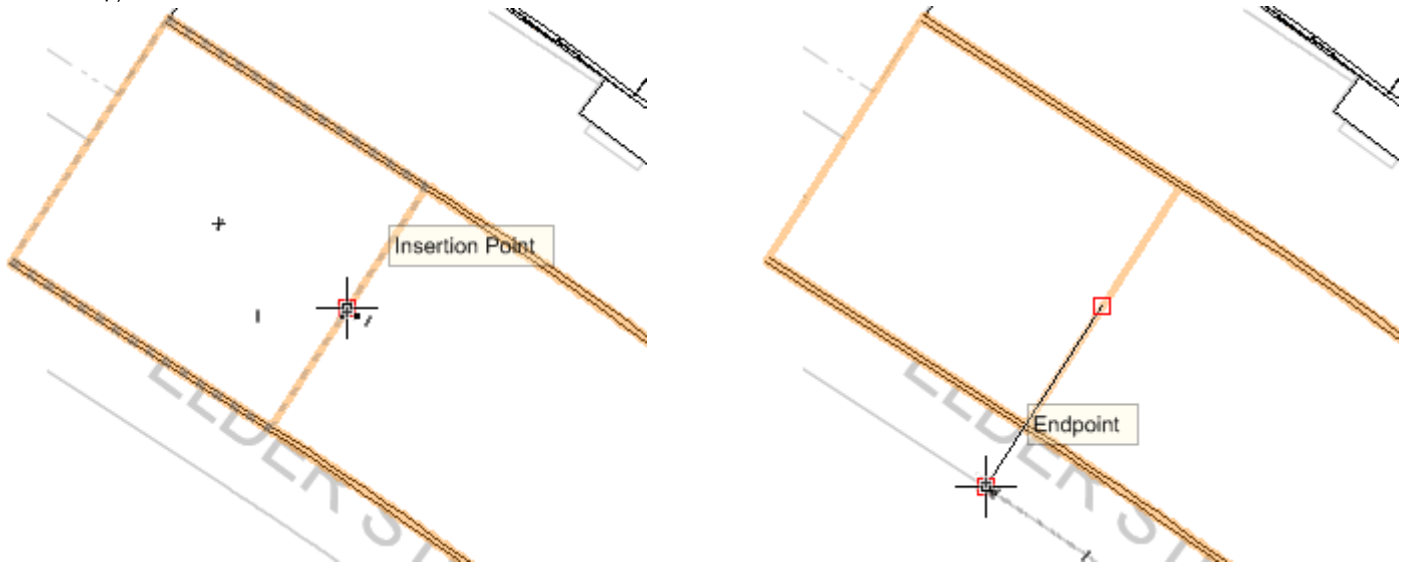

17. In the Object Info palette, change the class of both roadway objects to **Existing-remain**. Press the X key, and then hold down the Shift key and select the porch, sidewalk, and both driveway hardscapes to add them to the current selection (6 objects should be selected). In the Attributes palette, click the **Solid Fill Color** button, and select the gray color shown at left. Press the X key twice, then activate the **04-Working-Surfaces** saved view, and examine the completed paved areas, as shown at right.

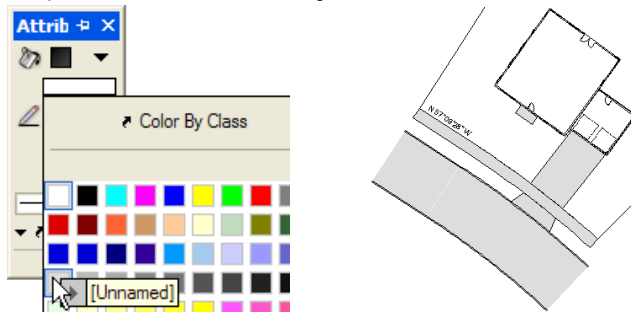

18. Save the file.

Exercise 8: Drawing Existing Vegetation



In this exercise, you draw trees to be demolished to make room for new landscaping features, and you draw trees in the adjacent lot.

The completed exercise is shown in the following figure:



Drawing existing trees for removal

You start the exercise by drawing existing trees in the back yard that will be demolished.

1. If you did not complete Exercise 7—or you are unsure of your file's accuracy—open the **GS-VWLx07.vwx** file.
2. In the Navigation palette, activate the **07-Working-Base Plan** saved view. From the Site Planning tool set, click the **Place Plant** tool . In the Place Plant Preferences dialog box, select **Existing Tree-Demolition** from the Symbol list (shown at left; 18.00' [5.486m]), and then click **OK**. In the Tool bar, enable **Single Plant Placement Mode** . To place the first tree, click the center of the tree "sketched" on the PDF page, where shown at center. The tree is then created, as shown at right.

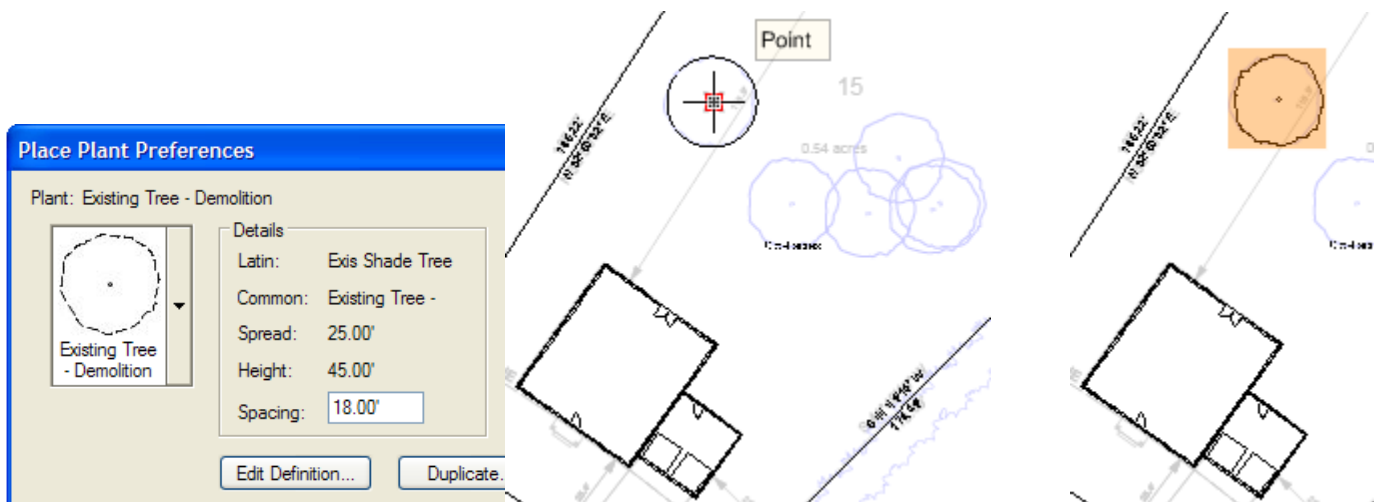



Note: Only symbols with the "Generic" prefix are in blank files by default. The other symbols were included in the starting file to save time.

- Continue clicking the centers of the "sketched" trees to create all six trees. Press the X key, and then hold down the Shift key and select all six trees. In the Object Info palette, change the Class to **Demolition**. Press the X key twice to clear the selection and examine the trees, as shown.



Drawing existing trees to remain

Next, you draw a line of existing trees in the neighbor's yard.

- From the Site Planning tool set, click the **Place Plant** tool . In the Tool bar, enable **Poly-Edge Spaced Mode** , and then click **Preferences** . In the Place Plant Preferences dialog box, adjust settings (10.00' [3.048m]) as shown at left, and then click **OK**. Click the three points (shown at center as highlighted 2D locus points for clarity) from left to right approximately where shown. Double-click the lower right point to terminate the line. After several seconds, the plant object is created, as shown at right (leave the plant object selected for the next step).

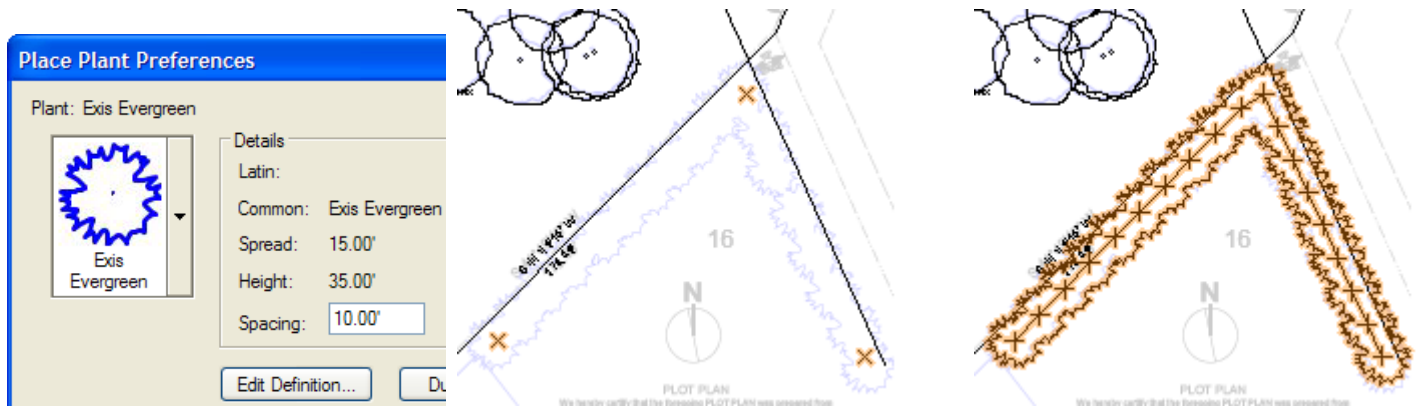

Note: The **Place Plant** Preferences dialog box is only displayed for the first plant object inserted in a file. For subsequent insertions, click **Preferences** from the Tool bar before placing the plant to set default plant parameters. If you change settings in the Place Plant Preferences dialog box, all subsequent insertions will be affected.

5. In the Object Info palette, verify or adjust settings (10.00' [3.048m]), as shown at left, and then press the X key twice to clear the selection, and examine the completed existing trees, as shown at right.

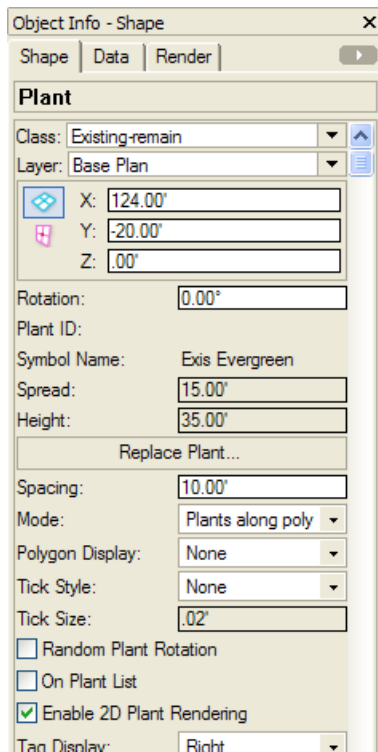

6. Save the file.

Section 3: Laying out Constructed Elements

In four exercises, this section covers the following processes in the landscape design project:

- Creating a privacy fence from walls (pg 44)
- Laying out the pool area with construction geometry (pg 50)
- Inserting the pool symbol (pg 54)
- Drawing the pool deck (pg 54)
- Drawing the pool house walls (pg 55)
- Drawing the pool house roof (pg 57)
- Drawing the seat wall (pg 58)
- Drawing the seat wall cap (pg 59)
- Mirroring objects (pg 59)
- Inserting the pergola symbol (pg 61)
- Inserting the gazebo symbol (pg 63)
- Inserting the bench symbol (pg 64)

In these exercises, you start developing landscaping features by creating the following construction elements to delineate key landscaping and activity areas that drive the design:

- Create a privacy fence
- Insert the pool symbol and draw the decking and pool house
- Draw the seat walls
- Insert pre-configured symbols for the pergola, gazebo, and seating features

Exercise 9: Drawing the Privacy Fence

In this exercise, you use existing geometry to create a privacy fence made of wall objects.

The completed exercise is shown in the following figure:

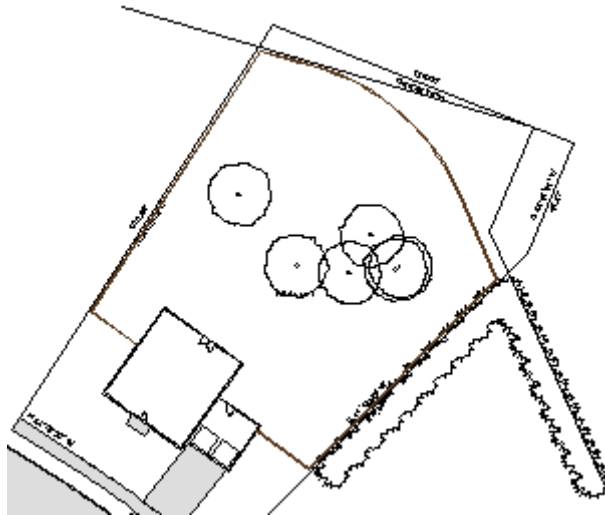

Creating a privacy fence from walls

You start the exercise by copying fence boundary geometry from the Base Plan layer, and then you paste it in place on the Beds layer.

1. If you did not complete Exercise 8—or you are unsure of your file's accuracy—open the **GS-VWLx08.vwx** file.
2. Press the X key, and then hold down the Shift key and select the property line and the two easement lines, shown at left. Press Ctrl+C to copy the objects. In the Navigation palette, activate the **03-Working-Beds** saved view, and then press Ctrl+Alt+V to paste the easement lines in place (shown at right).

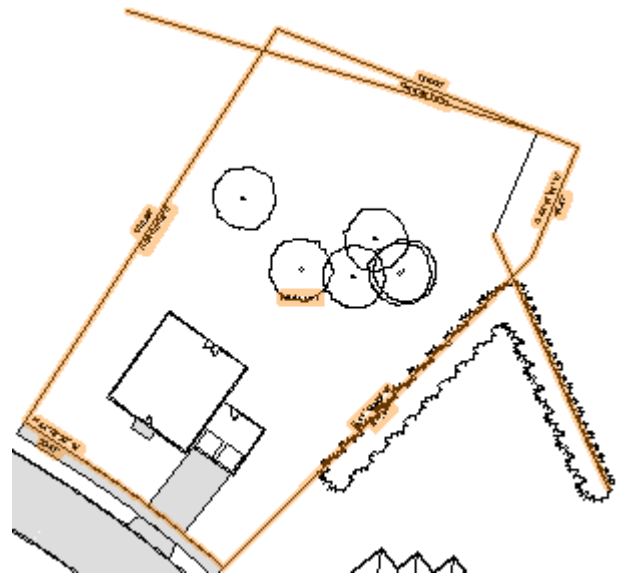
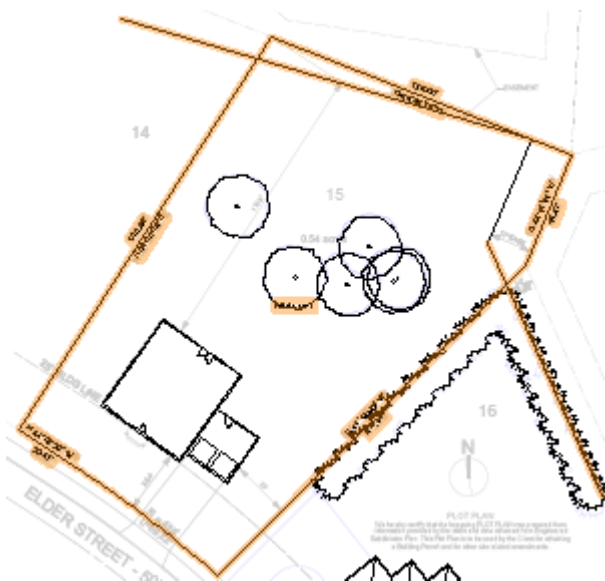

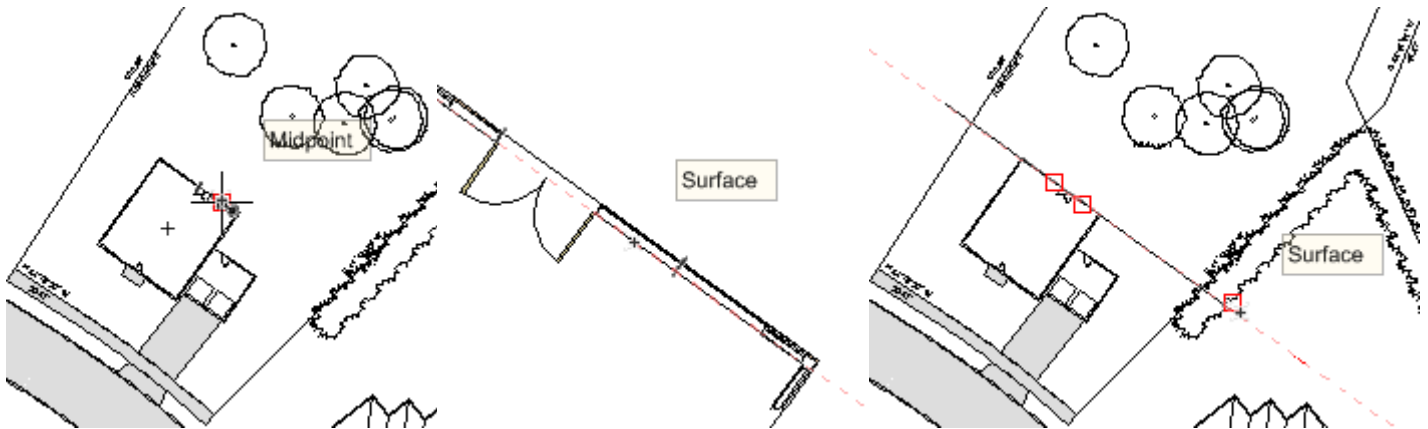

Next, you draw a line for the fence boundary at the house.

- Press the X key twice to clear the current selection. From the Basic tools palette, click the **Line** tool . Move your cursor over the house wall where shown at left, and then press the Z key to zoom in. Move the cursor over the house wall's inside edge (shown at center) and press the T key to set a surface snap. Draw a line by snapping to the surface line (outside the property line), as shown at right. In the Navigation palette, select the Design Layers tab, and then turn off visibility of the **Base Plan** and **Surfaces** layers.



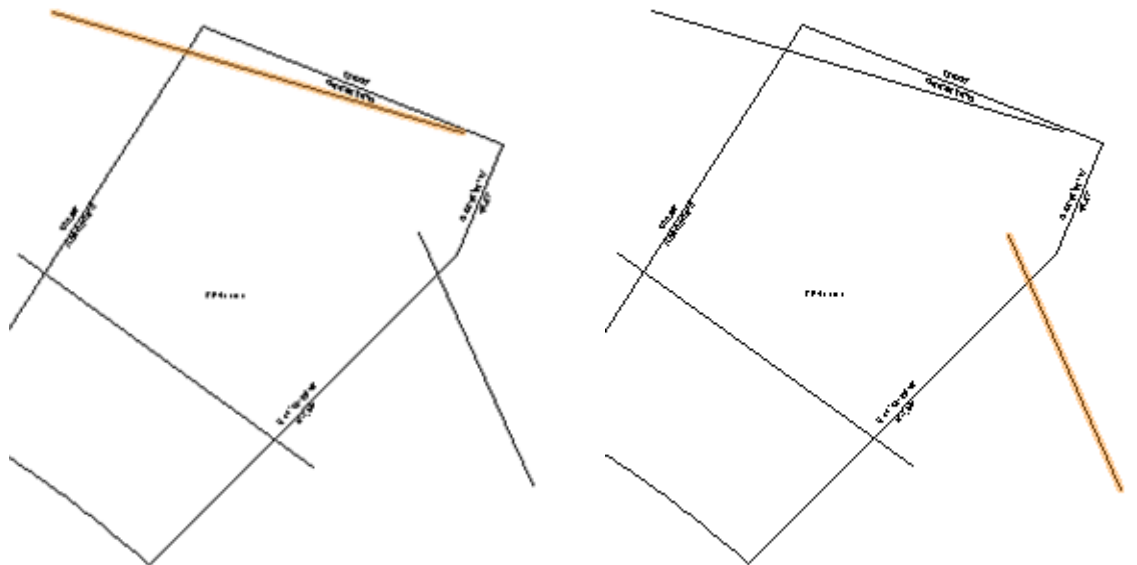
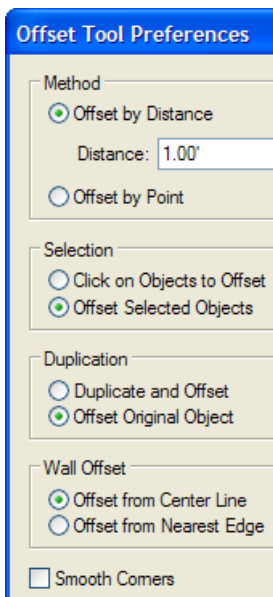

Next, you offset the easement lines, and then you create a fillet to connect them.

- Press the X key and select the long easement line. From the Basic tools palette, click the **Offset** tool . In the Tool bar, click **Preferences** . Adjust settings as shown at left, and then click **OK**. Click inside the line (near the middle of the boundary lines) to offset the line 1' [.305m], as shown at center. Keep holding down the Space bar for the Boomerang mode shortcut, press the X key once, and then select the short easement line. Release the Space bar, and then click 5 times to the left of the line to offset it a total of 5' [1.524m] from the original, as shown at right.



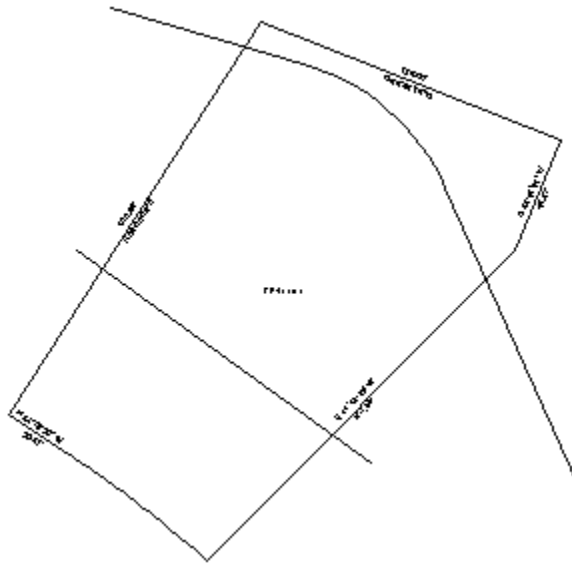

Note: Boomerang mode lets you adjust the display and perform other operations without exiting the active tool.

5. From the Basic tools palette, click the **Fillet** tool . In the Tool bar, enable **Fillet and Trim Mode**  (if it's not already active), and then click **Preferences**. In the Fillet Settings dialog box, change the Fillet Radius to 90.00' [27.432m], and then click **OK**. Click both easement lines to create the fillet and trim (and extend) both lines, as shown.



Next, you create a polygon from the boundary objects, and then you convert it to wall objects.

6. From the Basic tools palette, click the **2D Polygon** tool . Activate **Polygon From Inner Boundary Mode**  in the Tool bar. Click anywhere inside the boundary lines to create the polygon (fence perimeter), as shown.

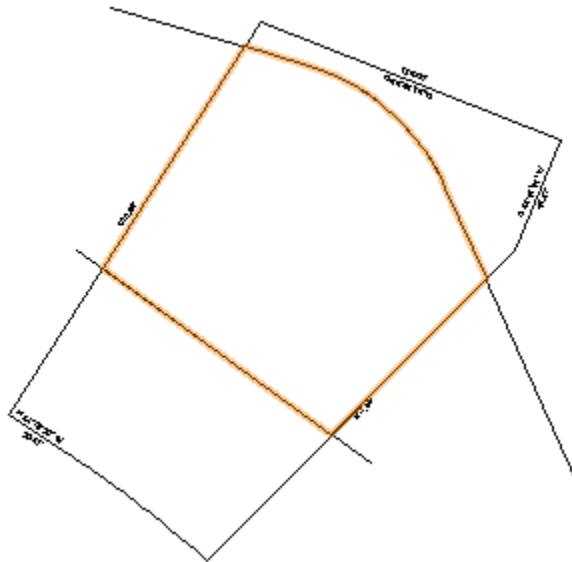

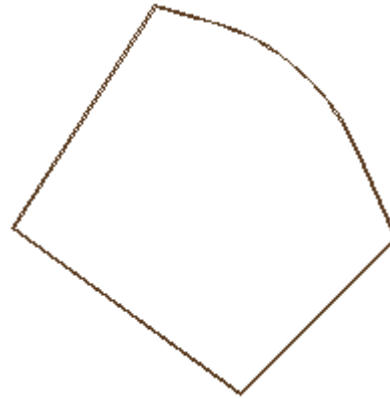
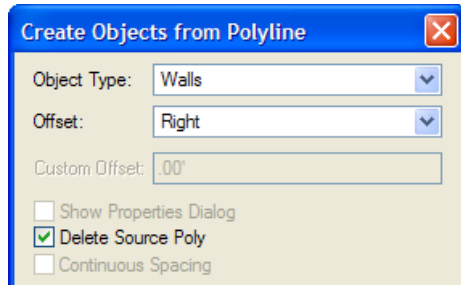

7. Press the X key to exit the **2D Polygon** tool, and then press Ctrl+A to select all six objects. Hold down the Shift key, and select the center of the polygon to deselect it (5 objects should now be selected). Press the Delete key to remove them from the drawing.

8. In the Resource Browser, scroll down and expand the Wall Styles section, and then double-click the **Wood Privacy Fence** wall style to activate it. Press the X key, and then select the polyline. From the menu, select **Modify > Convert > Objects from Polyline**. In the Create Objects from Polyline dialog box, adjust settings as shown at left (changing the Offset to **Right** creates walls inside the polyline), and then click **OK** to create the walls. Press the X key twice to clear the selection, and examine the walls, as shown at right.



Next, you use the **Wall Join** tool to connect the round wall segment with the adjacent straight segments.

9. From the Building Shell tool set, click the **Wall Join** tool . In the Tool bar, enable **L Join Mode**  (if it's not already active). Click wall segments in order, approximately where shown. The walls are joined, but their appearance does not change (see Note below figure).

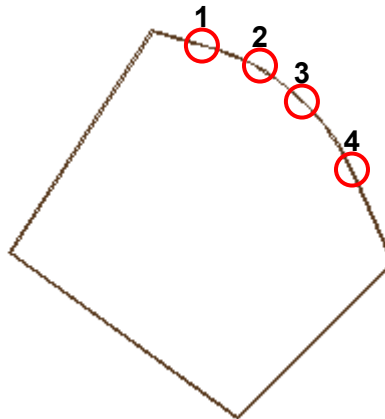

Notes:

- 1) Although these walls appear to be joined after the polygon conversion, you still need to join them so you can create polygons inside their boundaries later in [Exercise 14](#).
- 2) All corners where straight wall segments meet were already joined by the polygon conversion operation.



Next, you drag the wall objects to offset them.

Note: The next step works as described if you have Vectorworks Designer. If you don't have Vectorworks Designer or Vectorworks Architect, the **Enable Connected Walls Mode** option is not available. Start the step as instructed, and then after you press the X key, immediately start dragging the wall segment that touches the house towards the street. Press the Tab key once, and then enter 18' [5.486m] for the offset value and press Tab. Continue dragging the wall segment and release the mouse button when the Perpendicular/Length SmartCursor cue is displayed (the wall connection is not maintained). Use the same process with 1' [.305m] offset values for the east and west wall segments to offset them to the inside, and then use the **Wall Join** tool's **L Join Mode** option to join the corners that were disconnected by the dragging operations.

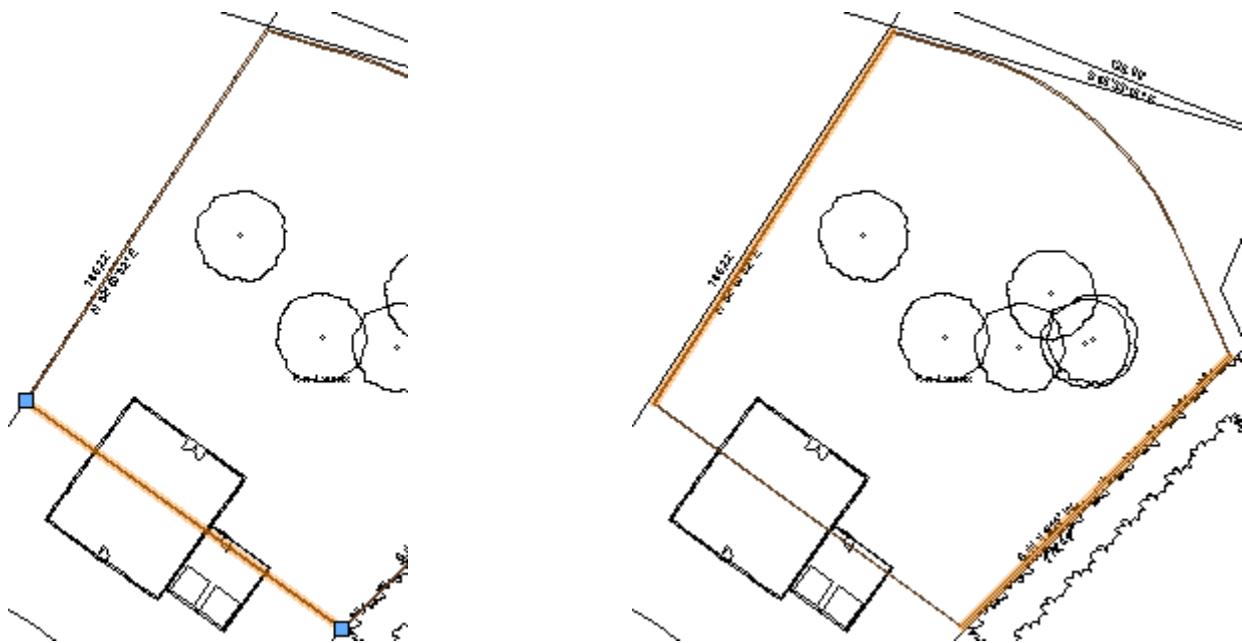
10. In the Navigation palette, turn on visibility of the **Base Plan** layer, and then zoom in on the fence. Press the X key, and then in the Tool bar, make sure **Enable Connected Walls Mode**  is active. Start dragging the wall segment that touches the house towards the street. Press the Tab key once, and enter 18' [5.486m] for the Offset value, and then press Enter twice to complete the offset, as shown at left. Notice that the wall connections are maintained after the offset operation. Repeat the process twice to offset the east and west wall segments 1' [.305m] to the inside (enter -1' [.305m] for the Offset value), as shown (highlighted for clarity) at right. Press the X key twice to clear the selection.



Next, you split the wall that intersects the house, and then you complete the fence by dragging the wall ends into position.

11. Select the wall segment that passes through the house, and then press Ctrl+6 to zoom in on it. From the Basic tools palette, click the **Split** tool . In the Tool bar, make sure **Line Split Mode**  is active. For the split line's start point, move your cursor over the garage door line, and press the T key to set a surface snap, shown at left. For the split line's start point, snap to the surface line on the inside of the fence wall (point 1), as shown at center. For the split line's end point, hold down the Alt key (to split only the active selection), and snap to the surface line outside the fence wall (point 2). Notice that the split wall's start point is now aligned with the garage door line, as shown at right.

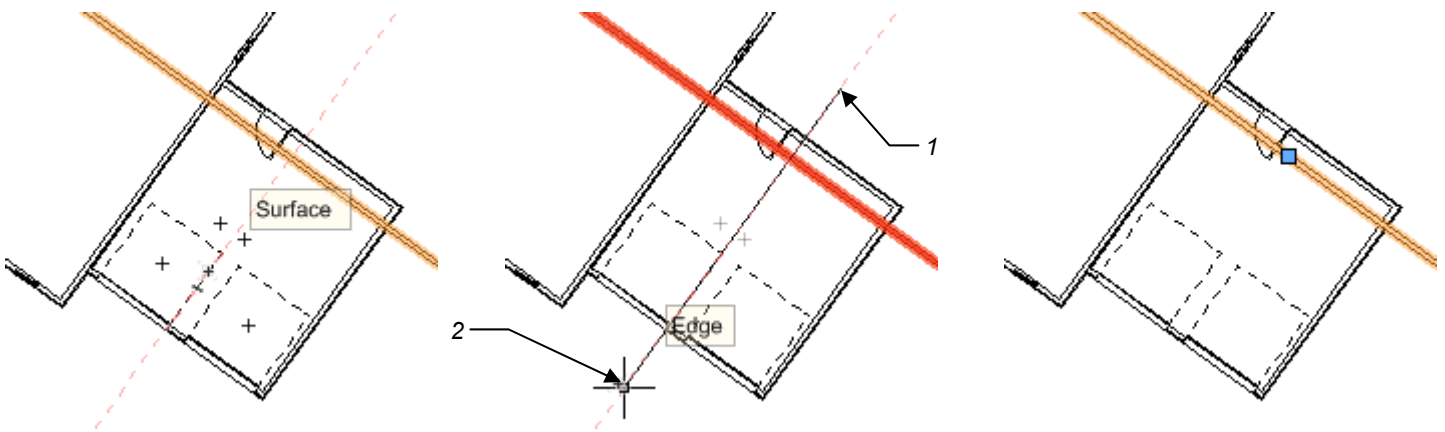

Next, you resize each split fence wall, so that they terminate just inside the house and garage exterior walls.

12. Zoom in on the house, and then press the X key and select the left split fence wall segment. Click the segment's right grip to pick it up, then move your cursor over the intersection of the highlighted wall segment and the house's left wall, and press the Z key to zoom in. Hold down the Shift key (to maintain the wall's current angle), and click in the middle of the wall, as shown at left. Repeat the process to resize the other split fence wall segment so it terminates in the middle of the garage's right wall to complete resizing operations, shown at right (with both segments highlighted for clarity – see Note below figure).

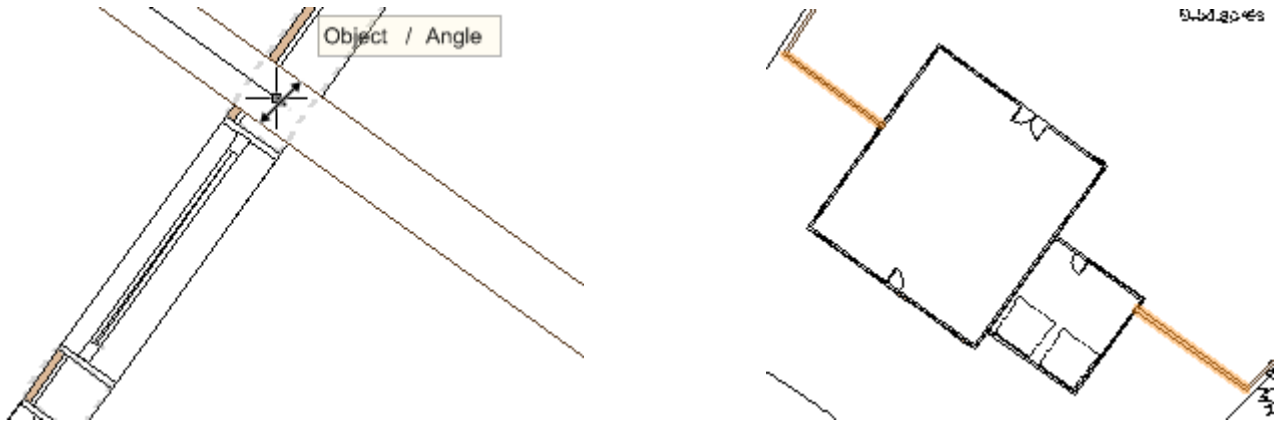

Note: To ensure proper operation of subsequent exercises, make sure the fence walls terminate inside the house and garage walls.

13. Press the X key twice to clear the selection. In the Navigation palette, activate the **03-Working-Beds** saved view, and examine the completed fence, as shown at right.

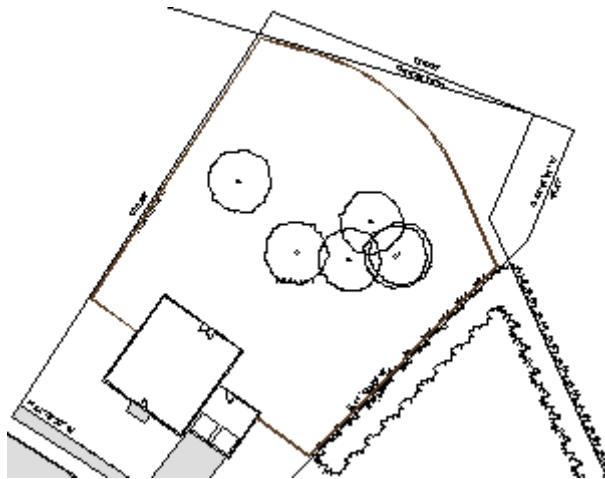

14. Save the file.

Exercise 10: Drawing the Pool

In this exercise, you draw construction geometry (for this exercise and subsequent exercises) to lay out the pool areas, and then you insert a pool symbol. You complete the exercise by drawing a pool deck and a pool house.

The completed exercise is shown in the following figure:

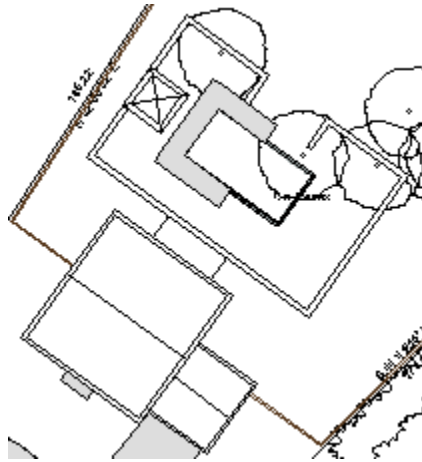

Laying out the pool area with construction geometry

You start the exercise by drawing and modifying rectangles, which you use as construction geometry for positioning the pool, creating the pool deck and pool house, the seat walls (in [Exercise 11](#)), hardscapes (in [Exercise 13](#)), and planting beds/turf areas (in [Exercise 14](#)). You begin by drawing the patio at the house's back door, and then you work your way out to the pool area.

1. If you did not complete Exercise 9—or you are unsure of your file's accuracy—open the **GS-VWLx09.vwx** file.
2. In the Navigation palette, activate the **04-Working-Surfaces** saved view, then activate the **Rotated Top** saved view. Select the Classes tab, then turn off visibility of the **Demolition** class. Zoom in on the rear door. From the Basic tools palette, double-click the **Rectangle** tool . In the Create Object dialog box, adjust settings (shown at left 20.00' [6.096m], 8.50' [2.591m]; ignore X, Y, Screen X, and Screen Y values through step 5), and then click **OK**. Hover the cursor over the rear door's insertion point, then move it over the exterior wall edge to find the intersection shown at center. Click to position the rectangle, and then press Ctrl+6 to see the patio rectangle, as shown at right.

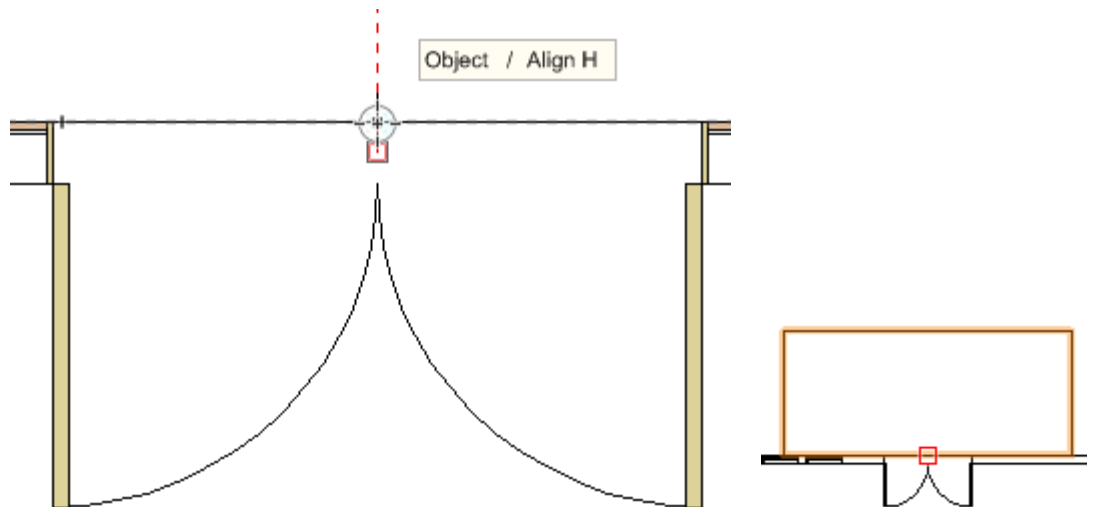
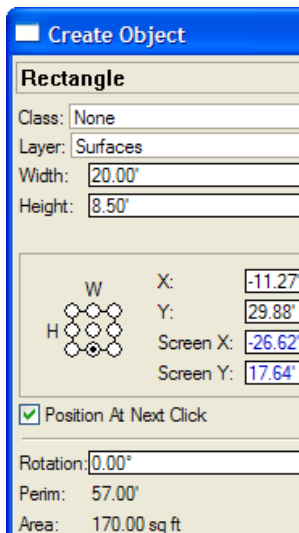

Next, you create a rectangle that represents the outer boundary of the pool area's seat walls.

3. Double-click the **Rectangle** tool , and then adjust settings (76.00' [23.165m], 48.00' [14.630m]) as shown at left. Click **OK**, and then snap the rectangle to the top center of the patio rectangle, and then press Ctrl+6 to see the seat wall boundary rectangle, as shown at right.

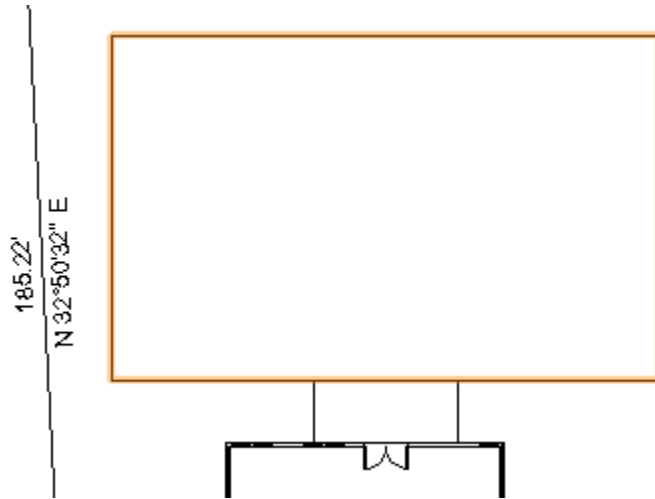
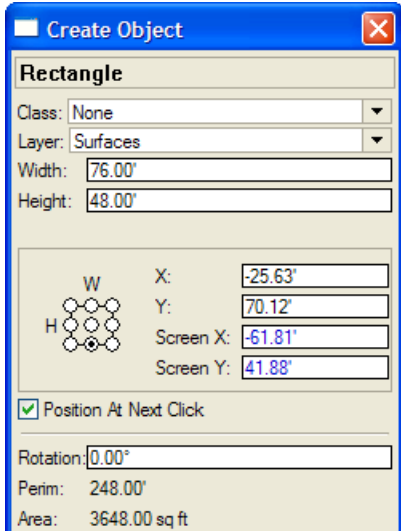

Next, you create a rectangle that represents the outer boundary of the pool deck.

4. Double-click the **Rectangle** tool , and then adjust settings (44.00' [13.411m], 28.00' [8.534m]) as shown at left. Click **OK**, and then snap the rectangle to the center of the seat wall boundary rectangle, as shown at right.

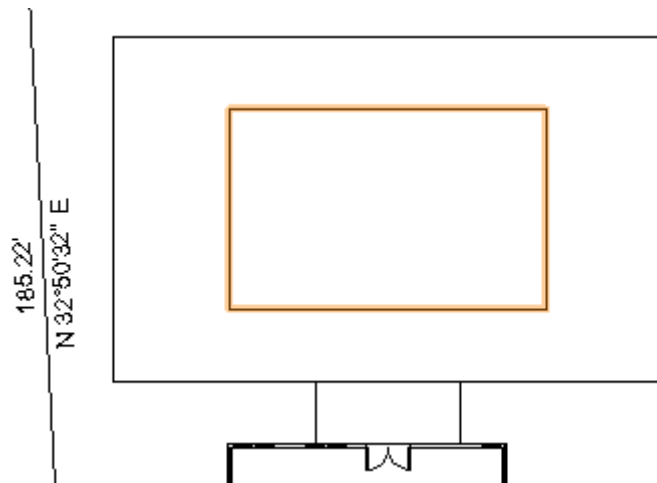
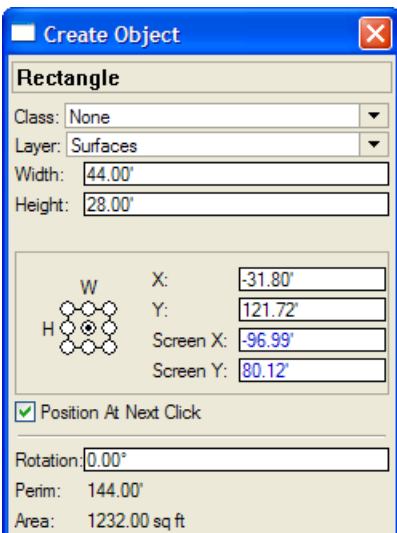

Next, you create a rectangle that represents the seat wall indentation that leads from the pool deck out to the back yard.

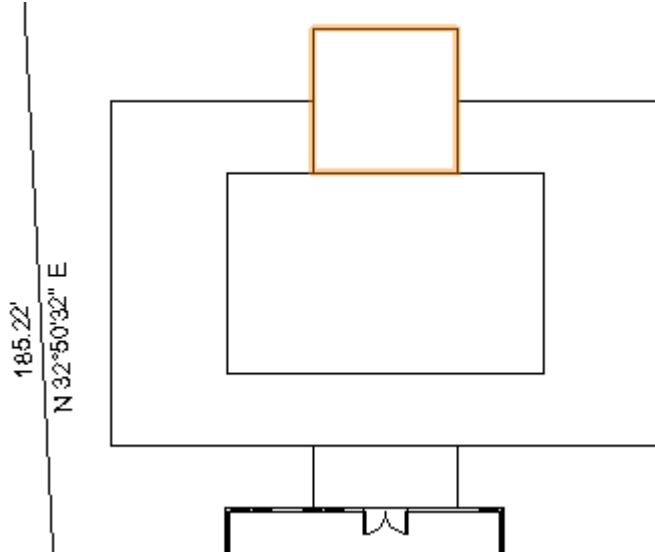
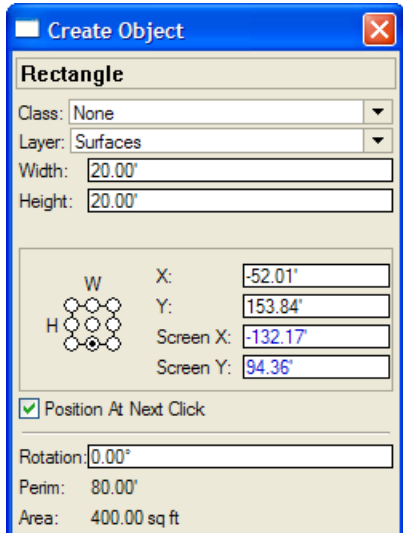

5. Double-click the **Rectangle** tool , and then adjust settings (20.00' [6.096m]) as shown at left. Click **OK**, and then snap the rectangle to the top center of the pool deck boundary rectangle, as shown at right (leave the rectangle selected for the next step).

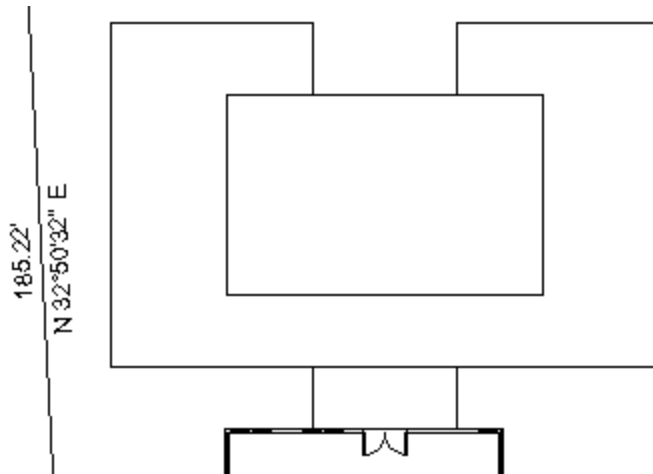

Next, you use the **Clip Surfaces** command, and the **Offset tool** to complete the construction geometry.

6. Press the X key, and then hold down the Shift key and select the seat wall boundary rectangle (2 rectangles should now be selected). Right-click the selection, and then select **Clip Surface** from the Context menu. Press the Delete key to remove the clipping rectangle from the drawing, and examine the clipped seat wall boundary polygon, as shown.



7. Select the clipped seat wall boundary polygon. From the Basic tools palette, click the **Offset** tool . In the Tool bar, click **Preferences** . Adjust settings (18.5" [.470m]) as shown at left, and then click **OK**. Click inside the line—near the middle of the boundary lines—to offset the line 18.5 inches [.470m], as shown at right (leave the offset polygon selected for the next step).

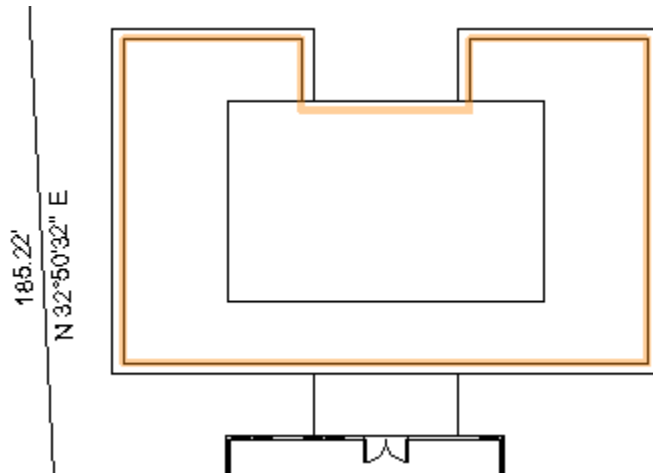
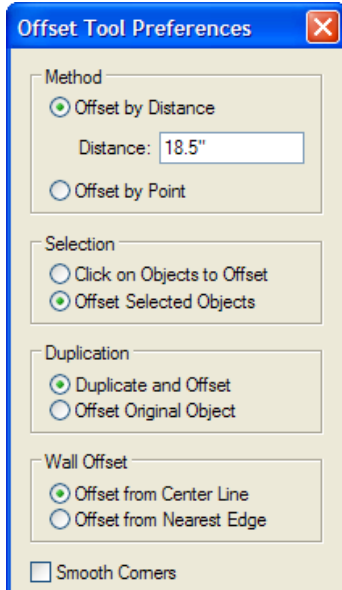

8. Press the X key, and then hold down the Shift key and select the outer seat wall boundary polygon (2 polygons should now be selected). Right-click the selection, and then select **Clip Surface** from the Context menu. Press the Delete key to remove the clipping polygon from the drawing, and examine the clipped seat wall boundary polygon, as shown at left. Hold down the Shift key and select the seat wall boundary polygon and the pool deck boundary rectangle (2 objects should now be selected). Right-click the selection, and then select **Clip Surface** from the Context menu (do not delete the pool deck boundary rectangle). Select the seat wall boundary polygon, and notice that it no longer intersects the pool deck boundary rectangle, and examine the completed construction geometry, as shown at right.

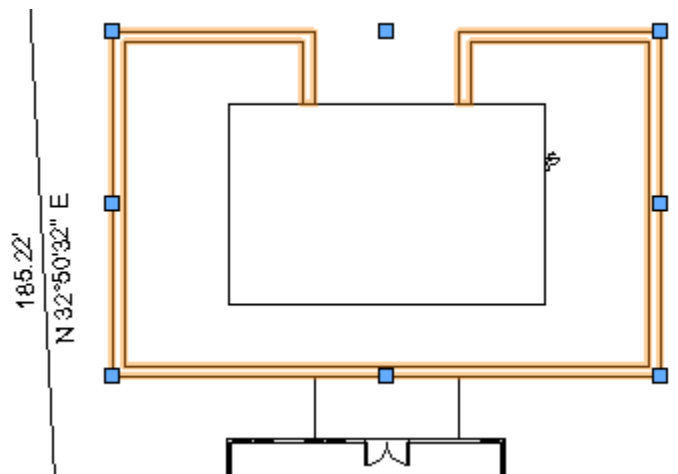
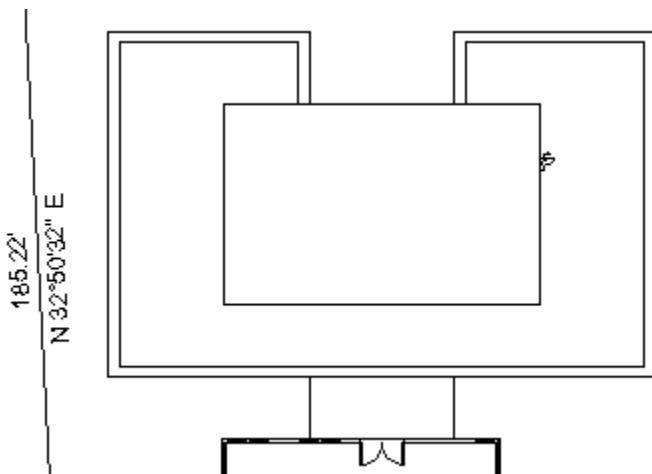

Note: You could create all of the features in this exercise—and subsequent exercises—without construction geometry, but you use construction geometry in this tutorial to ensure layout accuracy, provide clearly defined snap points (where the alternative would be snapping to objects with excessive snap points from overlapping geometry), and create collinear boundaries for polygon fill operations. You may also find this technique indispensable in your own designs for the same reasons.

Inserting the pool symbol

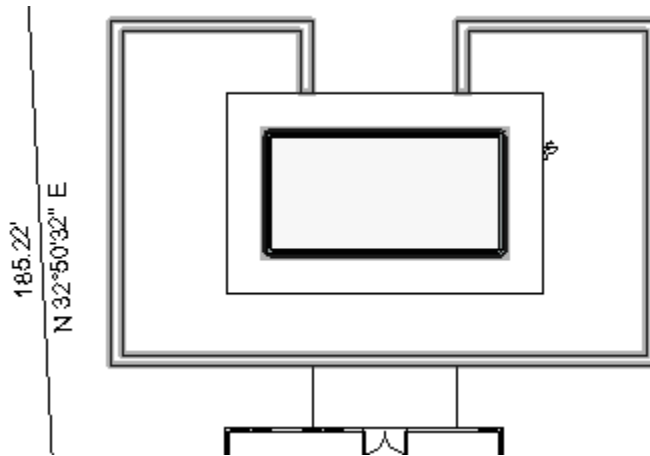

Next, you insert the pool symbol from the Resource Browser.

- Press the X key twice to clear the selection. In the Resource Browser, scroll down and double-click the **Pool** symbol. Double-click the center of the pool deck boundary rectangle to insert the pool symbol. Press the X key to exit the **2D Symbol Insertion** tool, and then in the Object Info palette, change the Pool symbol's Class to **Water Feature**. Hold down the Shift key and select the seat wall boundary polygon (two objects should now be selected). From the menu, select **Modify > Lock** to fix the objects' position, as shown. Press the X key twice to clear the selection.



Drawing the pool deck

Next, you create the left half of the pool deck using a pathway hardscape object.

- From the Site Planning tool set, click the **Hardscape** tool , click **Preferences** , then change the Configuration settings (shown at left; 6.00' [1.829m], 3.00' [.914m]), and click **OK**. Click the bottom center of the pool deck boundary rectangle, then click the bottom left corner, top left corner, and then double-click the top center point to create the hardscape object, as shown (leave it selected for the next step).

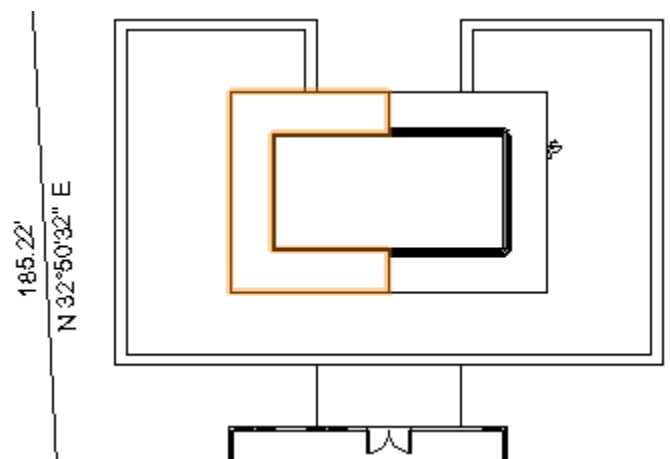
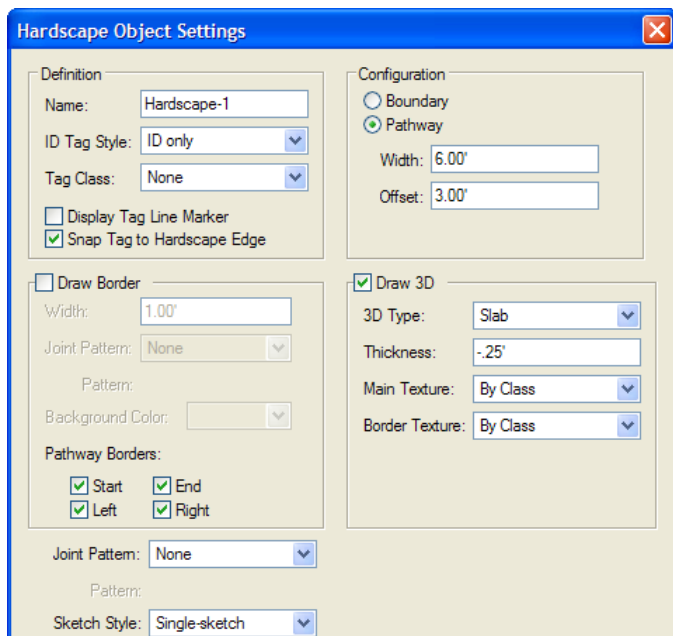

11. In the Object Info palette, change the Class and Hardscape Name, as shown at left. Press the X key, and select the pool deck boundary rectangle, and then press the Delete key to remove it from the drawing. Examine the completed pool deck hardscape object, as shown at right.

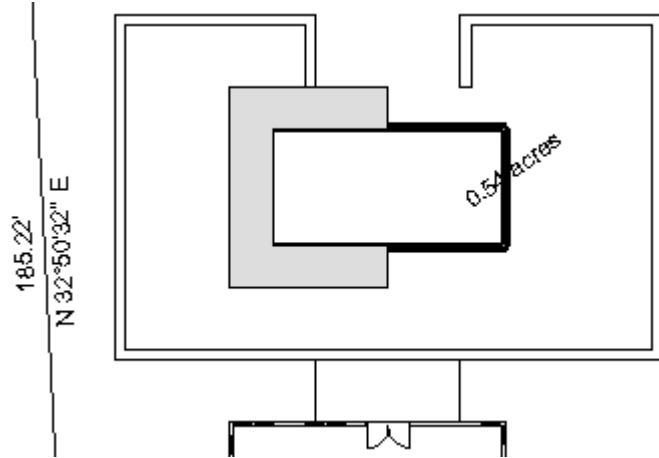
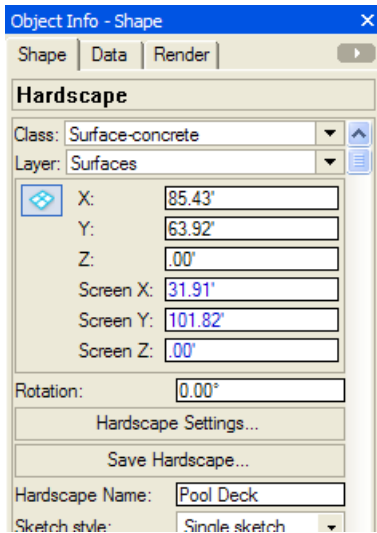

Drawing the pool house walls

Next, you draw a rectangle, and then you convert it to walls for the pool house.

12. Double-click the **Rectangle** tool , and then adjust settings (10.00' [3.048m]) as shown at left. Click **OK**, then snap the rectangle to the inside left midpoint of the center of the seat wall boundary polygon, and then press the X key twice to clear the selection, as shown at right.

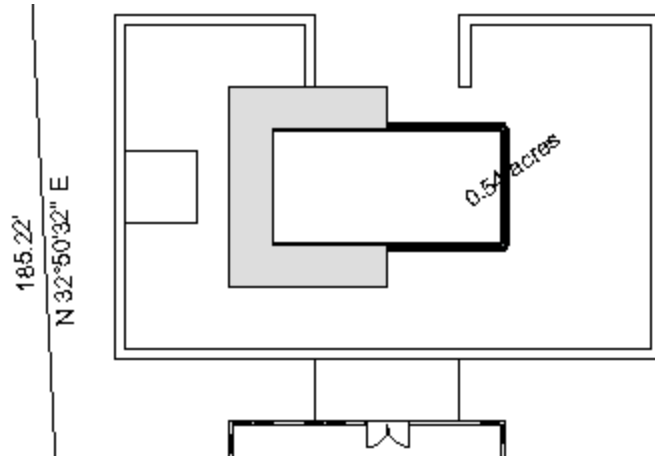
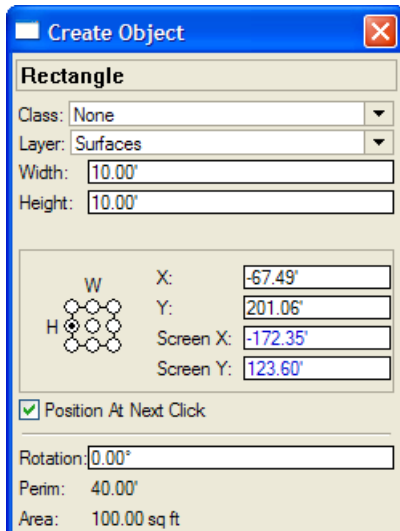

13. In the Resource Browser, double-click the **Ext-Siding-Framing** wall style to activate it. Press the X key and select the pool house rectangle. From the menu, select **Modify > Convert > Objects from Polyline**. In the Create Objects from Polyline dialog box, adjust settings as shown at left (make sure the **Delete Source Poly** option is disabled), and then click **OK** to create the walls, as shown at right (leave the walls selected for the next).

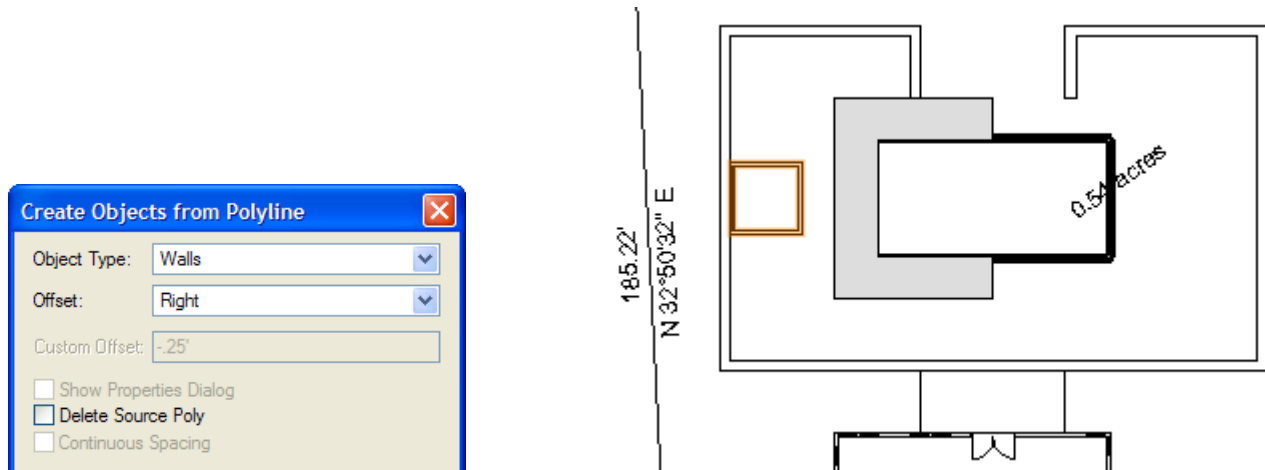

14. In the Object Info palette, change the selected walls' Layer to **Architecture** (the walls disappear, and No Selection is displayed in the Object Info palette). In the Navigation palette, activate the **02-Working-Architecture** saved view. Notice the walls are now visible, as shown.

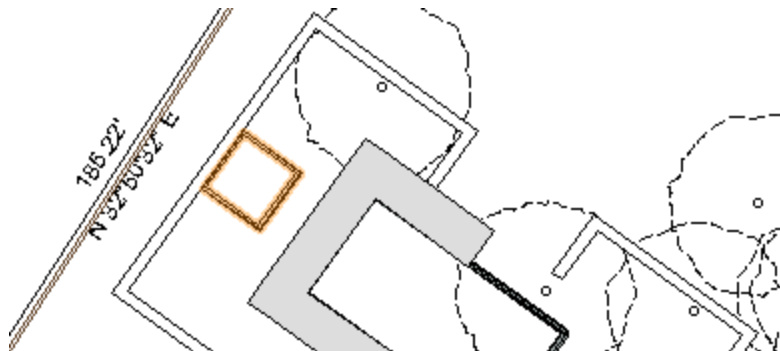

Note: Visibility of the Base Plan layer and Demolition class are on by default in all saved "working" views except the 08-Working-Scan saved view. This is intentional for the design phase so you can see all aspects of the site as you develop your design. In your own designs, you can adjust visibility accordingly for all saved views, after the design is complete.

Next, you insert a door in the pool-side wall.

15. From the Building Shell tool set, click the **Door** tool . Click the midpoint of the pool-side wall and insert the door, oriented as shown.

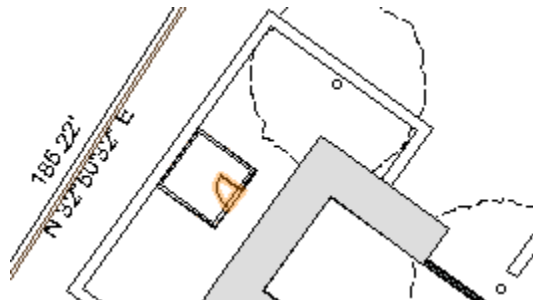

Drawing the pool house roof

Next, you create a roof from the pool house walls.

16. Press the X key twice, and then hold down the Shift key and select all four pool house walls. From the menu, select **Landmark > AEC > Create Roof**. In the Create Roof dialog box, change settings (.53' [.162m], .46' [.140m], 10.00' [3.048m], 1.50' [.457m]) as shown at left. Click **OK** to create the roof, and then press Ctrl+5 to adjust the display. In the View bar, notice that the Upperstory layer is now active (so you can see the roof), as shown at right. Press the X key twice to clear the selection.

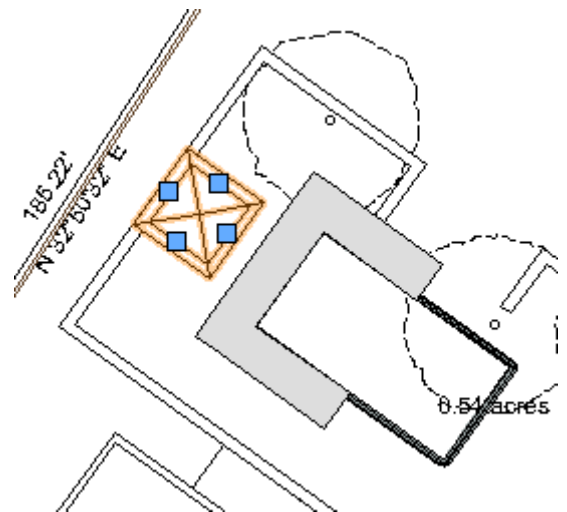
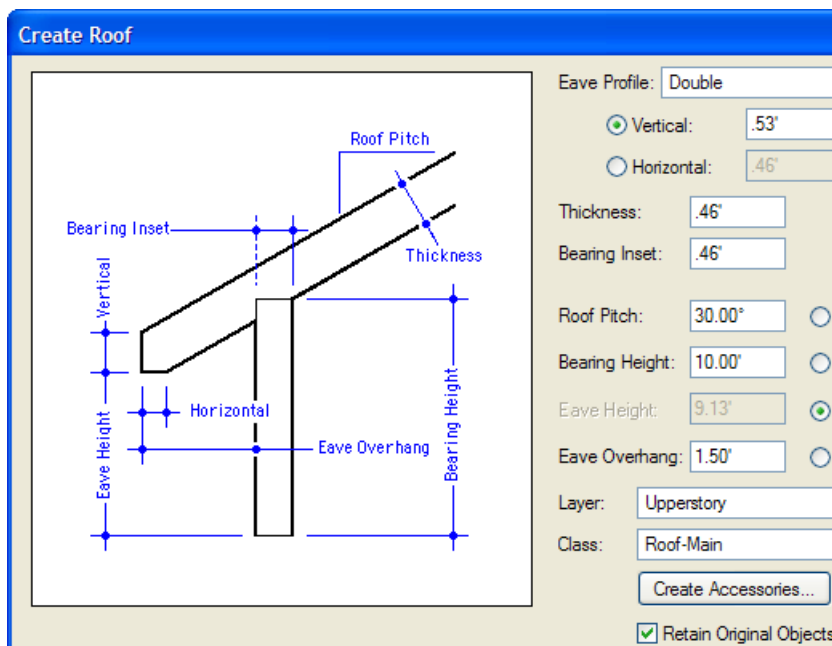

17. Save the file.

Exercise 11: Drawing Seat Walls

In this short exercise, you create a seat wall with the **Wall** tool, and then you create a roof object for the seat wall cap.

The completed exercise is shown in the following figure:

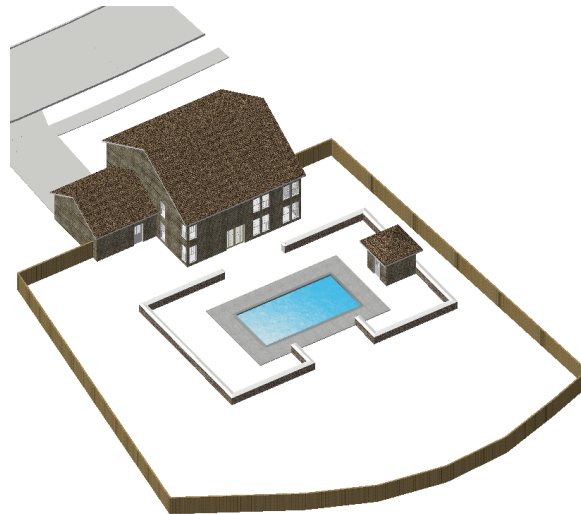

Drawing the seat wall

You start the exercise by drawing half of the seat wall.

1. If you did not complete Exercise 10—or you are unsure of your file's accuracy—open the **GS-VWLx10.vwx** file.
2. In the Navigation palette:
 - Activate the **02-Working-Architecture** saved view
 - Activate the **Rotated Top** saved view
 - Select the Design Layers tab, and then turn off visibility of the **Base Plan** layer
3. In the Resource Browser, scroll down and expand the Wall Styles section, and then double-click the **Seat Wall** wall style to activate the **Wall** tool. Start with the top left corner of the patio rectangle, and then continue clicking construction vertices in clockwise order (double-click the last vertex) to create the left side seat walls, as shown (leave the walls selected for the next step).

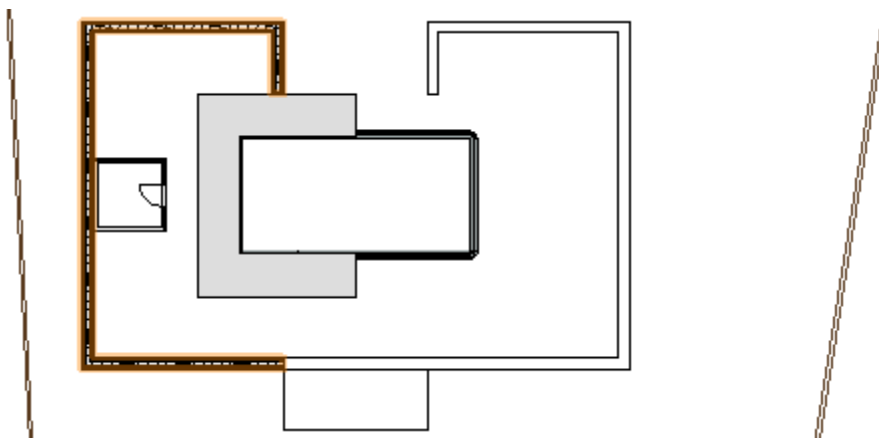

Drawing the seat wall cap

Next, you create a roof object from the seat walls, and then you change its properties for use as a seat wall cap.

4. With the seat walls still selected, select **Landmark > AEC > Create Roof** from the menu. Adjust settings (1" [25.40mm], 2'8" [.813m], 1.5" [38.10mm]) as shown at left, and then click **OK** to create the roof. Press the X key twice, and examine the roof (seat wall cap), as shown at right.

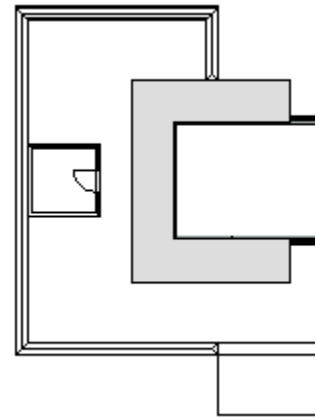
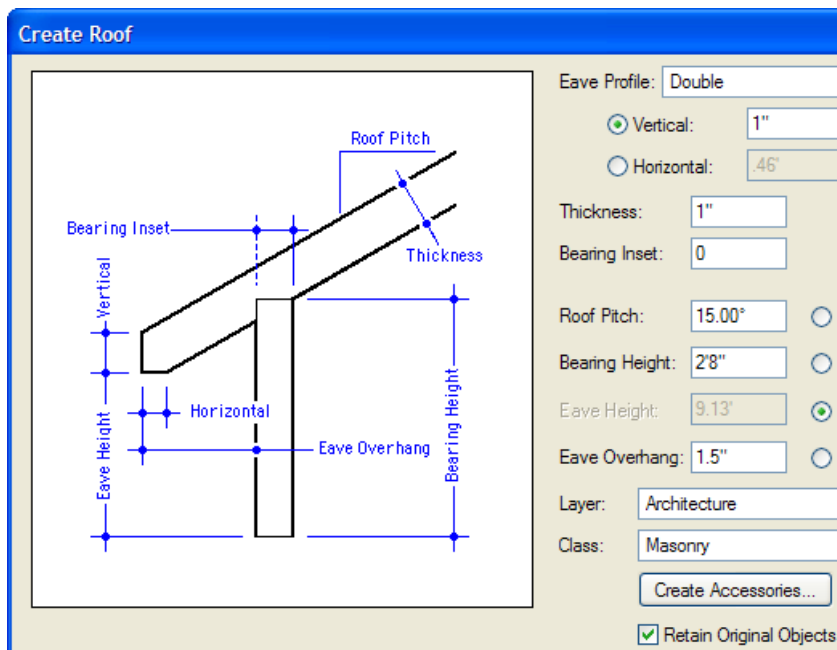



Note: To save time, you skip the process of notching the roof object to eliminate the interference with the pool house wall.

Mirroring objects

Next, you adjust layer option and class visibilities, and then you use the **Mirror** tool to complete the decking and seat walls on the opposite side of the pool.

5. Press **Ctrl+Alt+L** to toggle off **Stack Layers** viewing mode. In the Navigation palette:
 - Select **Show/Snap/Modify Others** from the Layer Options drop down list.
 - Select the **Classes** tab, and then turn off visibility of the **Building** class.

Warning: Use caution when the **Show/Snap/Modify Others** layer option is active. You should only use this option temporarily (do not enable this option in your saved views) until you become more comfortable using Vectorworks Landmark.

6. Draw a marquee (shown at left) to select the seven objects on the left side of the pool. Hold down the Shift key, and then select the pool house rectangle to remove it from the current selection (6 objects should now be selected). From the Basic tools palette, click the **Mirror** tool . In the Tool bar, enable **Duplicate and Mirror Mode**  (if it's not already active). Snap to top right and bottom right endpoints of the pool deck hardscape object to specify the mirror line and duplicate the objects. Press the X key twice to clear the selection, and examine the mirrored copies, shown at right.

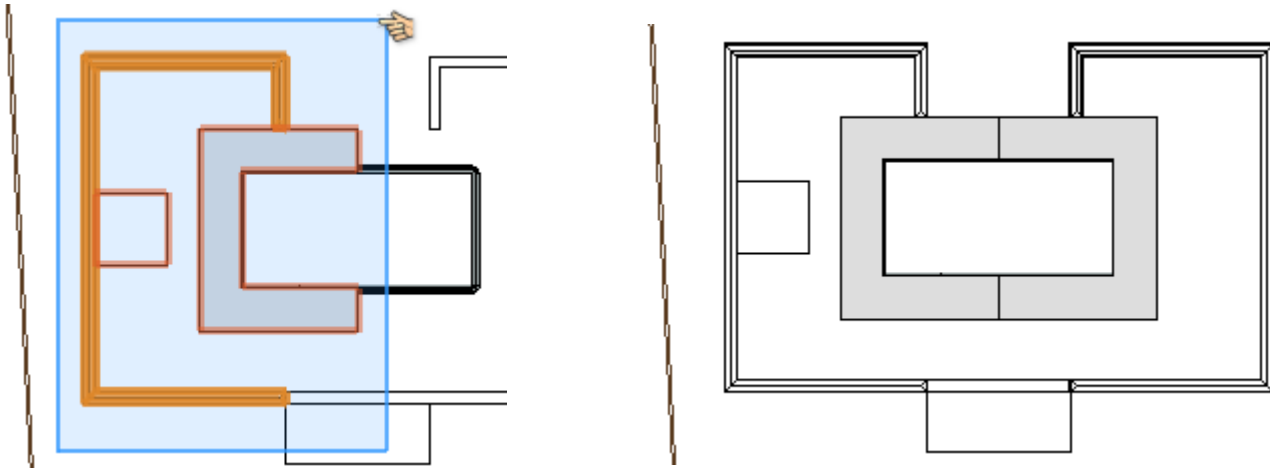

7. Hold down the shift key and select both pool deck hardscape objects. Right-click the selection and select **Send > Send to Back** to correct the stacking order, and then clear the selection, as shown at left. In the Navigation palette, activate the **Iso-Without Plants** saved view (you may need to activate it twice), and examine the landscaping design, as shown.

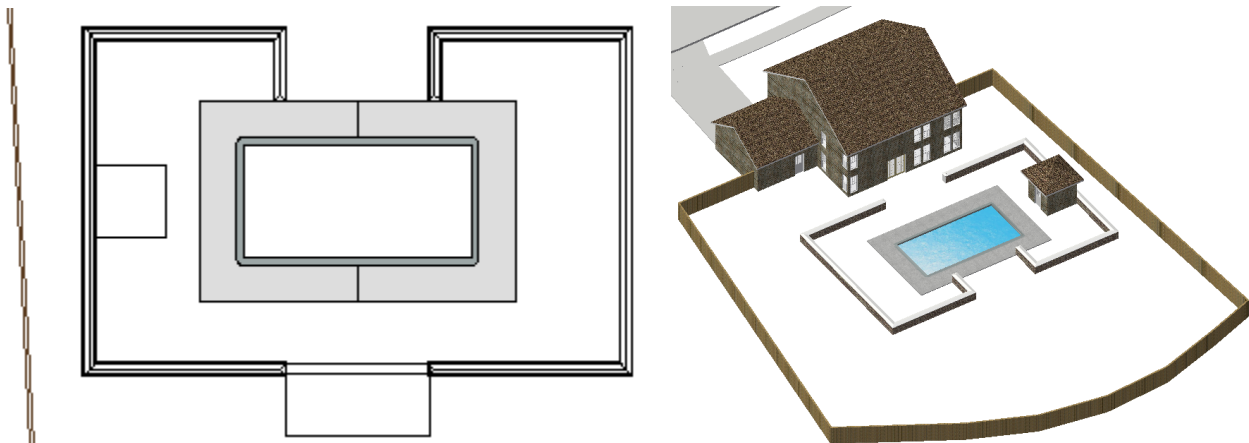

*Tip: The **Iso-Without Plants** saved view is set up for visualizing only planting bed/turf areas, hardscapes, and constructed elements. Use the **Iso-Full** saved view at any time in the design process to visualize all aspects of the landscape design for planning purposes or informal client design reviews.*

8. Save the file.

Exercise 12: Inserting Symbols

In this exercise, you enhance the landscape design by inserting pre-configured hybrid symbols from the Resource Browser.

The completed exercise is shown in the following figure:



Inserting the pergola symbol

You start the exercise by inserting the pergola symbol from the Resource Browser, and then you align it with the seat wall cap.

1. If you did not complete Exercise 11—or you are unsure of your file's accuracy—open the **GS-VWLx11.vwx** file.
2. In the Navigation palette, activate the **02-Working-Architecture** saved view (you may need to activate it twice), then activate the **Rotated Top** saved view. Select the classes tab, and turn off visibility of the **Demolition** class. Right-click the seat wall cap on the right side of the pool (the roof object you just mirrored) and select **Lock** from the context menu to fix its location, as shown.

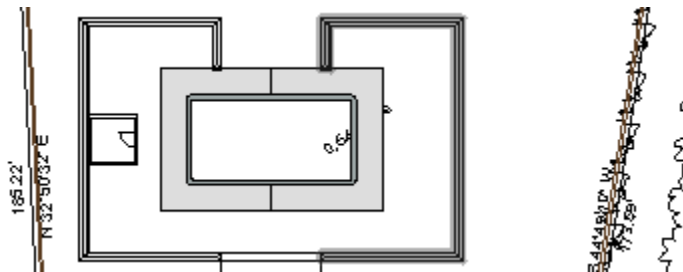

3. In the Resource Browser, scroll down and open the Symbols/Plug-In Objects folder (if it's not open already). Scroll down the list and double-click the **Pergola** symbol. In the Basic tools palette, notice that the **2D Symbol Insertion** tool  is now active. Double-click approximately where shown to insert the Pergola symbol.

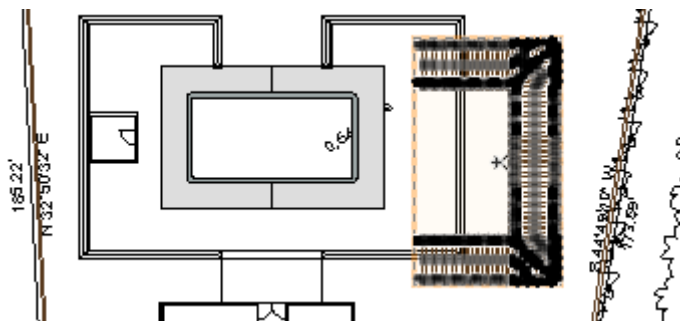

4. Press the X key once to cancel the **2D Symbol Insertion** tool and then hold down the Shift key and select the locked seat wall cap to add it to the current selection. From the menu, select **Modify > Align > Align/Distribute**. In the Align/Distribute Objects dialog box, adjust settings as shown at left, and then click **OK** to align the pergola with the locked seat wall cap, as shown at right.

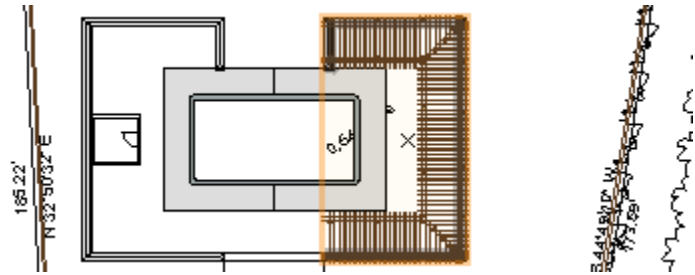
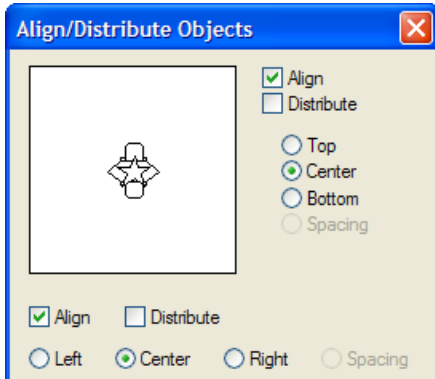

5. Press the X key twice to clear the selection, and then select only the pergola symbol. In the Object Info palette, change the Layer to **Upperstory** (the pergola disappears because the Upperstory layer is invisible). In the Navigation palette, activate the **01-Working-Upperstory** saved view, then press Ctrl+6 to zoom in. Clear the selection again to see the completed pergola (in the correct stacking order), as shown.

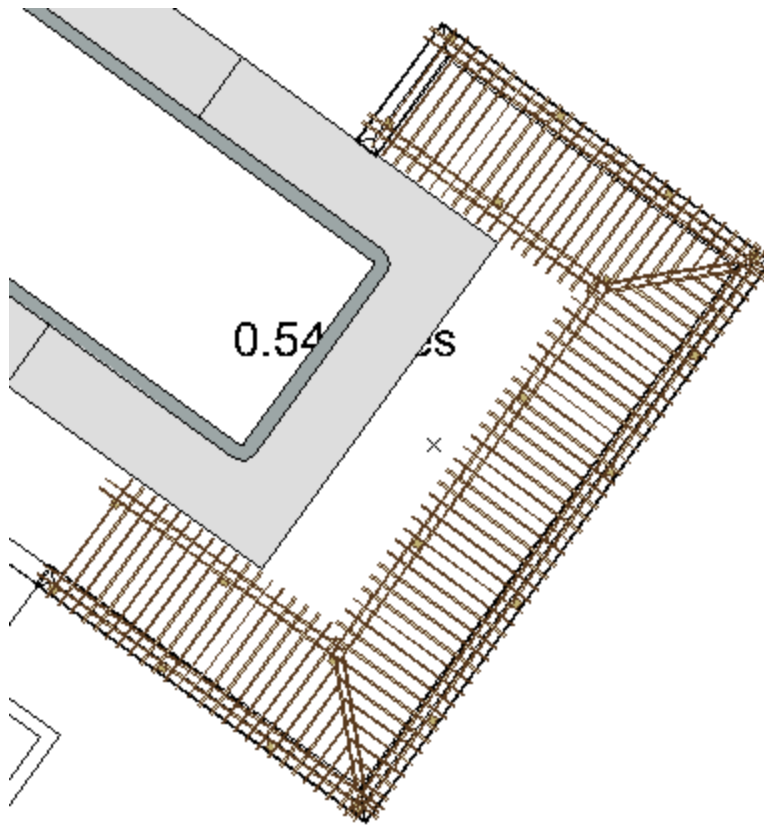

Inserting the gazebo symbol

Next, you insert the gazebo symbol—the focal point of the landscaping design—along the pool's centerline.

6. In the Navigation palette, activate the **02-Working-Architecture** saved view, and then activate the **Rotated Top** saved view. In the Resource Browser, double-click the **Gazebo** symbol, and insert one instance by double-clicking the outside endpoint where the pool deck hardscapes meet, as shown (leave the gazebo symbol selected for the next step).

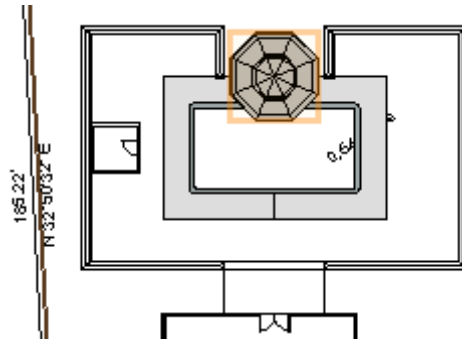

Now that the gazebo is aligned with the pool's centerline, you use the **Move** command to precisely position it near the rear fence.

7. From the menu, select **Modify > Move > Move**. In the Move dialog box, change the settings (59.00' [17.983m]), as shown at left. Click **OK** to move the gazebo close to the fence, as shown at right (leave the gazebo symbol selected for the next step).

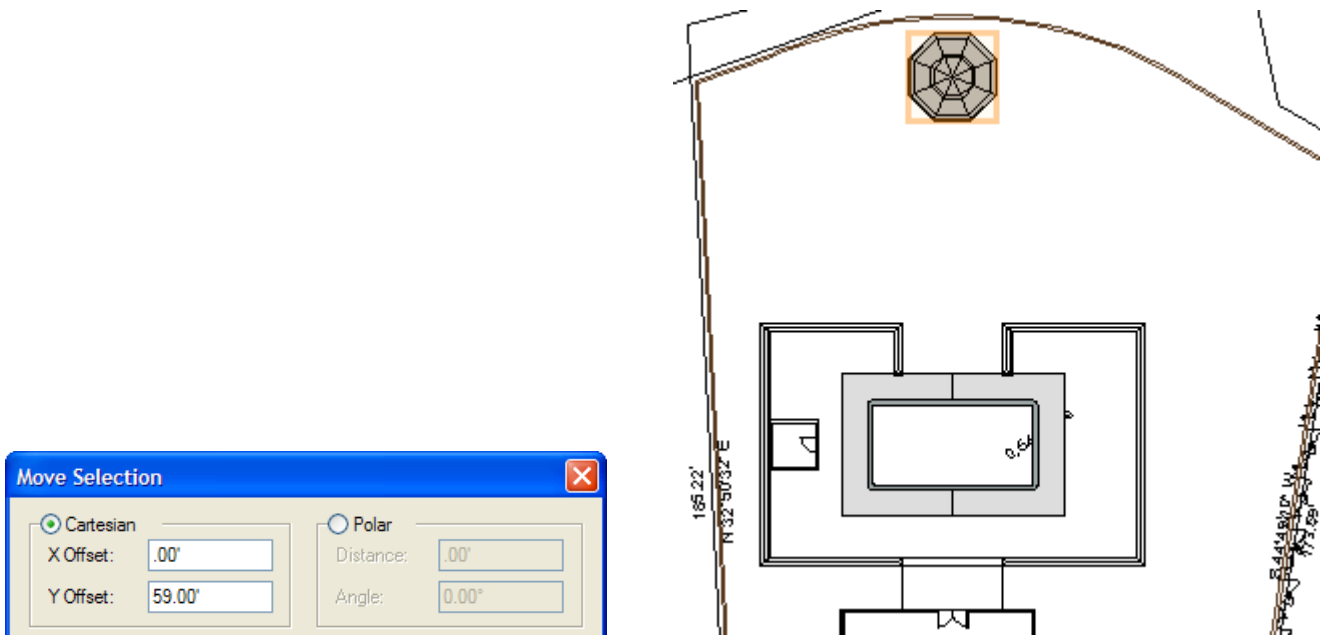

Note: You could alternately dynamically position the gazebo symbol by dragging it while holding down the **Shift** key to maintain vertical alignment. Instead, you use the **Move** command in this exercise to ensure that the gazebo is positioned accurately for proper operation of subsequent exercises.



Inserting the bench symbol

Next, you insert curved bench symbol inside the gazebo, and then you duplicate it to create a circular array of three benches.

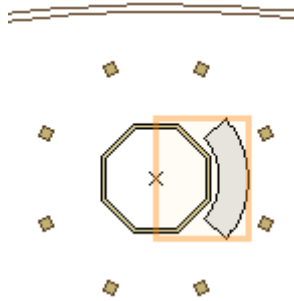
8. Press Ctrl+6 to zoom in on the gazebo symbol, and then press the X key twice to clear the display. In the Navigation palette:
 - Select the Design Layers tab, and then activate the **Beds** layer
 - Select the Classes tab, and then turn off visibility of the **Roof-Main** class
9. In the Resource Browser, double-click the **Curved Stone Bench** symbol, and insert one instance of the symbol by double-clicking the insertion point of the gazebo, as shown (leave the new symbol selected for the next step).



Next, you activate the **3D Selection** tool to activate a 3D view so you can change the Z value of the curved bench symbol (so it sits on top of the gazebo floor), and then you create a circular array.

10. From the Basic tools palette, click the **3D Selection** tool  (do not select any objects). Notice that the view changes to 3D, as shown. Also notice that the Z value is now displayed in the Object Info palette. Change the Z value to 8.75" (inches) [222.25mm], and then press Enter. In the View bar, click **Previous View**  once to revert the rotated top view (leave the bench symbol selected for the next step).

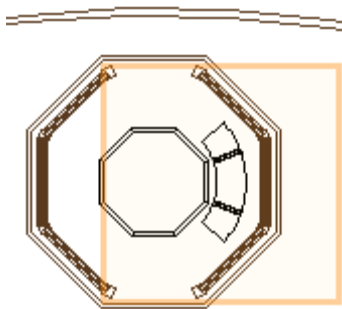

Note: You activate the **3D Selection** tool to switch to a 3D view (instead of activating the **Top** standard 3D view). You do this because when you activate the **Top** standard 3D view, the view rotation reverts to 0 (zero).

11. From the menu, select **Edit > Duplicate Array**. In the Duplicate array dialog box, adjust settings, as shown at left. Click **OK**, and then click the insertion point to create the circular array, as shown at right.

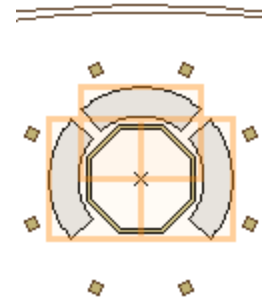
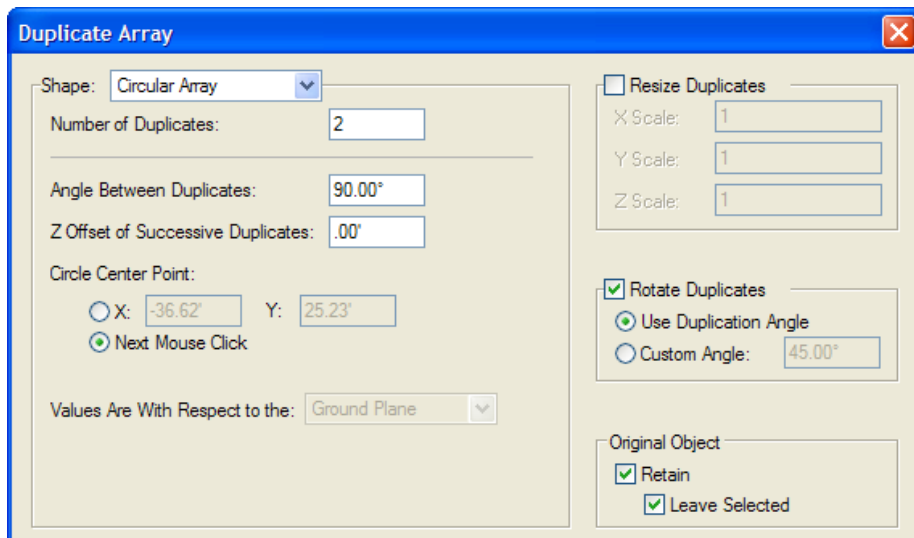

12. In the Navigation palette, turn on visibility of the **Roof-Main** class. Notice that the gazebo roof obscures the selected bench symbols, as shown at left. Press the X key twice to clear the selection, and then activate the **Iso-Without Plants** saved view (you may need to activate it twice). Examine the new symbols in the landscaping design, as shown at right.

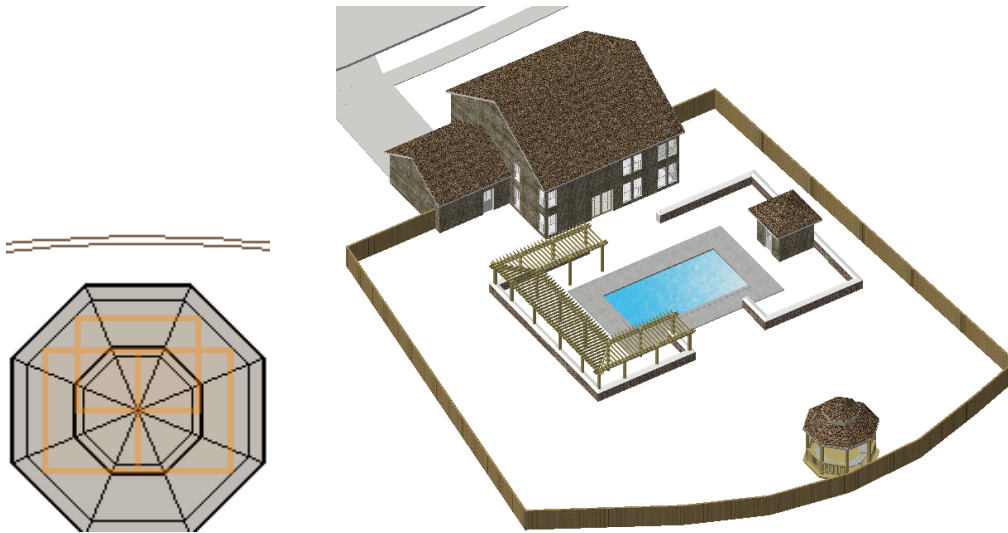

13. Save the file.

Section 4: Setting up Landscape Areas

In two exercises, this section covers the following processes in the landscape design project:

- Drawing boundary hardscapes (pg 67)
- Drawing pathway hardscapes (pg 69)
- Duplicating a hardscape object along a path (pg 71)
- Creating a duplicate array from a hardscape object (pg 72)
- Drawing the planting bed areas (pg 73)
- Filling in the turf areas (pg 76)

In these exercises, you start vertically building the landscape design, literally from the ground up. You use different methods to draw hardscapes, and then you draw a curved planting bed boundary line. You then use existing objects (on different design layers) to automatically generate planting bed and turf areas.

Exercise 13: Drawing Hardscapes

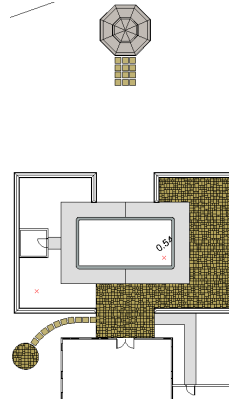

In this exercise, you complete the remaining paved areas in the landscape design by creating boundary and pathway hardscape objects, and duplicating a stepstone hardscape object.

The completed exercise is shown in the following figure:



Drawing boundary hardscapes

You start the exercise by resizing the patio construction rectangle, and then you create the paved pool area hardscape.

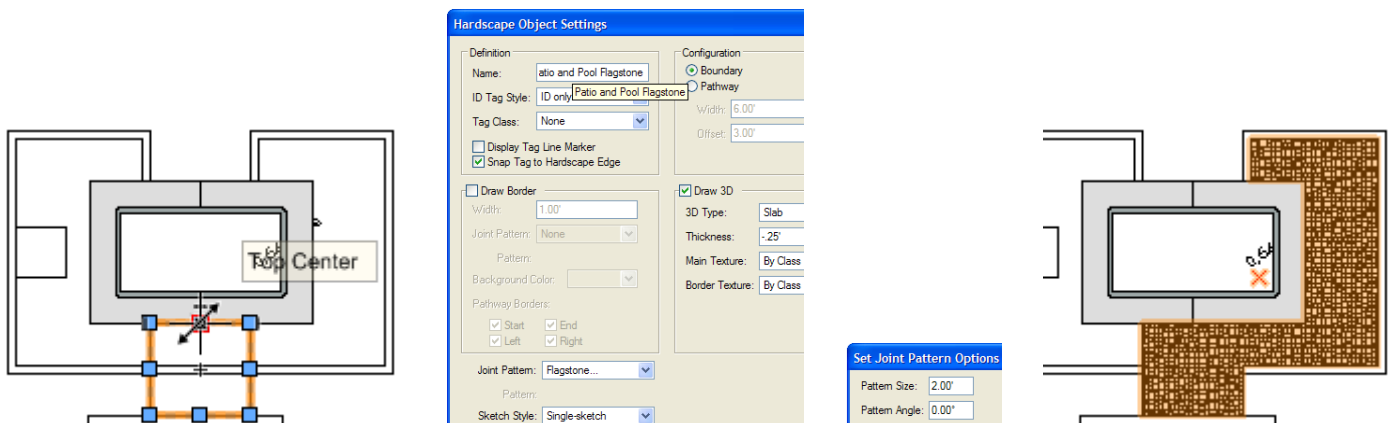

1. If you did not complete Exercise 12—or you are unsure of your file’s accuracy—open the **GS-VWLx12.vwx** file.
2. In the Navigation palette:
 - Activate the **04-Working-Surfaces** saved view (you may need to activate it twice).
 - Activate the **Rotated Top** saved view.
 - Select the classes tab, and then turn off visibility of the **Building** and **Demolition** classes.
3. Zoom in on the seat wall area. Press the X key, and select the patio construction rectangle, then resize it by clicking its top center grip, and then snapping to the outside endpoint where the pool deck hardscapes meet, as shown at left. Press the X key twice to clear the selection. From the Site Planning tool set, click the **Hardscape** tool . In the Tool bar, enable **Corner Vertex Mode** , and then click **Preferences** . In the Hardscape Object Settings dialog box, change the name to **Patio and Pool Flagstone**, and change other settings as shown in the next figure, and then set the Flagstone pattern settings (2.00' [.610m]), as shown in the next figure. Click **OK** twice, and then snap to the construction boundary vertices—press the T key to pick up edges as necessary for intersections—(the same way you created the driveway and front porch hardscapes in [Exercise 7](#)) to complete the paved patio/pool area hardscape, as shown at right.

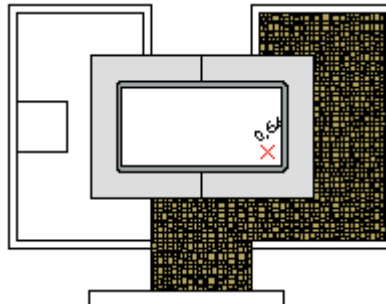

- In the Object Info palette, change the hardscape object's Class to **Surface-Paver-Flagstone**. Press the X key twice, and examine the completed hardscape, as shown at right.



Next, you create a circular paved patio hardscape in the garden.

- From the Basic tools palette, click the **Circle** tool . In the Tool bar, enable **Circle by Radius Mode** . For the center point, click approximately where shown at left, and then type 4.5' [1.372m] to set the floating data bar's L (radius) field. Press Enter twice to complete the 9' [2.743m] diameter circle, as shown at right (leave the circle selected for the next step).

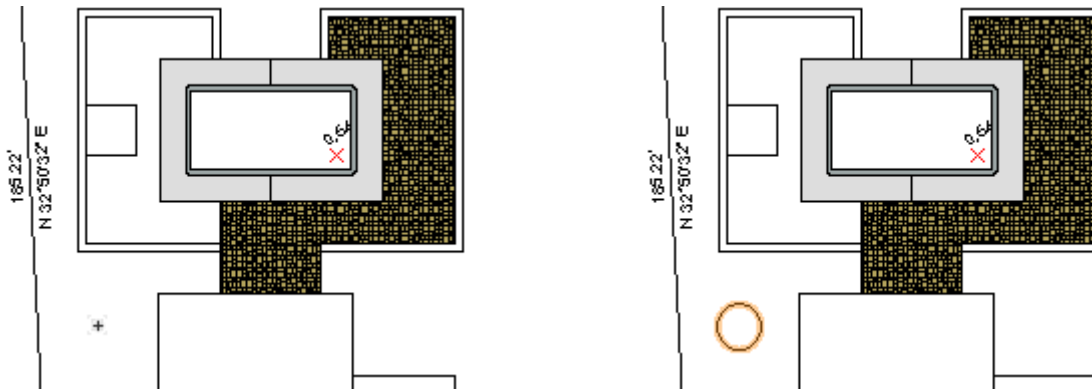

- Zoom in on the area shown at left. From the menu, select **Modify > Convert > Objects from Polyline**. In the Create Objects from Polyline dialog box, adjust settings (shown in the next figure) and then click **OK** to create the hardscape object. In the Object Info palette, change the Class and Hardscape Name settings, as shown in the next figure. Press the X key twice and examine the completed garden patio hardscape, as shown at right.

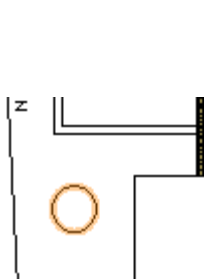

Create Objects from Polyline

Object Type:

Offset:

Custom Offset:

Show Properties Dialog

Delete Source Poly

Continuous Spacing

Object Info - Shape

Shape | Data | Render

Hardscape

Class:

Layer:

X:

Y:

Z:

Screen X:

Screen Y:

Screen Z:

Rotation:

Hardscape Settings...

Save Hardscape...

Hardscape Name:

Sketch style:

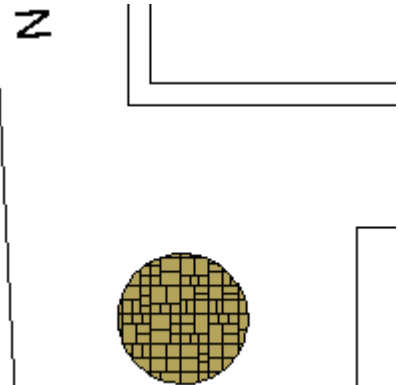

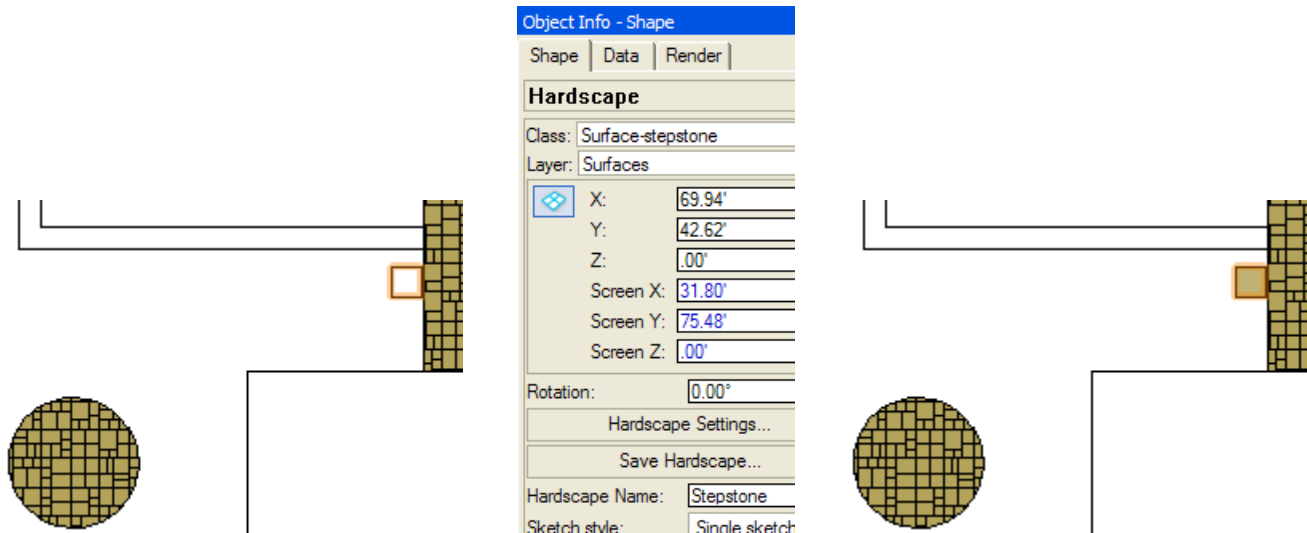

Next, you create a stepstone hardscape that you duplicate later in this exercise to create a path and rectangular array.

- From the Basic tools palette, click the **Rectangle** tool . Draw a 2' by 2' [.610m by .610m] rectangle approximately where shown at left. Repeat the polyline conversion process to create a hardscape object. In the Object Info palette, change the Class and Hardscape Name settings, as shown at center, and then click **Hardscape Settings**. In the Hardscape Object Settings dialog box, change the Joint Pattern to **None**. Press the X key twice, and then examine the completed stepstone hardscape object, as shown at right.



Drawing pathway hardscapes

Next, you draw a pathway hardscape to connect the pool house and pool deck.

- Adjust the view to display the pool house rectangle and pool. From the Site Planning tool set, click the **Hardscape** tool . In the Tool bar, click **Preferences** . In the Hardscape Object Settings dialog box, adjust settings (4.00' [1.219m]) as shown at left, and then click **OK** to save the changes. Snap to the left midpoint of the pool deck (shown at center), and then hold down the Shift key for the perpendicular constraint, and click once between the pool house rectangle, and then double-click the pool house rectangle's midpoint to create the hardscape. In the Object Info palette, change the Class to **Surface-concrete**, and then press the X key twice, and examine the completed walkway hardscape, as shown at right.

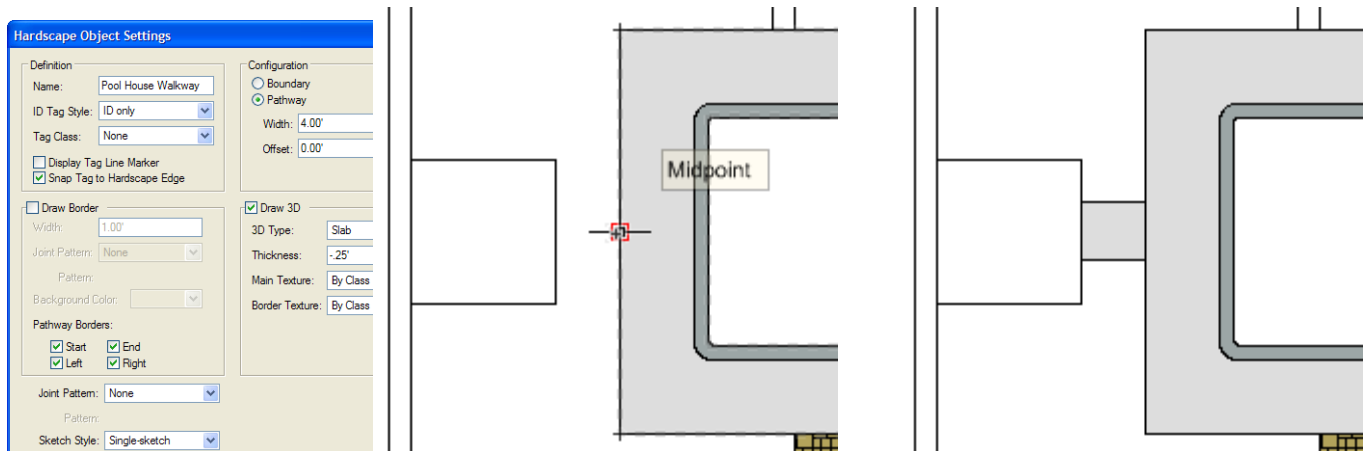

Note: Even though the path for this hardscape is a straight line, you must add another vertex because you cannot create a pathway hardscape object from only two points.

Next, you draw an L shaped pathway hardscape to connect the garage with the rear door patio.

- Adjust the view to display the garage and pool. In the Navigation palette, turn on visibility of the **Building** class.

Click the **Hardscape** tool , and then snap to the rear garage door's midpoint, as shown at left. Move your cursor straight up, and then snap when the Object/Vertical SmartCursor cue is displayed on the construction geometry (seat wall edge), as shown at center. Double-click the endpoint where the seat wall meets the flagstone hardscape to create the walkway, as shown at right.

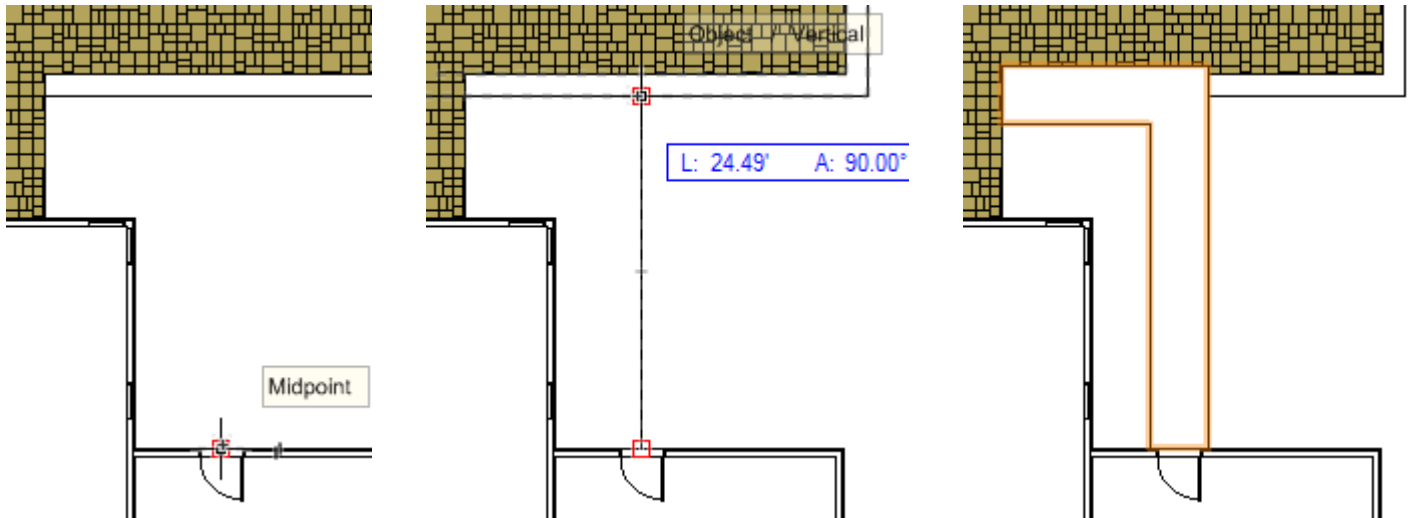

Next, you reshape the hardscape's path to compensate for the zero offset distance.

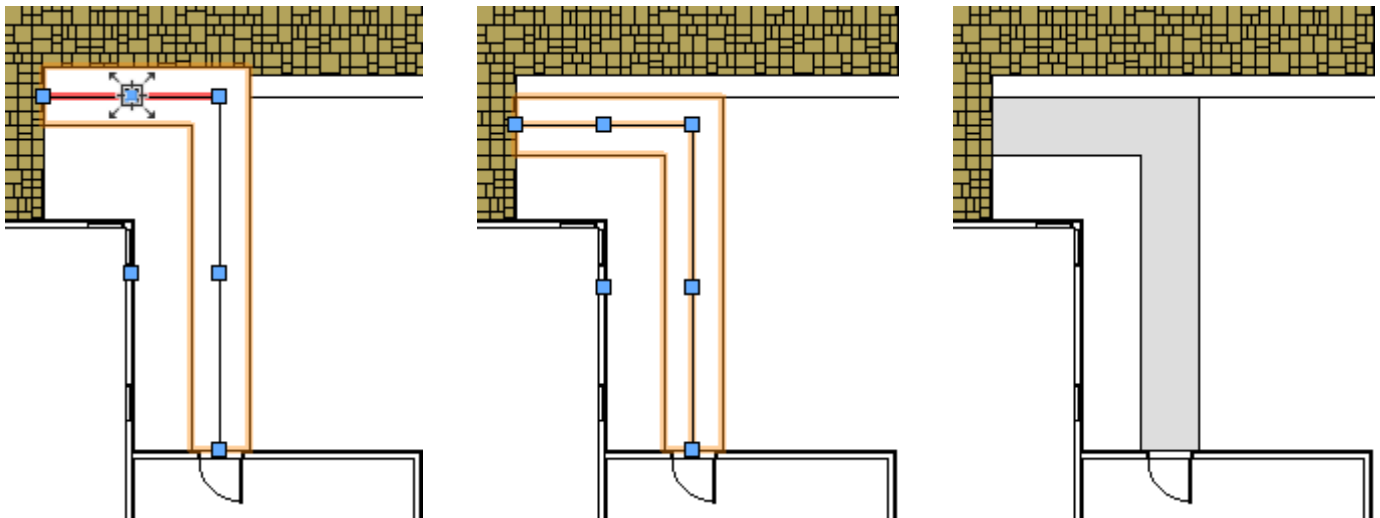

- Press the X key, and then double-click the pathway hardscape. Click the path's top middle grip (shown at left) to "pick it up", and then start moving the cursor downward. Enter 2' [.610m] to activate the floating data bar's L field and set the value, then press Tab and enter -90 for the Angle. Press Enter twice to complete the reshape operation, as shown at center. In the Object Info palette, change the Class to **Surface-concrete**, and change the Hardscape Name to **Garage and Patio Walkway**. Press the X key twice, and then examine the completed walkway hardscape, as shown at right.



Note: If the short side of your "L" walkway isn't perfectly horizontal: Delete the walkway, then turn off visibility of the **Surface-Paver-Flagstone** class (in the Navigation palette) to hide the flagstone hatching, and repeat the steps 9 and 10.

Duplicating a hardscape object along a path

Next, you create a stepstone hardscape object, and then you duplicate it along a polyline to create a footpath that connects the rear door patio with the garden patio.

11. Adjust the view to display the circular patio and stepstone. From the Basic tools palette, click the **Polyline** tool . In the Tool bar, enable **Corner Vertex Mode** , and click the center of the stepstone and then click once to draw a horizontal line segment, as shown at left. Enable **Tangent Arc Mode** , and then double-click near the circular hardscape to complete the polyline, as shown at right. From the menu, select **Modify > Convert > Convert to Polygons** so you can use the polygon as a path object (leave the polygon selected for the next step).

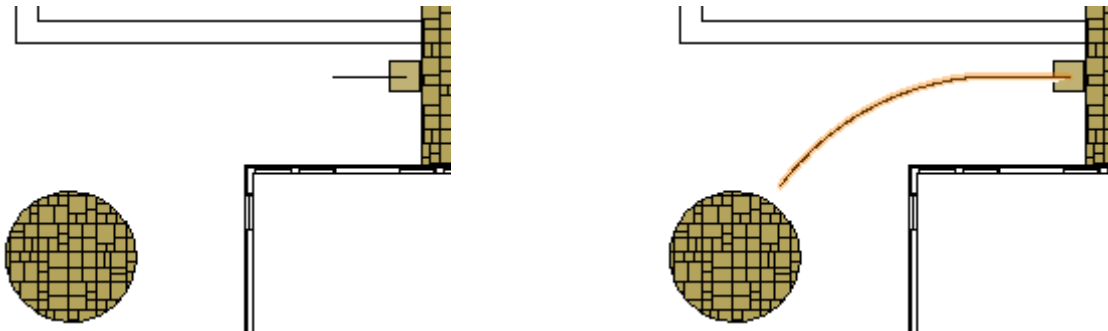

12. Press the X key, and then select the stepstone hardscape object to add it to the current selection. From the menu, select **Edit > Duplicate Along Path**. In the Duplicate Along Path dialog box, adjust settings as shown at left, and then click **OK** to create the duplicates. Press the X key, and then delete the polygon. Examine the completed stepstone footpath, as shown at right.

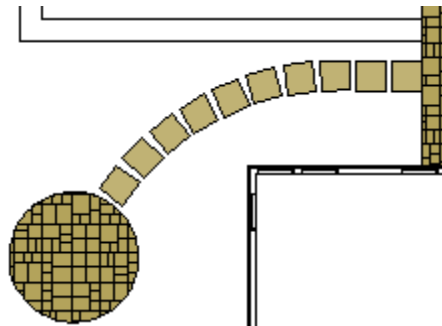
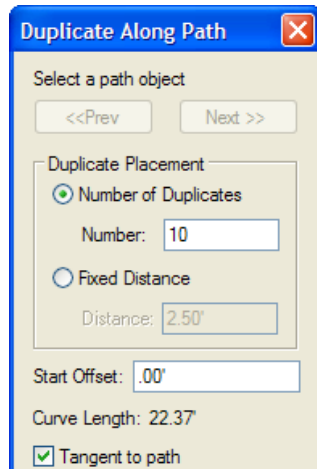

Creating a duplicate array from a hardscape object

Next, you create a rectangular array of stepstones to provide a wide footpath to the gazebo.

13. Adjust the view to display the footpath and seat walls. Hold down the Ctrl key (to activate copy mode) and drag the first stepstone hardscape object to copy it outside the pool deck, approximately where shown at left. From the menu, select **Edit > Duplicate Array**. In the Duplicate Array dialog box, adjust settings (2.50' [0.762m], 1.00' [0.305m]), as shown at right, and then click **OK** to create the stepstone array (leave the entire array selected for the next step).

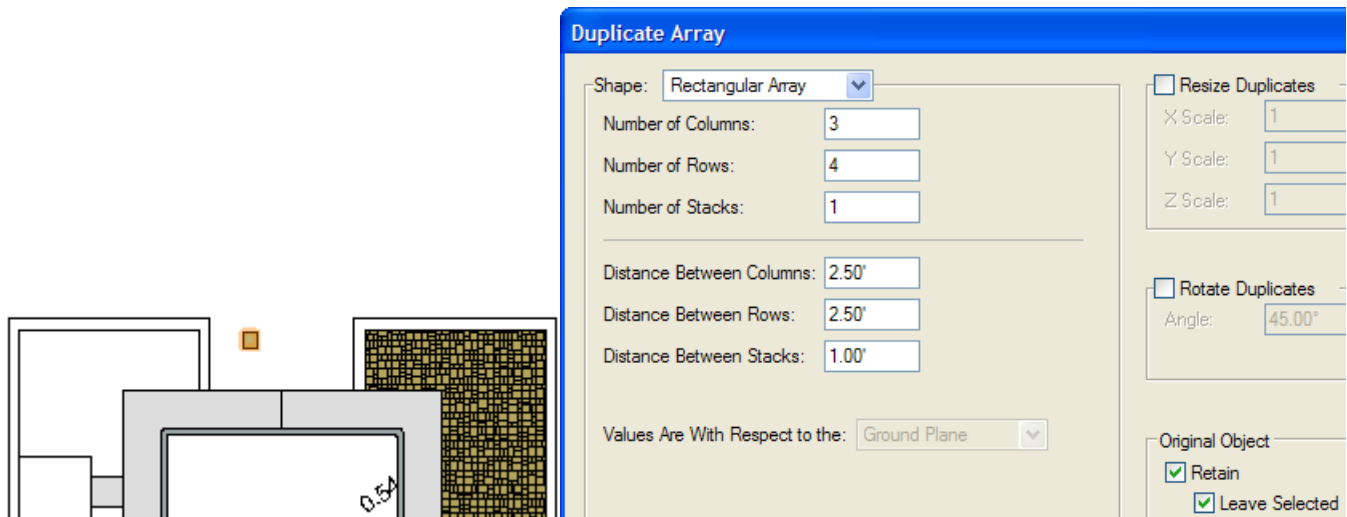

14. In the Navigation palette, select the Design Layers tab, and then turn on visibility of the **Architecture** layer. Adjust the view so you can see the array and gazebo. With all 12 hardscapes still selected, drag them into position by the midpoint on the top edge of the top center rectangle, and drop the array on the bottom center of the gazebo roof edge (you can acquire smart points and find the intersection of extension lines, or place it approximately at the midpoint), as shown at center. Hold down the Shift key, and then press the Down arrow key three times to nudge the stepstones into their final position. Clear the selection, and examine the completed stepstone array, as shown at right.

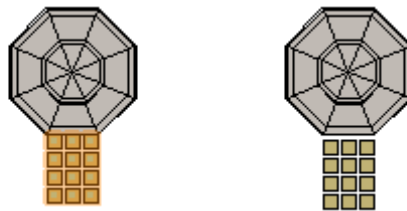

15. Save the file.

Exercise 14: Drawing Planting Areas

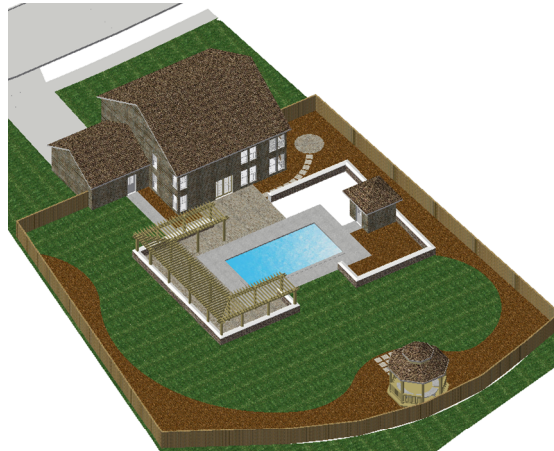

In this exercise, you draw a boundary for the curved planting bed area, and then you create polygons from inner boundaries and convert them to landscape area objects that represent the planting bed and turf areas.

The completed exercise is shown in the following figure:





Drawing the planting bed areas

You start the exercise by opening a starting file, and then you draw a polyline to represent the inside boundary of the curved planting bed.

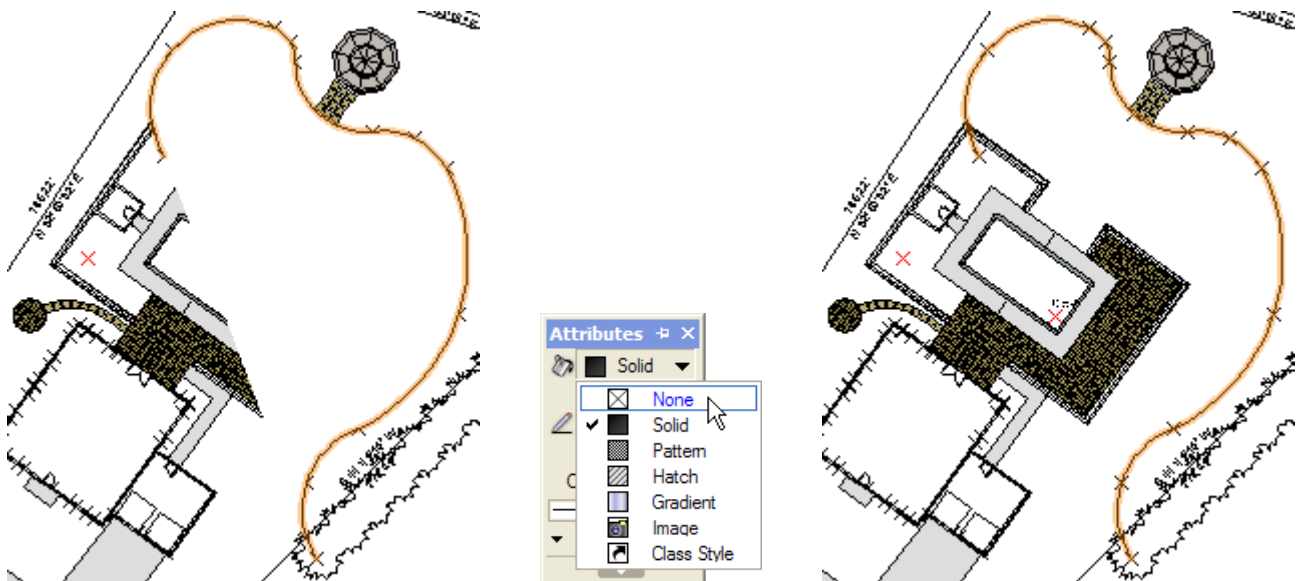
1. To ensure proper operation of the remaining exercises, close your **Landscape.vwx** file (if it's open), and then rename it. Open the **GS-VWLx14-Step01.vwx** file. Notice that 13 2D loci are already selected. From the menu, select **File > Save As**, and then save the file under the name **Landscape.vwx**.
2. From the Basic tools palette, click the **Polyline** tool . In the Tool bar, enable **Point on Arc Mode** . Carefully click the 13 locus points in order (press the Z key to temporarily zoom in if necessary), starting at the lower right—double-click the last point inside the seat wall to create the polyline—as shown at left. With the polyline selected, change the Fill Style to **None** in the Attributes palette (shown at center) to complete the polyline, as shown at right.



Next, you adjust layer and class visibilities, and then you create the curved planting bed polygon from its boundary.

3. Press the X key twice to clear the current selection, and then in the Navigation palette:
 - Select the Classes tab, and then turn off visibility of these classes: **Building**, **Existing-remain**, **Masonry**, **NonPlot**, **Wall-Exterior**, and **Water Feature**.
 - Select the Design Layers tab, turn off visibility of the **Architecture** layer, and then turn on visibility of the **Beds** layer.
4. From the Basic tools palette, click the **2D Polygon** tool , and make sure **Polygon From Inner Boundary Mode**  is active. Click anywhere between the curved polyline and the privacy fence to create the polygon, as shown (leave the polygon selected for the next step).

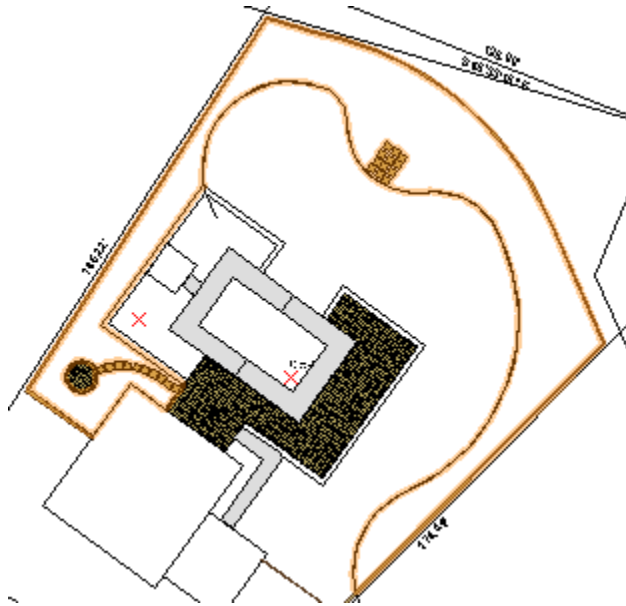

Next, you convert the polygon to a landscape area object, which you then configure as a planting bed.

5. From the menu, select **Modify > Convert > Objects from Polyline**. In the Create Objects from Polyline dialog box, adjust settings as shown at left. Click **OK** to create the planting bed. In the Attributes palette, click **Solid Fill Color**, then select the brown color (shown at center) to color the landscape area, as shown at right (leave the landscape area selected for the next step).

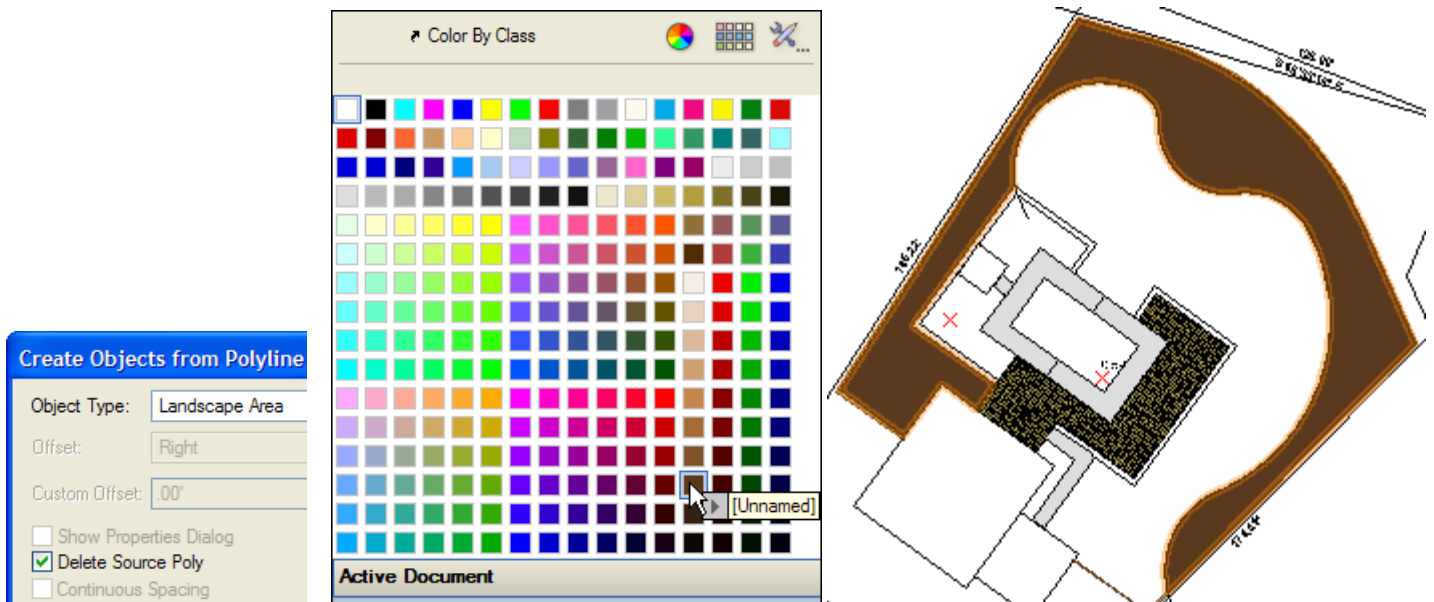

6. In the Object Info palette, change the landscape area's Name to **Main Planting Bed**, as shown at left. Select the Render tab and select **Nature LS/Mud** from the texture drop down list, as shown in the next figure at left, to complete the planting bed, as shown at right. Right-click the landscape area, and select **Send > Send to Back** from the context menu. Press the X key, select the original curved polyline (select it *outside* the property line), and then select the Shape tab in the Object Info palette, and change the Class to **NonPlot** to turn off its visibility, but save it in case you need to revise the boundary later. The complete main planting bed is shown at right.

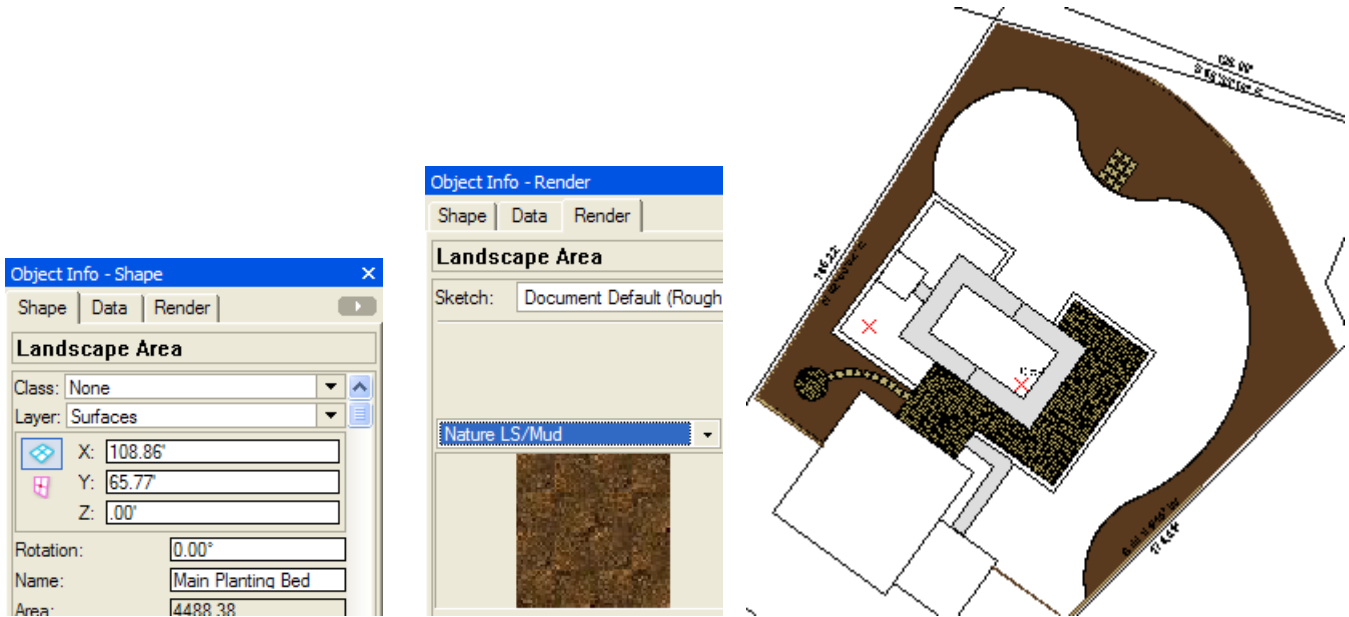

7. Repeat the polygon creation/conversion and property changing (brown fill color and **Nature LS/Mud** texture) process to create the other two planting beds. In the Object Info palette, change the name of the landscape area next to the:

- Pool deck to: **Pool House Planting Bed**
- House to: **Walkway Planting Bed**

Press the X key to clear the selection, and examine the completed planting beds, as shown.

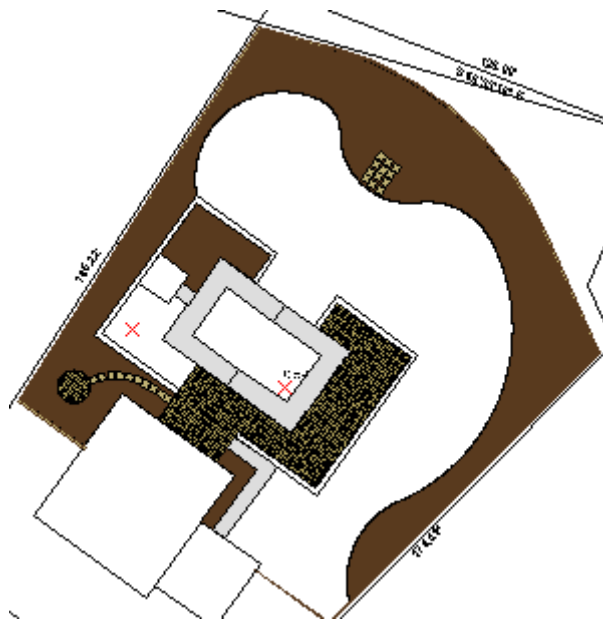

Note: You mirror the planting bed inside the seat walls in [Exercise 17](#), after you insert all plant objects).

Filling in the turf areas

Next, you temporarily hide the main planting bed, and adjust class visibilities to facilitate the polygon conversion process for creating both turf areas.

8. Select the main planting bed, and then change its Layer to **Upperstory** in the Object Info palette. In the Navigation palette:
 - Turn on visibility of the **NonPlot** class
 - Turn off visibility of the **Surface-Paver-Flagstone** class
 - Activate the **Turf** class
9. Click the **2D Polygon** tool . Click anywhere between the curved polyline and the seat walls to create the polygon, as shown at left. Repeat the landscape area conversion process, and then change Name to **Proposed Turf** in Object Info palette. Press the X key twice to clear the selection, and then examine the completed proposed turf landscape area, as shown at right.

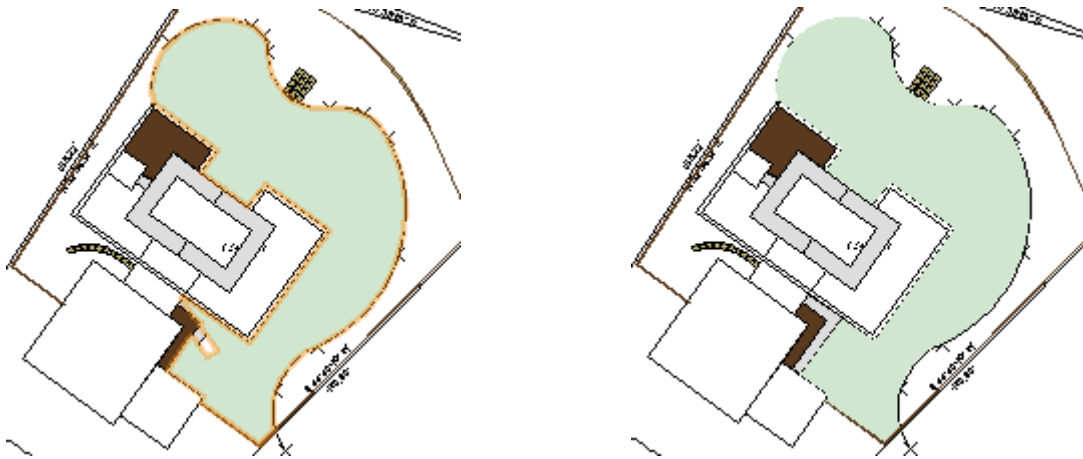

Next, you create more polygons from boundaries. You then modify them and combine them into a single polygon that you convert to the existing turf landscape area.

10. Repeat the polygon creation and conversion process to create two other polygons, as shown (highlighted for clarity) at left. Press the X key, and hold down the Shift key and select both objects. Right-click the selection and select **Add Surface** to combine them into a single polyline, as shown at right.



Next, you subtract the area of the driveway and porch from the polygon.

11. In the Navigation palette, turn on visibility of the **Existing-remain** class (you can't see the driveway and porch because the polyline on top in the stacking order). Right-click the polygon and select **Send > Send to Back**. Hold down the Shift key and then select the porch and driveway hardscape objects to add them to the selection set (3 objects should now be selected). Right-click the selection and select **Clip Surface** to complete the polygon, as shown at left. Select only the clipped polygon, and then repeat the polygon to landscape area conversion process. Change the landscape name to **Existing Turf**, to complete the other turf area, as shown at right.



12. In the Navigation palette, activate the **01-Working-Upperstory** saved view (the main planting bed is already selected). In the Object Info palette, change the main planting bed's Layer back to **Surfaces**. Activate the **Iso-Without Plants** saved view (you may need to activate it twice), and then examine the completed planting bed and turf landscape areas, as shown at right.

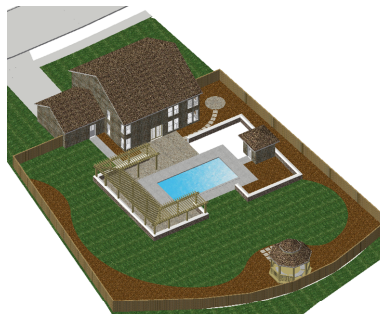

13. Save the file.

Section 5: Creating the Planting Plan

In three exercises, this section covers the following processes in the in the landscape design project:

- Placing plants by polygon vertices (pg 80)
- Placing plants by polygon edges (pg 81)
- Placing plants by arrays (pg 81)
- Using the **Objects from Polylines** command to convert polygons to plants (pg 82)
- Creating and configuring the plant database (pg 84)
- Searching the plant database (pg 85)
- Searching the web for plant data (pg 85)
- Creating a plant data sheet (pg 86)
- Placing individual trees (pg 87)
- Placing trees by polygon vertices (pg 88)
- Placing trees by polygon edges (pg 88)
- Mirroring the completed landscape area (pg 89)

In these exercises, you continue “building” the design vertically by inserting mid-level plants in the drawing. After a brief introduction to the plant database, you complete the initial planting plan by adding the top-level trees.

Exercise 15: Placing Plants

In this exercise, you use a variety of the **Place Plant** tool's placement modes—with minimal guidance—to create groundcover and mid-level plants in the landscaping design. You then complete the exercise by converting a polygon to a plant grouping.

The completed exercise is shown in the following figure:

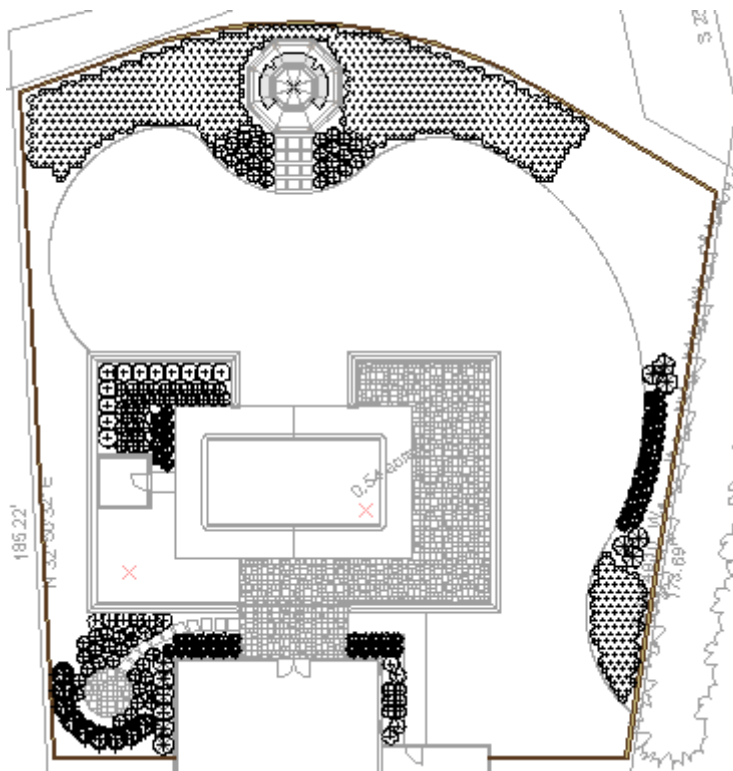

General **Place Plant** tool instructions for all sections of this exercise:

- Zoom and pan as necessary. Check the dynamic preview before you click points for plant paths or boundaries.
- When placing plants with multi-segments: press the Delete key to revert a segment; double-click the last vertex to terminate the plant (it's not necessary to close profiles for rectangular and triangular arrays). Hold down the Shift key to constrain horizontal and vertical lines when you need to follow orthogonal constructed elements.
- It may take several seconds to complete the creation of larger plant groups. Do not activate any other tools or commands until the creation process is completed.
- If necessary, you can press the X key, and drag plant groups to reposition them after they are created. Or, you can reshape plants by double-clicking them and editing the path. You can then move, delete, or add vertices to achieve the desired shape. Use the **Undo** command as necessary, or delete and redraw plants that would otherwise require too many edits to achieve the desired result. If you place the wrong plant type, click **Replace Plant** in the Object Info palette, then select the correct plant.
- When the **Place Plant** tool is active, select plants from the Plant ID drop-down list in the Tool bar. If the plant type you want to activate is already in the drawing, activate **Pickup Mode** , and then click on the plant to activate it (and its mode).
- Refer to the Online Help's Adding Plants to the Design topic for more information about plant placement modes.

General Exercise Notes:



- 1) Precise plant placement instructions are intentionally omitted so you can learn how to dynamically place and reshape plants in rectilinear and free-form configurations.
- 2) To eliminate excessive mode switching, you draw plants in order by placement modes - not the ideal layout order.
- 3) To speed up display performance in the design phase, the **Plants-Components-Bloom**, **-Canopy**, and **-Color Fill** classes are turned off in all saved views.

Placing plants by polygon vertices

You start the exercise by inserting shrubs and perennials using the **Place Plant** tool's **Poly-Vertex Placement Mode**.

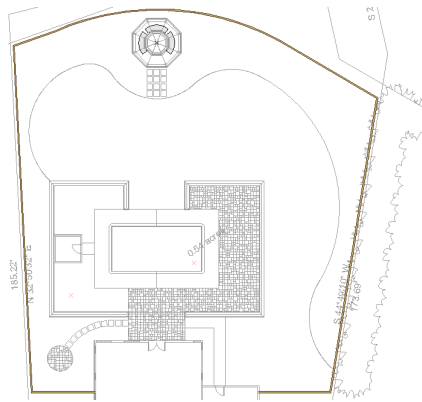
1. If you did not complete Exercise 14—or you are unsure of your file's accuracy—open the **GS-VWLx14.vwx** file.
2. In the Navigation palette:
 - Activate the **03-Working-Beds** saved view (you may need to activate it twice), then activate the **Rotated Top** saved view.
 - Select the **Classes** tab, and then turn off visibility of the **Demolition**, and **Wall-Exterior** classes.
 - Select the **Design Layers** tab, and then change the visibility of the **Architecture**, **Surfaces**, and **Base Plan** layers to **Gray** (shown at left). Object color fills disappear, and object lines are de-emphasized, as shown at right.



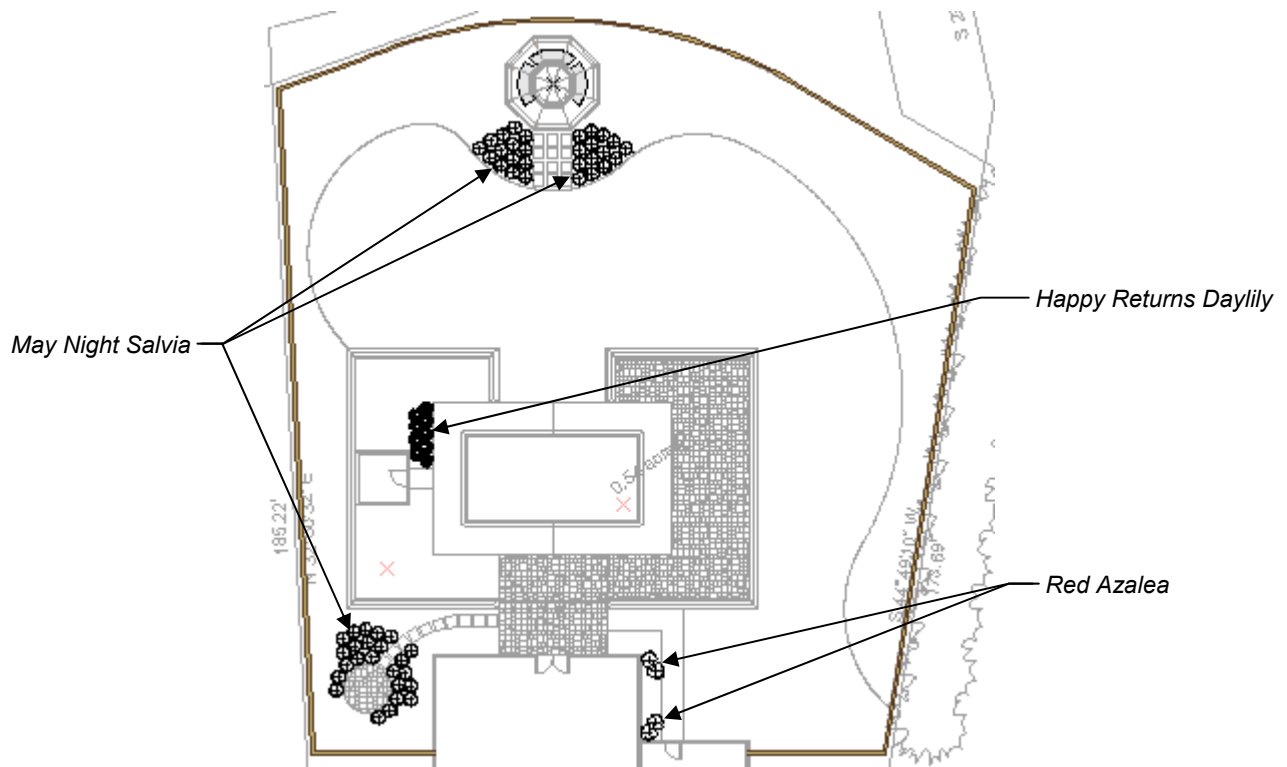

3. From the Site Planning tool set, click the **Place Plant** tool . In the Tool bar, enable **Poly-Vertex Placement Mode** , and then create the plant objects, similar to the patterns shown (see [general instructions](#) at the beginning of this exercise).



Placing plants by polygon edges

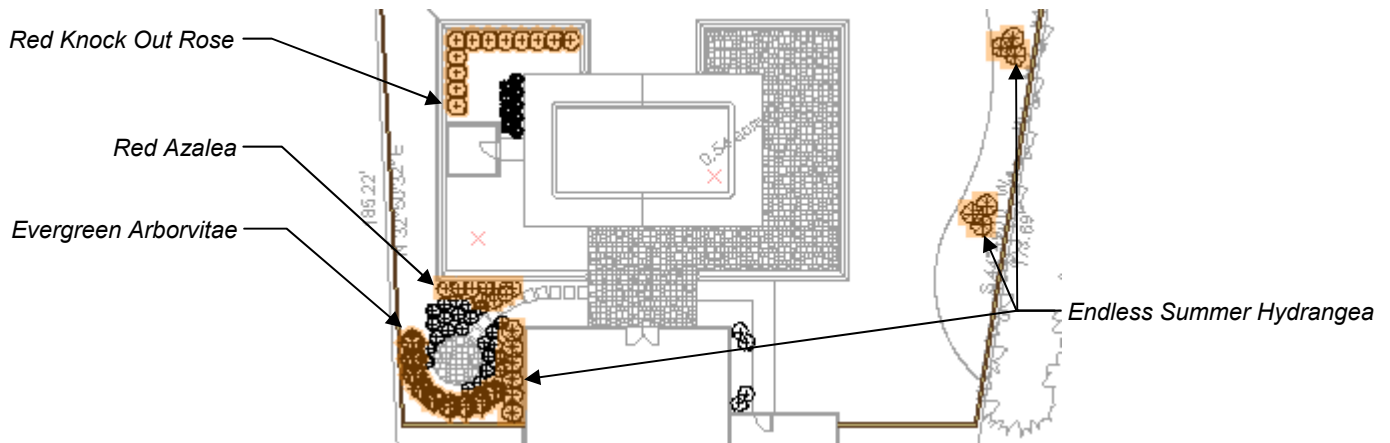

Next, you insert evergreens, shrubs, and perennials using the **Place Plant** tool's **Poly-Edge Spaced Mode**.

4. Zoom in on the area shown. Click the **Place Plant** tool , and then enable **Poly-Edge Spaced Mode** . Create the plant objects, similar to the patterns shown (highlighted for clarity; see [general instructions](#) at the beginning of this exercise).





Placing plants by arrays

Next, you insert ground cover and perennials using the **Place Plant** tool's **Triangular Array Mode**.

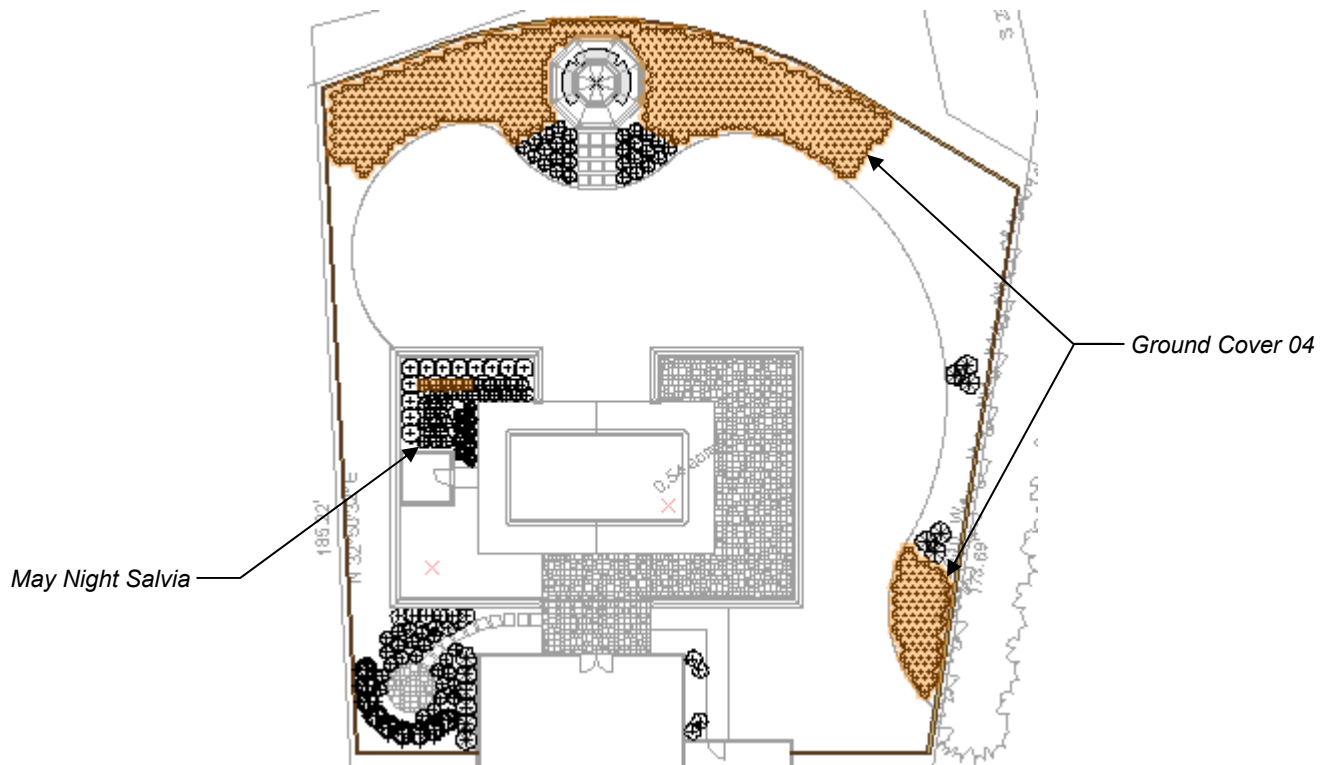
5. Zoom out, then click the **Place Plant** tool , and enable **Triangular Array Mode** . Create the plant objects, similar to the patterns shown (highlighted for clarity; see [general instructions](#) at the beginning of this exercise).





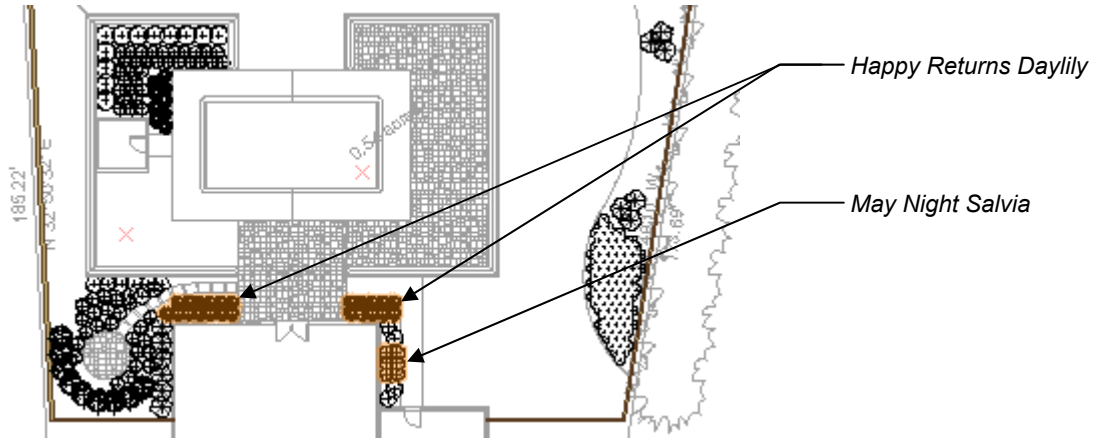

Next, you insert perennials using the **Place Plant** tool's **Rectangular Array Mode**.

6. Zoom in on the area shown. Click the **Place Plant** tool , and then enable **Rectangular Array Mode** . Create the plant objects, similar to the patterns shown (highlighted for clarity; see [general instructions](#) at the beginning of this exercise).





Using the Objects from Polylines command to convert polygons to plants

Next, you create two rows of plants that conform to a curved boundary. You first draw a double-line polygon along the boundary to mark the centerline of the first row, then you draw another polygon and convert it to a single plant object with two rows of plants.

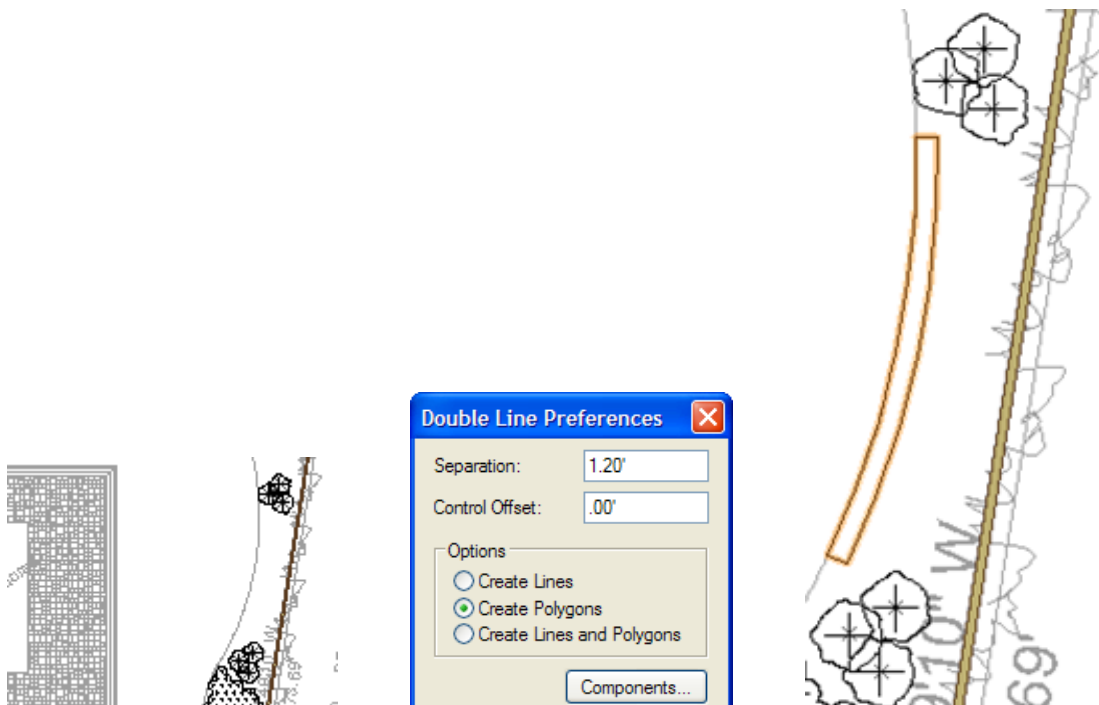
7. Press the X key twice to clear the current selection. Click the **Place Plant** tool , and enable **Poly-Edge Spaced Mode** , then activate the **Happy Returns Daylily** Plant ID. Zoom in on the area shown at left. From the Basic tools palette, click the **Double-Line Polygon** tool . Enable **Top Control Line Mode** , then click **Double-Line Polygon Preferences** . Adjust settings (1.20' [0.366m]) in the Double Line Preferences dialog box, as shown in the next figure, and then click **OK**. Starting at the bottom, snap to the curved planting bed boundary on approximately 4' [1.219m] intervals, then double-click the last point to complete the polygon, as shown in the next figure (highlighted as 2D locus points for clarity), to complete the polygon, as shown at right.



8. With the **Double-Line Polygon** tool  still active, click **Double-Line Polygon Preferences** . Adjust settings as shown at left (1.70' [.518m]), and then click **OK**. Draw another polygon by snapping to the vertices from bottom to top on the right side of the first polygon (approximately 4' [1.219m] intervals), as shown at right.

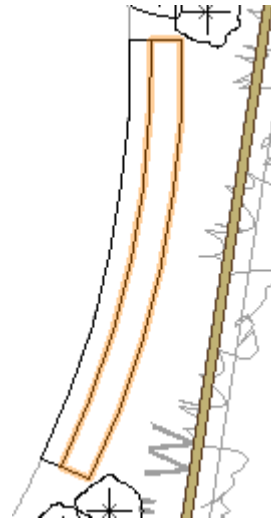
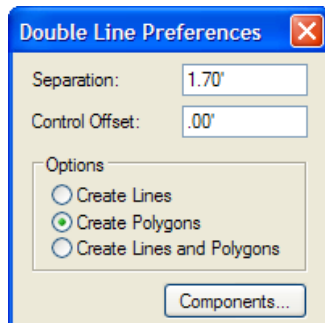

9. Press the X key, then select the first polygon, and then delete it. Select the new polygon, and then select **Modify > Convert > Objects from Polyline** from the menu. In the Create Objects from Polyline dialog box, adjust settings as shown at left. Click **OK** to create the plant object along the planting bed boundary (it may take several seconds), as shown in the next figure. If necessary, move the Endless Summer Hydrangea plant object(s) to eliminate interference, and then clear the selection, to see the completed plant, similar to the one shown at right.

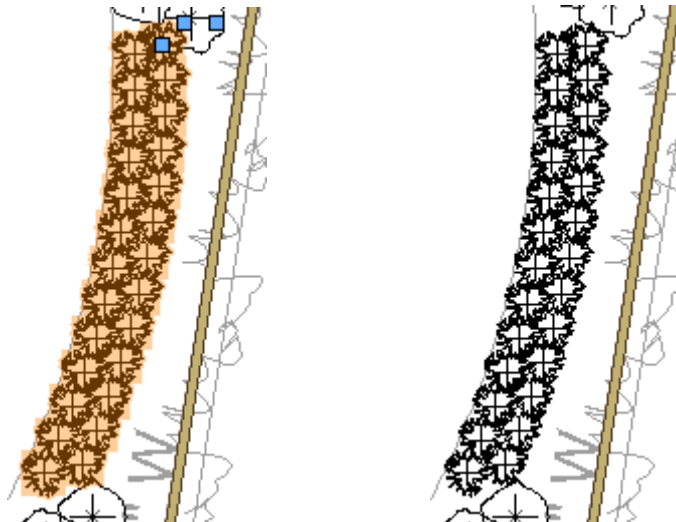
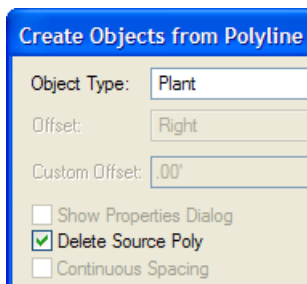

10. Save the file.

Exercise 16: Introduction to the Plant Database

In this exercise, you create the standalone plant database, and then you search for one of the plants. You then search for plant images on the web. You complete the exercise by creating a plant data sheet for the client.

The completed exercise is shown in the following figure:

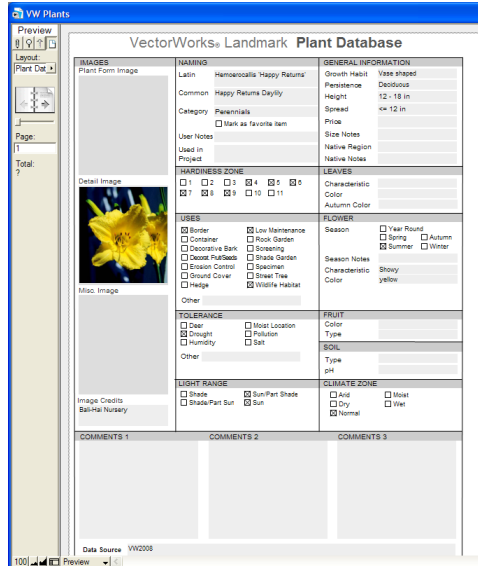

Creating and configuring the plant database

You start the exercise by creating and configuring the plant database.

1. From the menu, select **Landmark > VW Plants Database**. In the Choose Plant Database Location dialog box, click **OK** to accept the default **User Folder** option for the location. In the VW Plants dialog box, enter your own user name, and then click **OK**. After several seconds, the VW Plants database is created and opened, as shown.

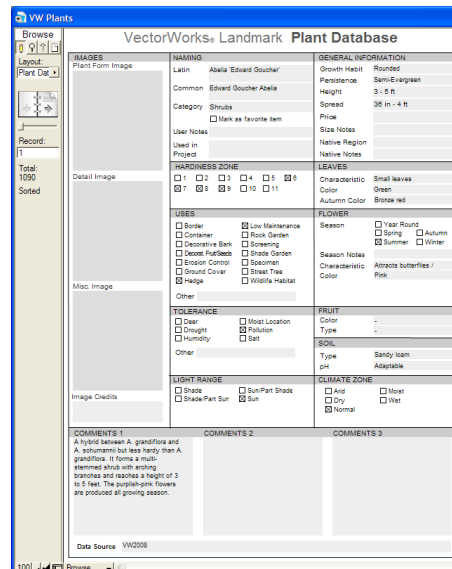

Searching the plant database

Next, you search the database for the Happy Returns Daylily plant.

- In Status Area (on the left side), click **Find**  to activate Find mode. In the Naming section, enter Happy Returns Daylily in the Common field (shown at left), and then click **Find** in the Status Area. The Happy Returns Daylily record is displayed (in Browse mode), as shown.

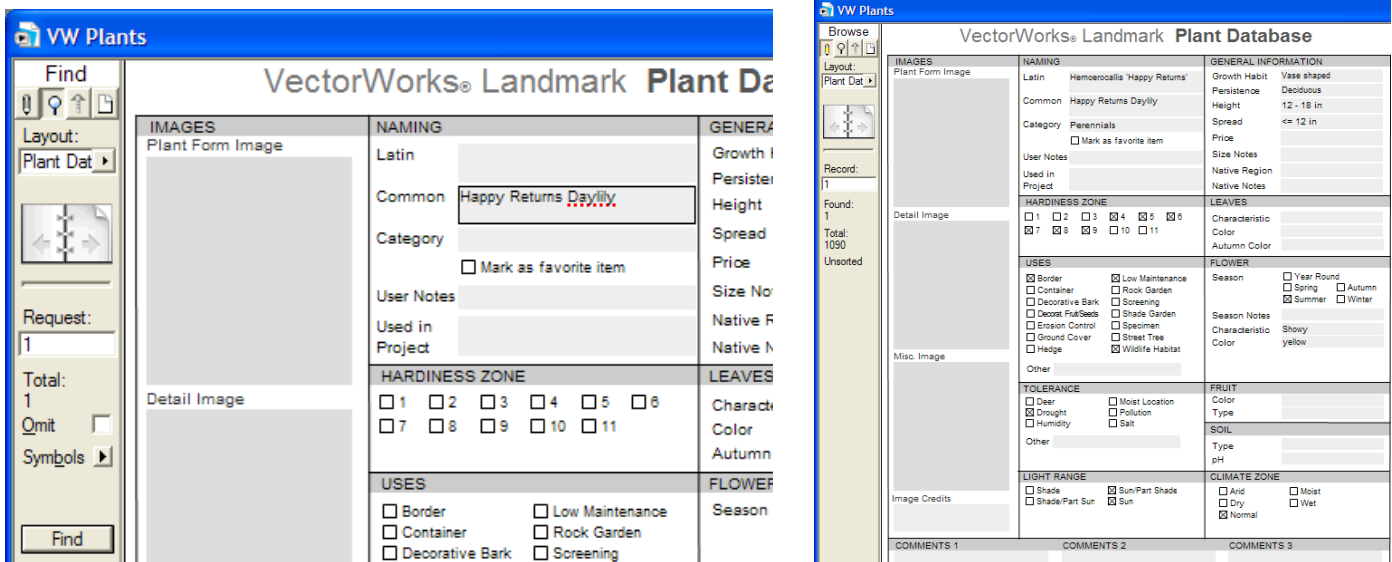

Tips:

- You can also use operators from the Symbols menu (in the Status Area) in combination with truncated names or specific letters to find records.
- In Find mode, click in a field and then Press **Ctrl+I** to open the View Index dialog box (which displays the complete list of the active field's values for all records). You can then scroll down the list (or start typing a name to jump directly to it) and double-click a value to paste it in the active field.

Searching the web for plant data

Next, you use the plant database's web search feature to find images of the Happy Returns Daylily plant.

Note: You must have Internet access for the next two steps.

- Select **Web Data** from the Layout drop-down list in the Status Area. The web layout is displayed with the Google Images tab active, displaying the results of an automatic search. If there are no search results, click the suggested "Did you mean:" search phrase, and then open any one of the image links displayed.

Note: For some plants, you may have to adjust web search criteria to achieve the desired result.

Creating a plant data sheet

Next, you paste images from the web into the plant record's image container field(s), and then you complete the exercise by previewing the printed data sheet.

- In the web browser window, click **See full-size image**, and then Right-click the image and select **Copy** from your browser's context menu. Right-click the appropriate image field in the IMAGES section (next to the Status Area), and select **Paste Bitmap** to insert the image, similar to the following example shown at left. In Status Area, select **Plant Data** from the Layout drop-down list, and then click **Preview**  to activate Preview mode, and examine how the data sheet will print. Your preview should look similar to the following example shown at right.

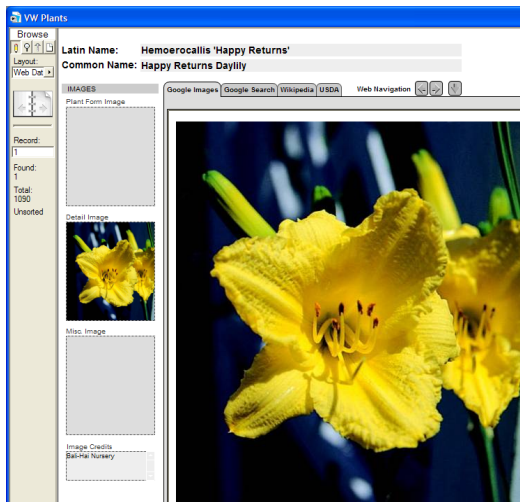

Note: It's not necessary for this exercise, but you can optionally print your data sheet by pressing **Ctrl+P**, selecting **File > Print** from the VW Plants application menu, or clicking **Print**  from the Standard tool bar.

- From the VW Plants application menu, select **File > Exit** to close the database (your changes are automatically saved).

Notes:

- The standalone plant database does not modify your **Landscape.vwx** drawing, so there are no changes to save.
- This exercise covers only one of the plant database's many functions. For more capability information, refer to the Online Help.

Exercise 17: Placing Trees

In this exercise, you complete the initial planting plan by placing trees—with minimal guidance—to create top-level trees in the landscape design.

The completed exercise is shown in the following figure:

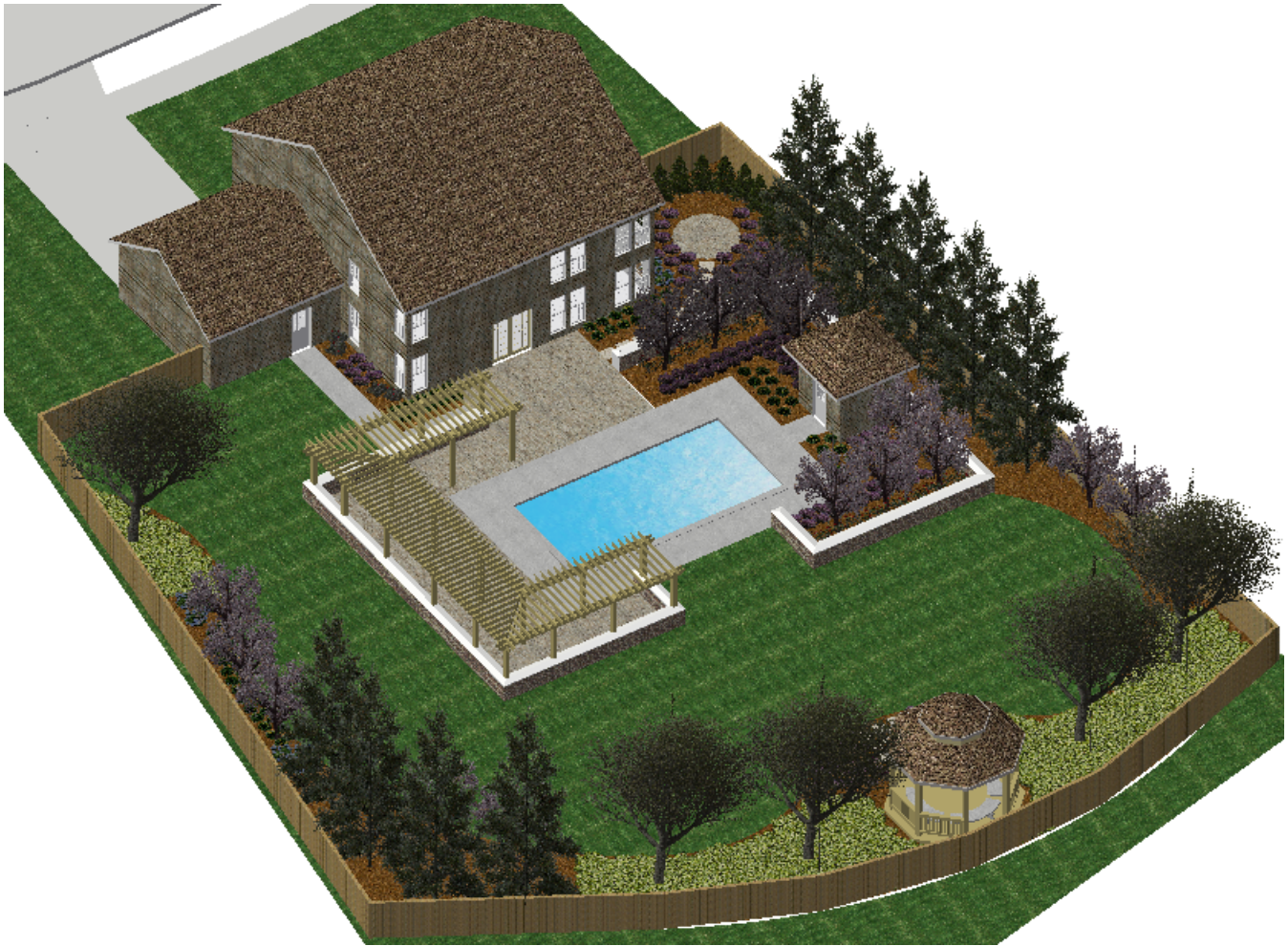



Placing individual trees

You start the exercise by inserting a flowering pear tree using the **Place Plant** tool's **Single Plant Placement Mode**.

1. If you did not complete Exercise 15—or you are unsure of your file's accuracy—open the **GS-VWLx15.vwx** file.

*Note: There were no changes to your **Landscape.vwx** file in [Exercise 16](#).*



2. In the Navigation palette:
 - Turn off visibility of the **Roof-Main** class.
 - Turn on visibility of the **Upperstory** layer, and then make it the active layer.
 - Change the visibility of the **Beds** layer to **Gray**.

- From the Site Planning tool set, click the **Place Plant** tool . In the Tool bar, enable **Single Plant Placement Mode**  and activate the **Flowering Pear** plant, then click once to insert a tree approximately where shown (highlighted for clarity; see [general instructions](#) at the beginning of Exercise 15).



Placing trees by polygon vertices



Next, you insert white crabapple trees using the **Place Plant** tool's **Poly-Vertex Placement Mode**.

- Zoom in on the area shown. From the Site Planning tool set, click the **Place Plant** tool , and then enable **Poly-Vertex Placement Mode** . Create the **White Crabapple** trees, similar to the pattern shown (highlighted for clarity; see [general instructions](#) at the beginning of Exercise 15).



Placing trees by polygon edges

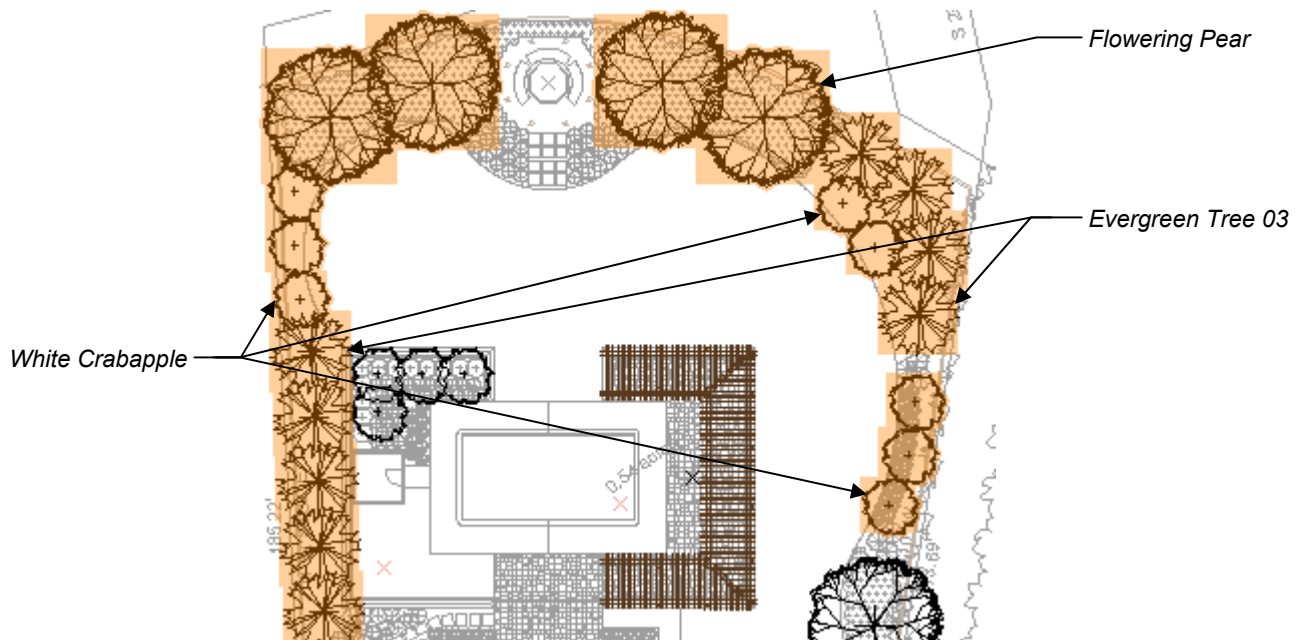

Next, you insert evergreens, shrubs, and perennials using the **Place Plant** tool's **Poly-Edge Spaced Mode**.

- Zoom in on the area shown. Click the **Place Plant** tool , and then enable **Poly-Edge Spaced Mode** . Create the trees, similar to the patterns shown (highlighted for clarity; see [general instructions](#) at the beginning of Exercise 15).



Mirroring the completed landscape area

Now that all plants and trees are inserted in the pool's symmetric landscape area, you use the **Mirror** tool to landscape area on the opposite side of the pool house.

6. Zoom in on the left seat wall area. Press Ctrl+Alt+L to toggle off **Stack Layers** viewing mode. In the Navigation palette:
 - Turn on visibility of the **Beds** and **Surfaces** layers.
 - Select **Show/Snap/Modify Others** from the Layer Options drop down list.
 - Select the Classes tab, and then turn off visibility of the **Building** class.
7. Press the X key twice, then hold down the Shift key and select the pool house planting bed, and all four plant objects, as shown at left. From the Basic tools palette, click the **Mirror** tool , and enable **Duplicate and Mirror Mode**  (if it's not already active). Snap to left and right midpoints of the pool house walkway to specify the mirror line and duplicate the objects. Press the X key twice to clear the selection, and examine the mirrored copies, shown at right.

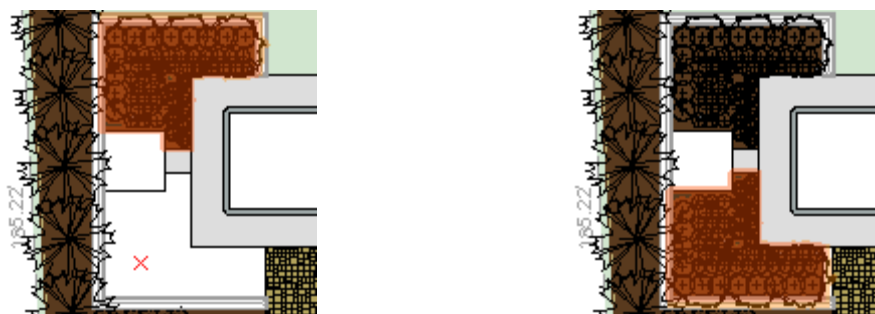

8. Press the X key twice, then double-click the mirrored planting bed. In the Edit Landscape Area dialog box, select **Path**, then click **OK**. Click the far right side's middle grip, and then hold down the Shift key and click the hardscape object, as shown at left. Clear the selection, then activate the **Iso-Full** saved view (twice if necessary), and examine the landscaping design, as shown at right.

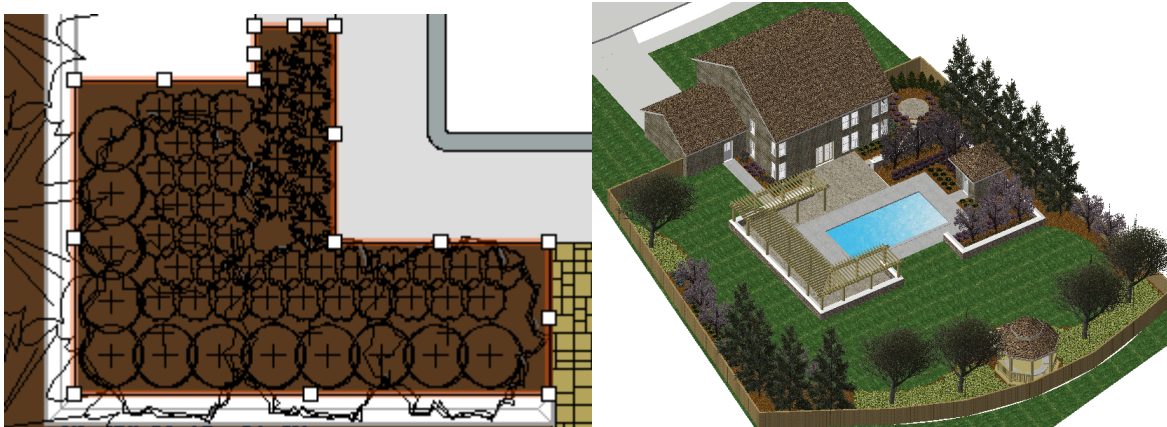

9. Save the file.

Section 6: Evaluating the Design

In one exercise, this section covers the following processes in the landscape design project:

- Opening and updating the Plant List worksheet (pg 91)
- Modifying drawing objects from the worksheet (pg 92)
- Selecting drawing objects from the worksheet (pg 93)

In this exercise, you update a pre-configured worksheet, which extracts and analyzes database record data from the drawing objects.

Exercise 18: Evaluating the Current Design

In this exercise, you open a pre-configured worksheet, and then you update plant prices with current cost data.

The completed exercise is shown in the following figure:

Plant List				
Common Name	Botanical Name	Qty	Price Ea	Extended Total
Evergreen Trees				
Colorado Spruce	Picea pungens	5	\$95.00	\$475.00
Colorado Spruce	Picea pungens	4	\$95.00	\$380.00
Emerald Green Arborvitae	Thuja occidentalis Emerald	9	\$175.00	\$1575.00
Trees				
Bradford Pear	Pyrus calleryana	2	\$60.00	\$120.00
Bradford Pear	Pyrus calleryana	2	\$60.00	\$120.00
Bradford Pear	Pyrus calleryana	1	\$60.00	\$60.00
Flowering Crabapple	Malus	3	\$30.00	\$90.00
Flowering Crabapple	Malus	4	\$30.00	\$120.00
Flowering Crabapple	Malus	2	\$30.00	\$60.00
Flowering Crabapple	Malus	4	\$30.00	\$120.00
Flowering Crabapple	Malus	3	\$30.00	\$90.00
Shrubs				
Endless Summer Hydrangea				
Endless Summer Hydrangea	Hydrangea macrophylla Endless	6	\$22.00	\$132.00
Endless Summer Hydrangea	Hydrangea macrophylla Endless	3	\$22.00	\$66.00
Endless Summer Hydrangea	Hydrangea macrophylla Endless	3	\$22.00	\$66.00
Nova Zembla Rhododendron	Rhododendron Nova Zembla	9	\$22.00	\$198.00
Nova Zembla Rhododendron	Rhododendron Nova Zembla	2	\$22.00	\$44.00
Nova Zembla Rhododendron	Rhododendron Nova Zembla	2	\$22.00	\$44.00
Red Knock Out Rose	Rosa x Knock Out (Red)	12	\$16.00	\$192.00
Red Knock Out Rose	Rosa x Knock Out (Red)	12	\$16.00	\$192.00
Wintercreeper	Euroymnus fortunei	667	\$3.25	\$2157.25
Perennials				
Happy Returns Daylily	Hemerocallis Happy Returns	9	\$18.00	\$162.00
Happy Returns Daylily	Hemerocallis Happy Returns	10	\$18.00	\$180.00
Happy Returns Daylily	Hemerocallis Happy Returns	13	\$18.00	\$234.00
Happy Returns Daylily	Hemerocallis Happy Returns	9	\$18.00	\$162.00
Happy Returns Daylily	Hemerocallis Happy Returns	27	\$18.00	\$486.00
May Night Sage	Salvia nemorosa Manchester	33	\$18.00	\$594.00
May Night Sage	Salvia nemorosa Manchester	6	\$18.00	\$108.00
May Night Sage	Salvia nemorosa Manchester	14	\$18.00	\$252.00
May Night Sage	Salvia nemorosa Manchester	14	\$18.00	\$252.00
May Night Sage	Salvia nemorosa Manchester	10	\$18.00	\$180.00
May Night Sage	Salvia nemorosa Manchester	33	\$18.00	\$594.00
May Night Sage	Salvia nemorosa Manchester	14	\$18.00	\$252.00
Ornamental Grasses				
Vines				
Aquatic Plants				
Total		1041		\$8577.75

Opening and updating the Plant List worksheet

You start the exercise by opening the plant list worksheet.

1. If you did not complete Exercise 17—or you are unsure of your file’s accuracy—open the **GS-VWLx17.vwx** file.
2. In the Resource Browser, scroll down and open the Worksheets section. Right click the **Plant List-Working Drawings** worksheet and select **Open** from the context menu. The worksheet opens, but no plant records are displayed. From the worksheet’s drop-down menu, select **Recalculate** (shown at left), to update the worksheet with current data. Resize the worksheet by dragging the opposite corners so you can see as many rows and columns as your screen resolution permits, as shown at right.

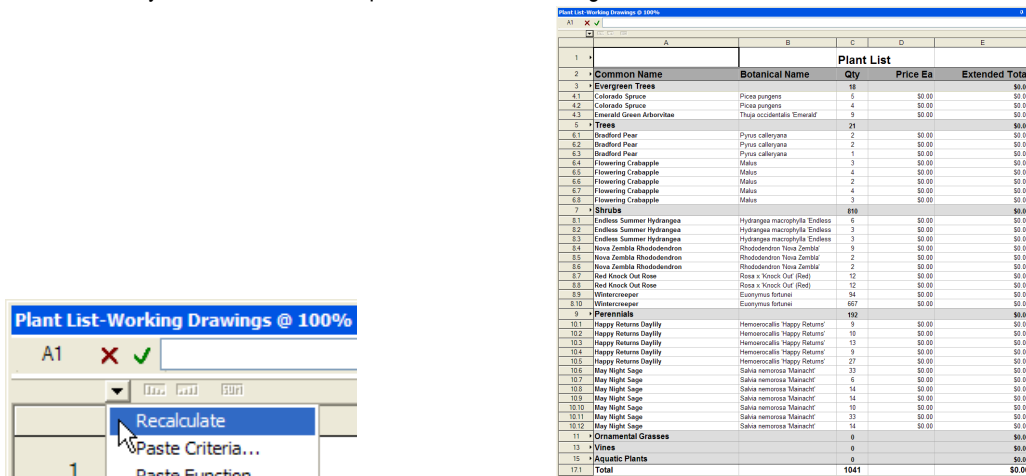

Notes:

- 1) Do not be concerned if any of your quantities differ from the above figure, as some variation is expected between the figures from the master file, and the plant boundaries and paths you created in the previous exercise.
- 2) The worksheet records are intentionally not summarized for the earlier design phases so you can select individual plants from the worksheet. You summarize them later in [Exercise 20](#), after you see the effect of changing plant groupings.
- 3) The price field is intentionally left blank for all plant definitions because it’s easier to change them in the worksheet with up to date prices that reflect current market conditions and quantities required per project.

Modifying drawing objects from the worksheet

Next, you add current plant prices (for all instances *and* the plant definition), directly from the worksheet.

3. Change the price values for all plants, as shown (see Notes below figure). To do this, click in the appropriate Price Ea cell, then enter the value and press Enter to update the worksheet and drawing objects.

Plant List-Working Drawings @ 100%					
✕ ✓ \$18.00					
	A	B	C	D	E
1	Plant List				
2	Common Name	Botanical Name	Qty	Price Ea	Extended Total
3	Evergreen Trees		18		\$886.50
4.1	Colorado Spruce	Picea pungens	5	\$85.00	\$425.00
4.2	Colorado Spruce	Picea pungens	4	\$85.00	\$340.00
4.3	Emerald Green Arborvitae	Thuja occidentalis 'Emerald'	9	\$13.50	\$121.50
5	Trees		21		\$780.00
6.1	Bradford Pear	Pyrus calleryana	2	\$60.00	\$120.00
6.2	Bradford Pear	Pyrus calleryana	2	\$60.00	\$120.00
6.3	Bradford Pear	Pyrus calleryana	1	\$60.00	\$60.00
6.4	Flowering Crabapple	Malus	3	\$30.00	\$90.00
6.5	Flowering Crabapple	Malus	4	\$30.00	\$120.00
6.6	Flowering Crabapple	Malus	2	\$30.00	\$60.00
6.7	Flowering Crabapple	Malus	4	\$30.00	\$120.00
6.8	Flowering Crabapple	Malus	3	\$30.00	\$90.00
7	Shrubs		810		\$3455.25
8.1	Endless Summer Hydrangea	Hydrangea macrophylla 'Endless	6	\$22.00	\$132.00
8.2	Endless Summer Hydrangea	Hydrangea macrophylla 'Endless	3	\$22.00	\$66.00
8.3	Endless Summer Hydrangea	Hydrangea macrophylla 'Endless	3	\$22.00	\$66.00
8.4	Nova Zembla Rhododendron	Rhododendron 'Nova Zembla'	9	\$22.00	\$198.00
8.5	Nova Zembla Rhododendron	Rhododendron 'Nova Zembla'	2	\$22.00	\$44.00
8.6	Nova Zembla Rhododendron	Rhododendron 'Nova Zembla'	2	\$22.00	\$44.00
8.7	Red Knock Out Rose	Rosa x 'Knock Out' (Red)	12	\$18.00	\$216.00
8.8	Red Knock Out Rose	Rosa x 'Knock Out' (Red)	12	\$18.00	\$216.00
8.9	Wintercreeper	Euonymus fortunei	94	\$3.25	\$305.50
8.10	Wintercreeper	Euonymus fortunei	667	\$3.25	\$2167.75
9	Perennials		192		\$3456.00
10.1	Happy Returns Daylily	Hemoerocallis 'Happy Returns'	9	\$18.00	\$162.00
10.2	Happy Returns Daylily	Hemoerocallis 'Happy Returns'	10	\$18.00	\$180.00
10.3	Happy Returns Daylily	Hemoerocallis 'Happy Returns'	13	\$18.00	\$234.00
10.4	Happy Returns Daylily	Hemoerocallis 'Happy Returns'	9	\$18.00	\$162.00
10.5	Happy Returns Daylily	Hemoerocallis 'Happy Returns'	27	\$18.00	\$486.00
10.6	May Night Sage	Salvia nemorosa 'Mainacht'	33	\$18.00	\$594.00
10.7	May Night Sage	Salvia nemorosa 'Mainacht'	6	\$18.00	\$108.00
10.8	May Night Sage	Salvia nemorosa 'Mainacht'	14	\$18.00	\$252.00
10.9	May Night Sage	Salvia nemorosa 'Mainacht'	14	\$18.00	\$252.00
10.10	May Night Sage	Salvia nemorosa 'Mainacht'	10	\$18.00	\$180.00
10.11	May Night Sage	Salvia nemorosa 'Mainacht'	33	\$18.00	\$594.00
10.12	May Night Sage	Salvia nemorosa 'Mainacht'	14	\$18.00	\$252.00
11	Ornamental Grasses		0		\$0.00
13	Vines		0		\$0.00
15	Aquatic Plants		0		\$0.00
17.1	Total		1041		\$8577.75

Notes:

- 1) You only need to change the value of one line item to change all line items with the same name.
- 2) Some plants may take several seconds to update.

Selecting drawing objects from the worksheet

Next, you select a plant in the drawing directly from the worksheet, and then you verify the price change.

4. Right-click Item 10.1 (in the row heading column, as shown at left), and then select **Select Item** from the context menu. In the View bar, notice that the layer is activated. Close the worksheet, and notice that the view is adjusted to display the selected plant, as shown at right. In the Object Info palette, select the Data tab. Scroll down the Record Fields list, and notice that the Price:18 and Extended Price: 162 values reflect the change you made in the worksheet, as shown.

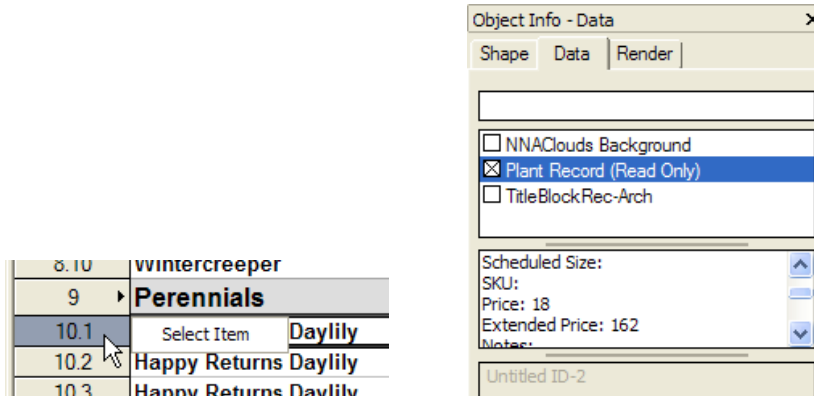

Note: Your Extended Price value may vary.

5. Save the file.

Section 7: Editing Landscaping Elements

In two exercises, this section covers the following processes in the landscape design project:

- Inserting gate symbols (pg 95)
- Moving landscape objects (pg 96)
- Reshaping plant groupings (pg 97)
- Modifying multiple plants (pg 99)
- Changing plant groupings (pg 100)
- Aligning plant tags (pg 100)
- Updating the Plant List worksheet (pg 101)

In these exercises, you use different methods to modify the planting layout and refine the landscaping design.

Exercise 19: Moving and Reshaping Landscape Objects

In this exercise, you modify the design by inserting gate symbols in the privacy fence. You then move the gazebo and modify the plants to allow access through the gate.

The completed exercise is shown in the following figure:

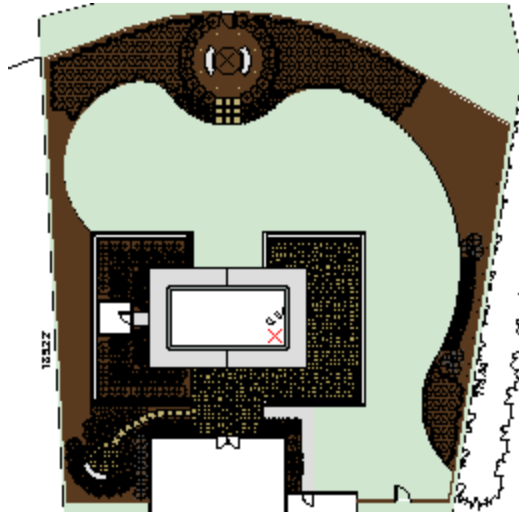

Inserting gate symbols

You start the exercise by inserting gates in the privacy fence.

1. If you did not complete Exercise 18—or you are unsure of your file's accuracy—open the **GS-VWLx18.vwx** file.
2. In the Navigation palette:
 - Activate the **03-Working-Beds** saved view (twice if necessary), and then activate the **Rotated Top** saved view.
 - Turn off visibility of the **Surfaces** layer.
3. In the Resource Browser, scroll down and open the Symbols/Plug-In Objects folder. Double-click the **Fence Gate** symbol, and insert one instance in the straight wall segment near the garage (shown highlighted at left), and one in the round wall segment at the gazebo (shown highlighted at right). Zoom in as necessary, and make sure both symbols are inserted in the wall.

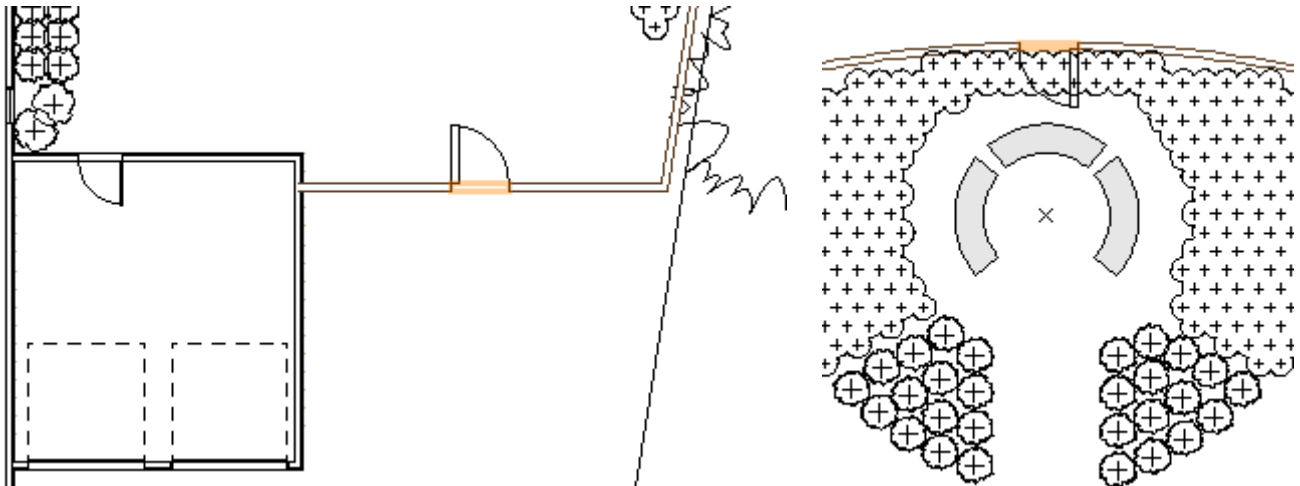

4. In the Navigation palette, turn on visibility of **Architecture** layer. Notice the interference with the gate swing and the gazebo, as shown.

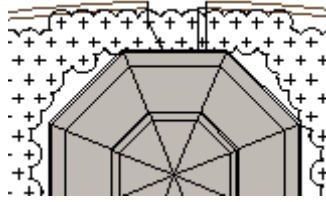

Moving landscape objects

Next, you provide clearance for the gate swing and access to the rear fence gate by moving the gazebo, adjacent plants, and one of the curved benches.

5. Press Ctrl+Alt+L to toggle off **Stack Layers** viewing mode. In the Navigation palette, select **Show/Snap/Modify Others** from the Layer Options drop down list, and then turn off visibility of the **Roof-Main** class. Press the X key, and then hold down the Shift key and select the gazebo and all three benches to add them to the current selection (select the Object Info palette's Shape tab, and verify that 4 objects are selected). Press Ctrl+M for the **Move** command shortcut, and then adjust settings (-1.50' [-.457m]) in the Move Selection dialog box, as shown at center. Click **OK** to move the objects away from the fence and eliminate the interference, as shown at right.

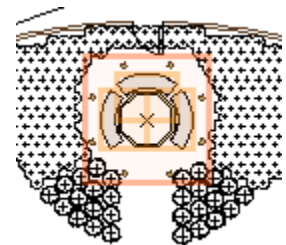
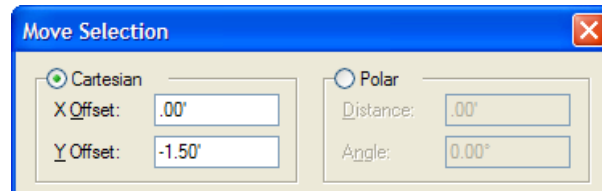
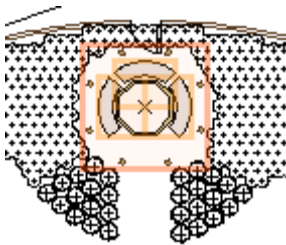

Next, you use the **Move by Points** tool to move the rear bench from the center of the gazebo to the center of the garden patio.

6. In the Navigation palette, turn on visibility of the **Surfaces** layer. Press the X key twice, and then select the rear bench (shown at left). Press Shift+M for the **Move by Points** tool shortcut. Click the insertion point of the gazebo, and then click the center point of the garden patio (circular hardscape), to move the bench where shown at center. With the bench still selected:
- Zoom in on the garden patio, and then press Shift+X for the **3D Selection** tool shortcut (to activate a 3D view).
 - In the Object Info palette, change the Z value to 0 (zero), and press Enter.
 - Press the X key and click **Previous View**  in the View bar to restore the 2D view.
 - Press Alt+= for the **Rotate** tool shortcut. Snap to the bench's insertion point to specify the rotation center. Click anywhere above the bench, and then move the cursor as necessary and click again to rotate the bench into position (between the May Night Salvia plants), approximately where shown at right.

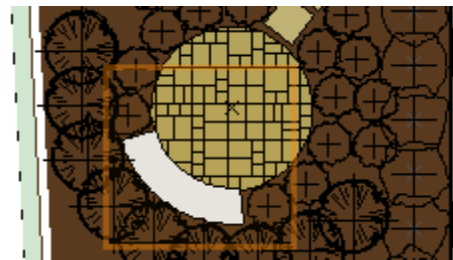



Reshaping plant groupings

Now that the gazebo is also a point of access, you reshape the surrounding groundcover to provide clearance. You then enhance the gazebo's perimeter by creating a circular plant pattern.

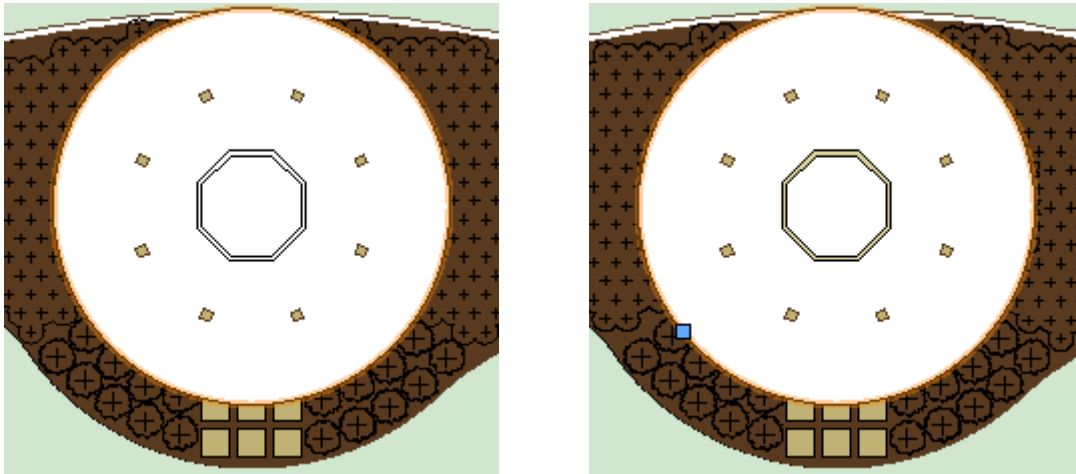
7. Zoom in on the gazebo, and then press the 6 key for the **Circle** tool shortcut. Draw a circle with a 27.50' [8.382m] diameter, starting from the center (insertion point) of the gazebo, as shown at left. Press the X key, then hold down the Shift key and select the groundcover plant object to add it to the selection (2 objects should now be selected). Right-click the selection and select **Clip Surface** from the context menu (leave the circle selected for the next step) to resize the plant groups, as shown at right.



8. In the Object Info palette, change the circle's diameter to 23.5' [7.163m], and then press Enter. Clear the selection, and then click the **Place Plant** tool . Enable **Poly-Edge Spaced Mode** , and then activate the **Red Knock Out Rose** Plant ID. Start near the stepstones and snap to the circle edge (press the T key) to create curved plant groups on both sides of the gazebo, as shown (highlighted) at left. Delete the circle, and examine the new plant configuration, as shown at right.

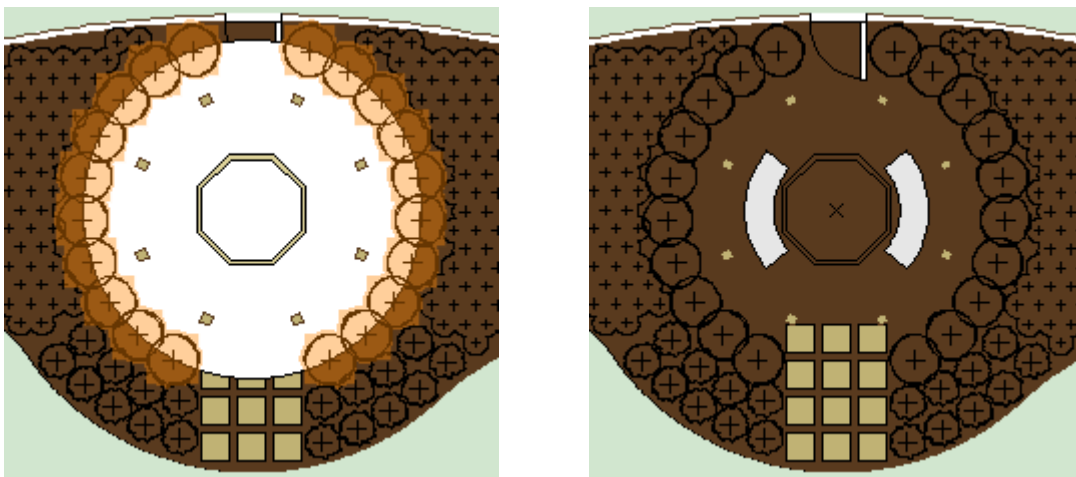

Note: You can alternately create one of the curved plant groups, and then mirror-duplicate the other.

Next, you complete the design change by removing three of the stepstones, and adjusting other plant instances, if necessary.

9. Press the X key, and then hold down the Shift key and select the main planting bed and the three stepstones closest to the gazebo. Right-click the selection, and then select **Add Surface** from the context menu. The three stepstones are “consumed” by the landscape area (only 9 remain), and their holes are filled. Clear the selection, and then delete any interfering plant instances (if necessary), as shown at left. Press Ctrl+6, and then zoom in on the landscaped area and examine all changes, as shown at right.

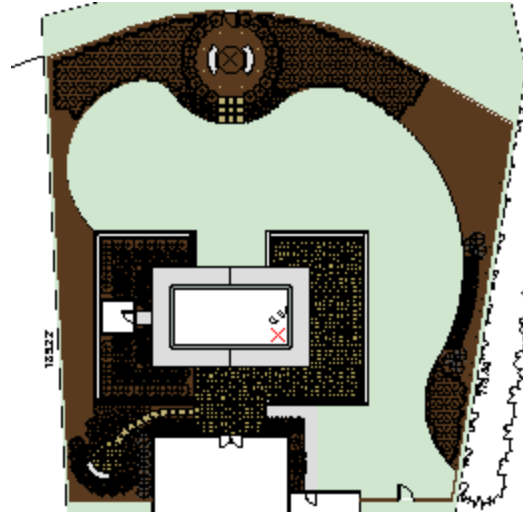
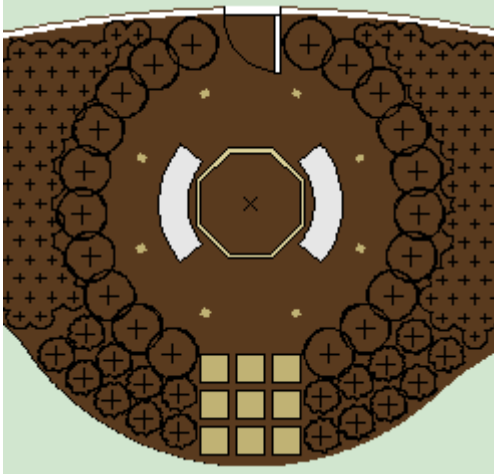

10. Save the file.

Exercise 20: Modifying Multiple Plant Objects

In this exercise, you edit various elements to complete the landscaping design.

The completed exercise is shown in the following figure:

Plant List					
	Common Name	Botanical Name	Qty	Price Ea	Extended Total
3	Evergreen Trees		18		\$886.50
4.1	Colorado Spruce	Picea pungens	9	\$85.00	\$765.00
4.2	Emerald Green Arborvitae	Thuja occidentalis 'Emerald'	9	\$13.50	\$121.50
5	Trees		21		\$780.00
6.1	Bradford Pear	Pyrus calleryana	5	\$60.00	\$300.00
6.2	Flowering Crabapple	Malus	16	\$30.00	\$480.00
7	Shrubs		751		\$3558.50
8.1	Endless Summer Hydrangea	Hydrangea macrophylla 'Endless'	12	\$22.00	\$264.00
8.2	Nova Zembla Rhododendron	Rhododendron 'Nova Zembla'	13	\$22.00	\$286.00
8.3	Red Knock Out Rose	Rosa x 'Knock Out' (Red)	44	\$18.00	\$792.00
8.4	Wintercreeper	Euonymus fortunei	682	\$3.25	\$2216.50
9	Perennials		182		\$3276.00
10.1	Happy Returns Daylily	Hemeroallis 'Happy Returns'	68	\$18.00	\$1224.00
10.2	May Night Sage	Salvia nemorosa 'Mainacht'	114	\$18.00	\$2052.00
11	Ornamental Grasses		0		\$0.00
13	Vines		0		\$0.00
15	Aquatic Plants		0		\$0.00
17.1	Total		972		\$8601.00

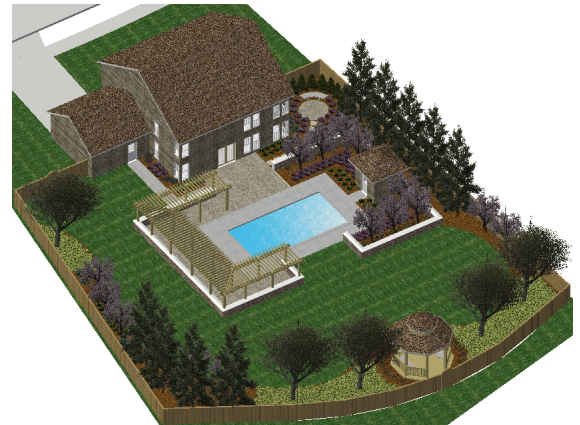

Modifying multiple plants

You start the exercise by using the **Custom Modification** command to simultaneously change the class of all plants proposed for the landscape design.

1. If you did not complete Exercise 19—or you are unsure of your file's accuracy—open the **GS-VWLx19.vwx** file.
2. From the menu, select **Tools > Custom Modification**. Adjust settings in the Custom Modification dialog box, as shown at left. Click **More Choices** and add the criteria, as shown at right. Click **OK** to display the Properties dialog box.

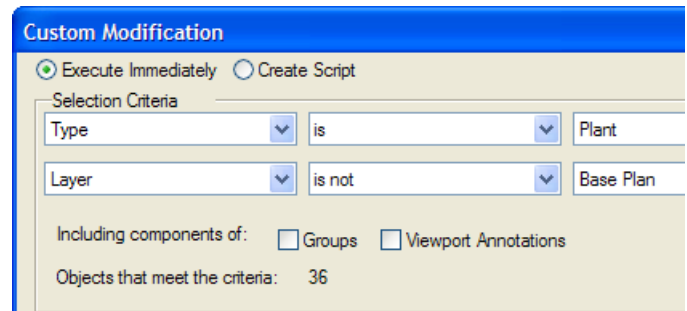
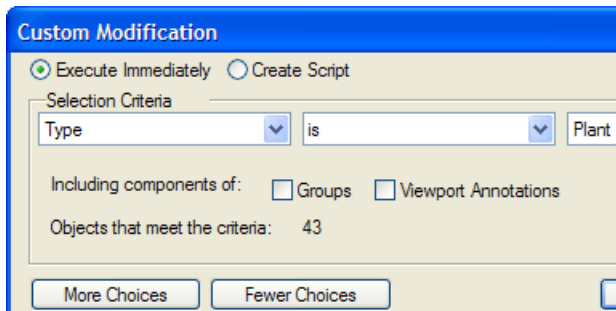

3. In the Properties dialog box, change the Class to **Plants-Proposed**, as shown, and then click **OK**. After several seconds, the class of all plant and tree objects (on different layers) is changed, even though some are not currently visible.

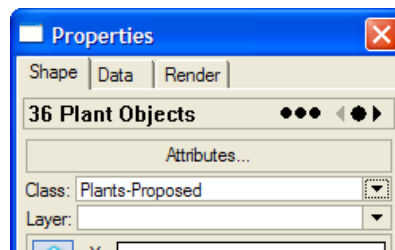

Changing plant groupings

Next, you use the **Change Plant Groupings** command to lock geometric plant patterns, combine similar plant groups, and to consolidate plant tags (which are currently invisible).

4. Hold down the Shift key, and select both groups of May Night Salvia plant groups near the gazebo (shown at left). From the menu, select **Landmark > Change Plant Grouping**. In the Choose Mode dialog box, enable the **Combine Plants into One Single Plant** option, and then click **OK** to combine them into a single plant object. Repeat the process to consolidate both red knock out rose plant groupings around the gazebo, and the other mirror-image plant groupings (shown at center highlighted for clarity). In the Navigation palette, turn on visibility of the **Upperstory** layer, and then repeat the process to consolidate the mirror-image tree groupings (notice that the class of the white crabapple tree objects is now Plants-Proposed), as shown at right.

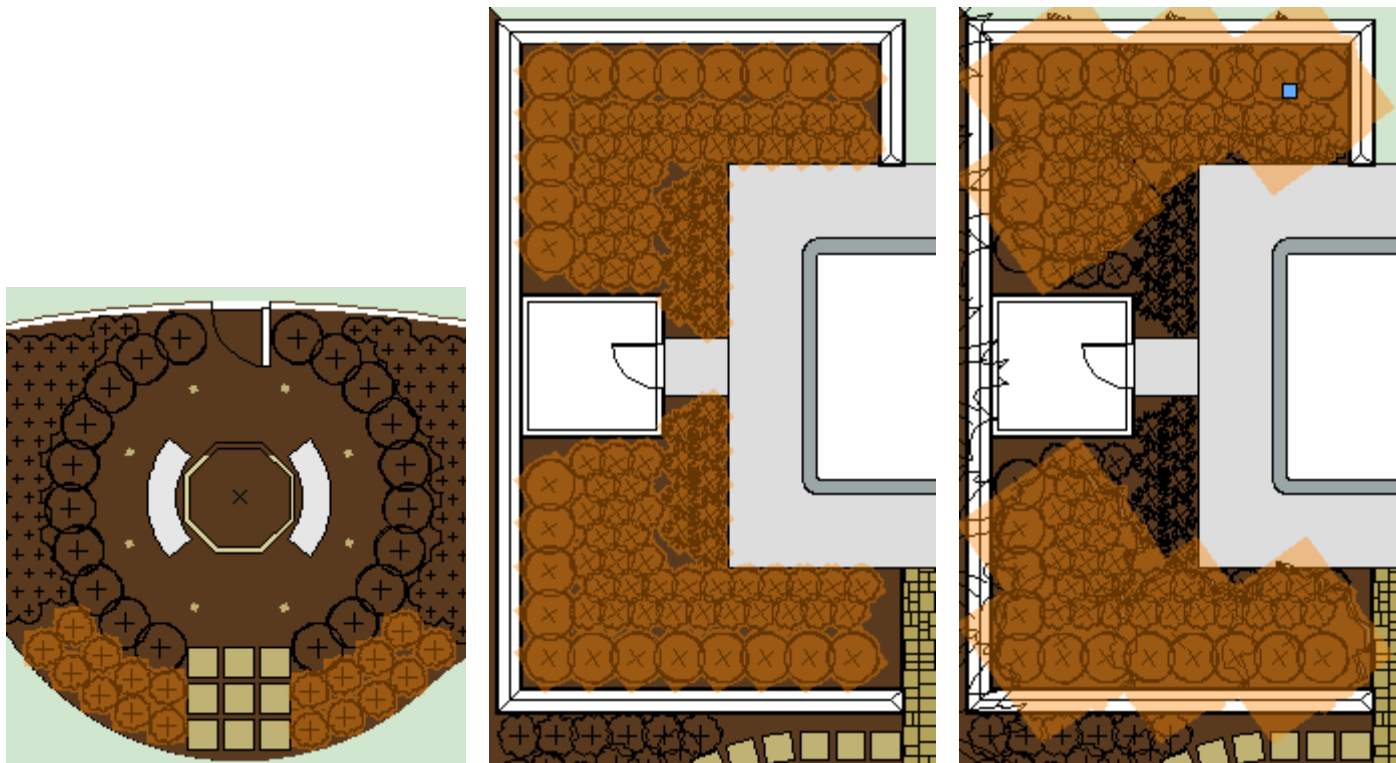

Aligning plant tags

Now that the final plant groupings are defined, you turn on visibility of the plant tags, and then you align tags on both sides of the plan for a more orderly appearance.

5. In the Navigation palette, turn on visibility of the **Plants-Component-Tags** class. All plant tags are now visible. Press 2 for the **Line** tool shortcut, and then hold down the Shift key and draw two vertical construction lines, approximately where shown.



6. Zoom and pan as necessary, and then align the plant tags similar to the configuration shown at left, by:
 - Changing the Tag Display to **Left** in the Object Info palette, as necessary (see Tip below figures).
 - Snapping the arrow grip (opposite the point) to the vertical construction lines. Press the T key on the vertical lines, or use the SmartCursor to acquire their endpoints to facilitate snapping.
 - Moving the arrow point and shoulder grips to resize, reposition, and align the shoulder lines horizontally (and vertically to align all tag bubbles). Copy the vertical lines, or use the SmartCursor to acquire snap points and then find the intersection of extension lines with the Align H and Align V snaps.

Delete the temporary construction lines, and then examine the aligned plant tags, as shown at right.



Tip: To speed up the tag alignment process for plants that take longer to regenerate, disable the **Enable 2D Plant Rendering** option in the Object Info palette before you align the tag, and then turn it back on afterwards.

Updating the Plant List worksheet

Next, you open the Plant List-Working Drawings worksheet, and then you update it to reflect the changes.

7. In the Resource Browser, scroll down and open the Worksheets section. Right click the **Plant List-Working Drawings** worksheet and select **Open** from the context menu. From the worksheet's drop-down menu, select **Recalculate**, and notice that there are now fewer line items (because of the plant grouping changes), and the quantity and cost totals now reflect the changes around the gazebo, as shown (you can compare the current cost with the [initial plant cost](#) in [Exercise 18](#)).

Plant List-Working Drawings @ 100%					
X ✓ \$18.00					
	A	B	C	D	E
1			Plant List		
2	Common Name	Botanical Name	Qty	Price Ea	Extended Total
3	Evergreen Trees		18		\$886.50
4.1	Colorado Spruce	Picea pungens	5	\$85.00	\$425.00
4.2	Colorado Spruce	Picea pungens	4	\$85.00	\$340.00
4.3	Emerald Green Arborvitae	Thuja occidentalis 'Emerald'	9	\$13.50	\$121.50
5	Trees		21		\$780.00
6.1	Bradford Pear	Pyrus calleryana	2	\$60.00	\$120.00
6.2	Bradford Pear	Pyrus calleryana	2	\$60.00	\$120.00
6.3	Bradford Pear	Pyrus calleryana	1	\$60.00	\$60.00
6.4	Flowering Crabapple	Malus	2	\$30.00	\$60.00
6.5	Flowering Crabapple	Malus	3	\$30.00	\$90.00
6.6	Flowering Crabapple	Malus	8	\$30.00	\$240.00
6.7	Flowering Crabapple	Malus	3	\$30.00	\$90.00
7	Shrubs		751		\$3558.50
8.1	Endless Summer Hydrangea	Hydrangea macrophylla 'Endless	3	\$22.00	\$66.00
8.2	Endless Summer Hydrangea	Hydrangea macrophylla 'Endless	3	\$22.00	\$66.00
8.3	Endless Summer Hydrangea	Hydrangea macrophylla 'Endless	6	\$22.00	\$132.00
8.4	Nova Zembla Rhododendron	Rhododendron 'Nova Zembla'	2	\$22.00	\$44.00
8.5	Nova Zembla Rhododendron	Rhododendron 'Nova Zembla'	2	\$22.00	\$44.00
8.6	Nova Zembla Rhododendron	Rhododendron 'Nova Zembla'	9	\$22.00	\$198.00
8.7	Red Knock Out Rose	Rosa x 'Knock Out' (Red)	24	\$18.00	\$432.00
8.8	Red Knock Out Rose	Rosa x 'Knock Out' (Red)	20	\$18.00	\$360.00
8.9	Wintercreeper	Euonymus fortunei	94	\$3.25	\$305.50
8.10	Wintercreeper	Euonymus fortunei	309	\$3.25	\$1004.25
8.11	Wintercreeper	Euonymus fortunei	279	\$3.25	\$906.75
9	Perennials		182		\$3276.00
10.1	Happy Returns Daylily	Hemoerocallis 'Happy Returns'	10	\$18.00	\$180.00
10.2	Happy Returns Daylily	Hemoerocallis 'Happy Returns'	27	\$18.00	\$486.00
10.3	Happy Returns Daylily	Hemoerocallis 'Happy Returns'	13	\$18.00	\$234.00
10.4	Happy Returns Daylily	Hemoerocallis 'Happy Returns'	18	\$18.00	\$324.00
10.5	May Night Sage	Salvia nemorosa 'Mainacht'	18	\$18.00	\$324.00
10.6	May Night Sage	Salvia nemorosa 'Mainacht'	66	\$18.00	\$1188.00
10.7	May Night Sage	Salvia nemorosa 'Mainacht'	14	\$18.00	\$252.00
10.8	May Night Sage	Salvia nemorosa 'Mainacht'	10	\$18.00	\$180.00
10.9	May Night Sage	Salvia nemorosa 'Mainacht'	6	\$18.00	\$108.00
11	Ornamental Grasses		0		\$0.00
13	Vines		0		\$0.00
15	Aquatic Plants		0		\$0.00
17.1	Total		972		\$8501.00

Next, you complete the worksheet by summarizing plant records.

- Click the row heading (such as 4.1) of any evergreen tree item to highlight the entire row, and then drag the SUM icon  onto the header of column A. The data is summarized by common names, as shown at left. Notice that the Price Ea and Extended Total values are wrong. Select either of the evergreen tree item headers and then drag the SUM icon onto the header of column D. The Price Ea and Extended Total values are now correct, as shown at right.

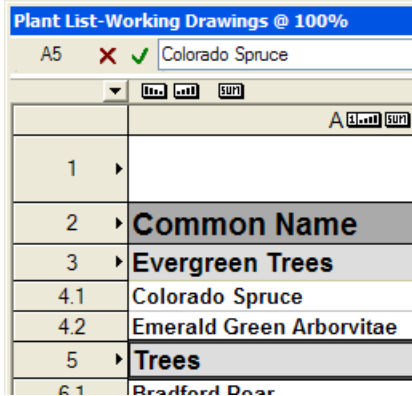

	A
1	
2	Common Name
3	Evergreen Trees
4.1	Colorado Spruce
4.2	Emerald Green Arborvitae
5	Trees
6.1	Bradford Pear

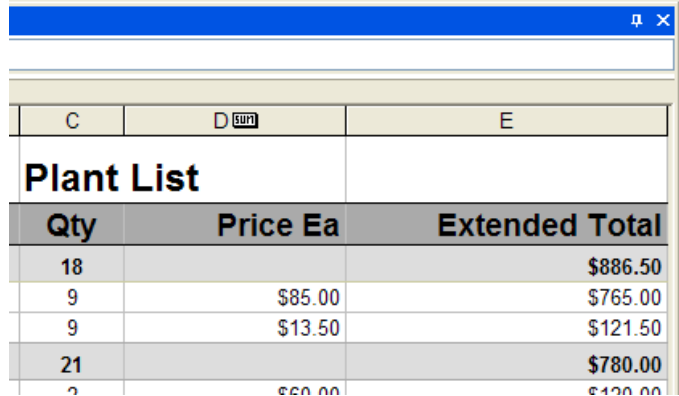

	C	D	E
	Plant List		
	Qty	Price Ea	Extended Total
	18		\$886.50
	9	\$85.00	\$765.00
	9	\$13.50	\$121.50
	21		\$780.00
	2	\$60.00	\$120.00

- Repeat the summarizing process for the Common Name and Price Ea columns for the Trees, Shrubs, and Perennials sections to complete the worksheet, as shown at left. Close the worksheet, and then activate the **Iso-Full** saved view (you may need to activate it twice), and then examine the completed planting bed and turf landscape areas, as shown at right.

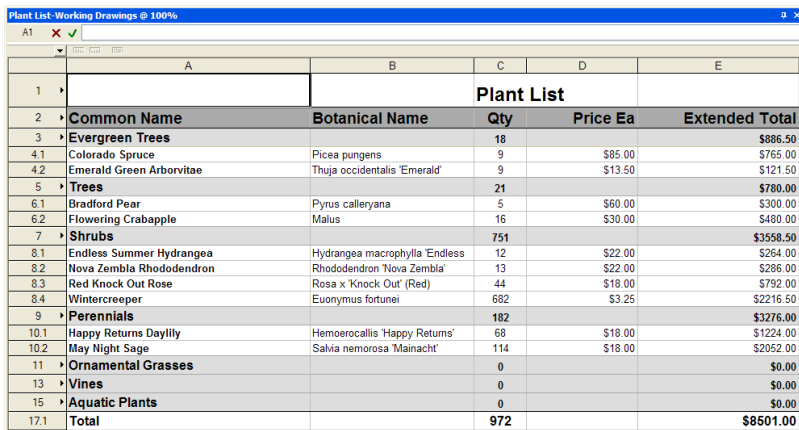

	A	B	C	D	E
1			Plant List		
2	Common Name	Botanical Name	Qty	Price Ea	Extended Total
3	Evergreen Trees		18		\$886.50
4.1	Colorado Spruce	Picea pungens	9	\$85.00	\$765.00
4.2	Emerald Green Arborvitae	Thuja occidentalis 'Emerald'	9	\$13.50	\$121.50
5	Trees		21		\$780.00
6.1	Bradford Pear	Pyrus calleryana	5	\$60.00	\$300.00
6.2	Flowering Crabapple	Malus	16	\$30.00	\$480.00
7	Shrubs		751		\$3558.50
8.1	Endless Summer Hydrangea	Hydrangea macrophylla 'Endless'	12	\$22.00	\$264.00
8.2	Nova Zembla Rhododendron	Rhododendron 'Nova Zembla'	13	\$22.00	\$286.00
8.3	Red Knock Out Rose	Rosa x 'Knock Out' (Red)	44	\$18.00	\$792.00
8.4	Wintercreeper	Euonymus fortunei	682	\$3.25	\$2216.50
9	Perennials		182		\$327.00
10.1	Happy Returns Daylily	Hemeroallis 'Happy Returns'	68	\$18.00	\$1224.00
10.2	May Night Sage	Salvia nemorosa 'Mainacht'	114	\$18.00	\$2052.00
11	Ornamental Grasses		0		\$0.00
13	Vines		0		\$0.00
15	Aquatic Plants		0		\$0.00
17.1	Total		972		\$8501.00

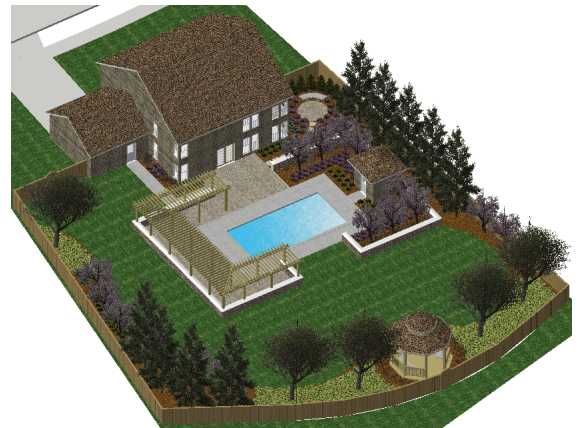

- Save the file.

Section 8: Creating Landscape Documentation

In three exercises, this section covers the following processes in the landscape design project:

- Rotating the viewport (pg 104)
- Adjusting viewport class visibilities (pg 105)
- Cropping the viewport (pg 105)
- Creating notes (pg 107)
- Creating callouts (pg 108)
- Placing the plant list worksheet on the drawing (pg 110)
- Resizing worksheet columns (pg 111)

In these exercises, you modify the landscape plan drawing's *viewport* (that display objects on multiple design layers) on a *sheet layer*. You then create commonly used annotation objects, and then you place the plant list on the sheet layer to complete the drawing.

Note: *Depending on the application, you create annotations in design layers or directly inside the viewport (in viewport annotation mode) based on suggested best practices.*

Exercise 21: Optimizing the Landscape Plan Drawing

In this short exercise, you optimize the landscape plan drawing for printing by rotating and cropping the existing viewport. You complete the exercise by changing the viewport's scale.

The completed exercise is shown in the following figure:

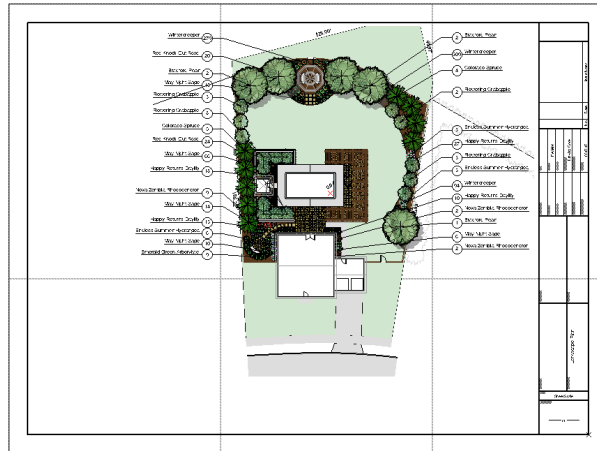

Rotating the viewport

You start the exercise by rotating the viewport so that the house is orthogonal to the drawing sheet.

1. If you did not complete Exercise 20—or you are unsure of your file's accuracy—open the **GS-VWLx20.vwx** file.
2. In the Navigation palette, activate the **Sheet Layer-Landscape Plan** saved view. After several seconds, the full color fill for all plants is displayed, as shown at left. Zoom in on the pool house (leave the viewport selected). From the Basic tools palette, click the **Rotate** tool . Snap to the pool house wall's top left inside corner, and then snap to wall's top right inside corner. Start moving the cursor up, and then hold down the Shift key for the Horizontal constraint and click to complete the rotation when your cursor looks similar to the one shown at center. Press Ctrl+6 to see the entire rotated viewport.

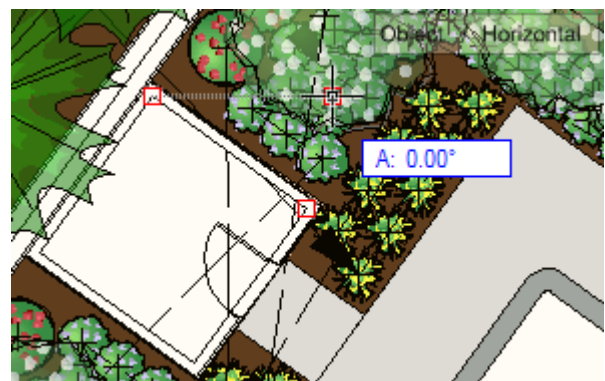
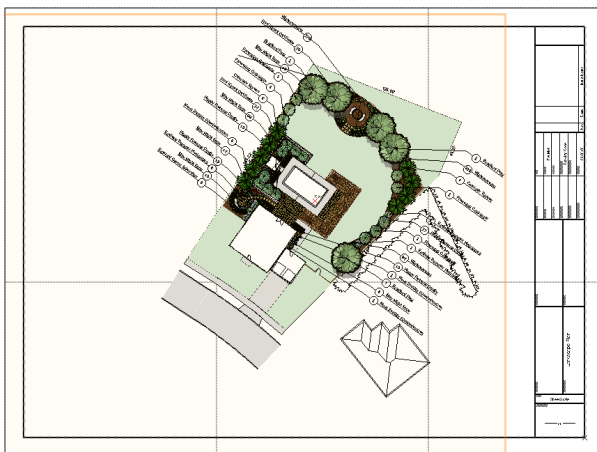

Notes:

- 1) The viewport's original position and orientation is identical for viewports on all sheet layers in the starting file.
- 2) It's not necessary for this tutorial, but you can hide the text displayed inside the pool by either moving the property line's area text grip, or by creating a solid fill for the pool (right-click the **Pool** symbol in the Resource Browser and select **2D Component** in the Edit Symbol dialog box, then use the **2D Polygon** tool's **Polygon from Inner Boundary Mode**).

Adjusting viewport class visibilities

Next, you change the Roof-main class to gray so you can see through all roofs, and then you override the pen color of the Existing-remain class to de-emphasize the existing vegetation in the neighbor's yard.

- In the Object Info palette, click **Classes**. In the Viewport Class Properties dialog box:
 - Change the Roof-Main class to **Gray**.
 - Select the **Existing-remain** class, and then click **Edit**. In the Edit Class(es) dialog box, change the Pen Color to gray, as shown at left. Click **OK** to override the class color, and then click **OK** to incorporate the class changes.

The house, garage, pool house, and gazebo roofs are now visible, and you can now see objects below them, as shown at right.

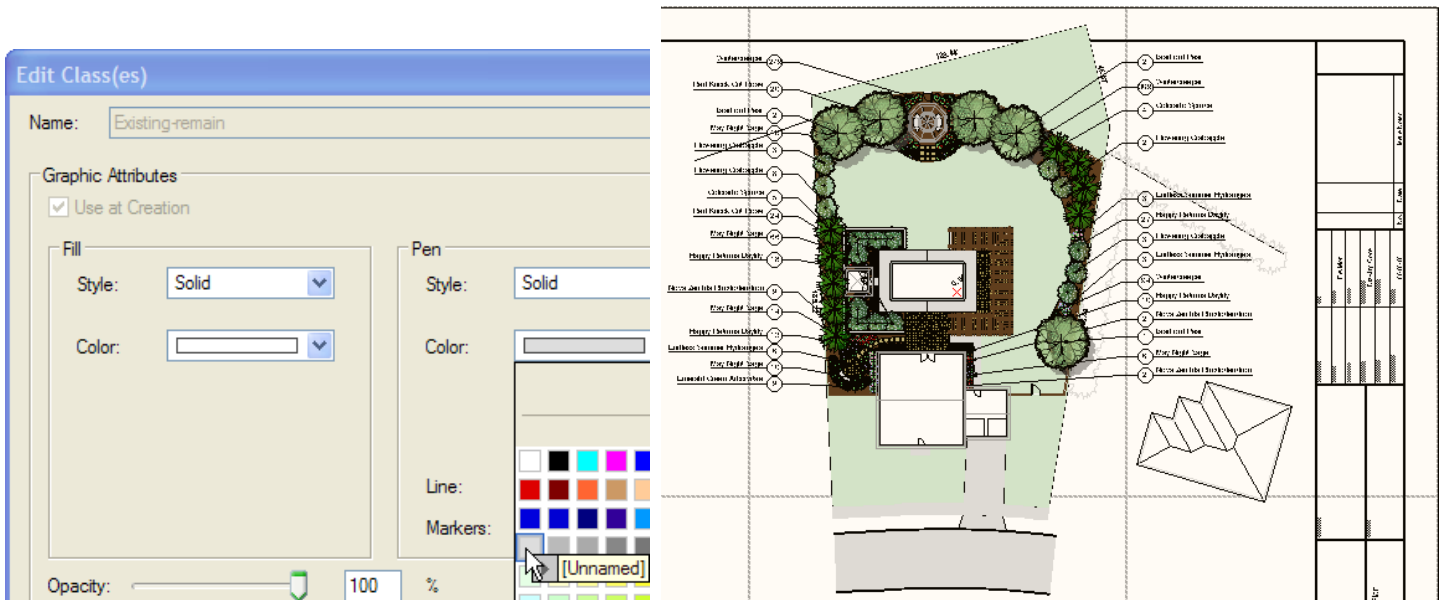

Cropping the viewport

Next, you crop the rotated viewport to hide extraneous objects, and save space so you can display it at a larger scale.

- Double-click any object in the viewport to activate editing mode. In the Edit Viewport dialog box, select the **Crop** option as shown at left, and then click **OK** to enter Viewport Crop mode. Zoom in on the viewport objects. From the Basic tools palette, click the **2D Polygon** tool. Activate **Polygon From Vertices Mode**, and then draw a closed polygon, approximately where shown at right to crop the viewport.

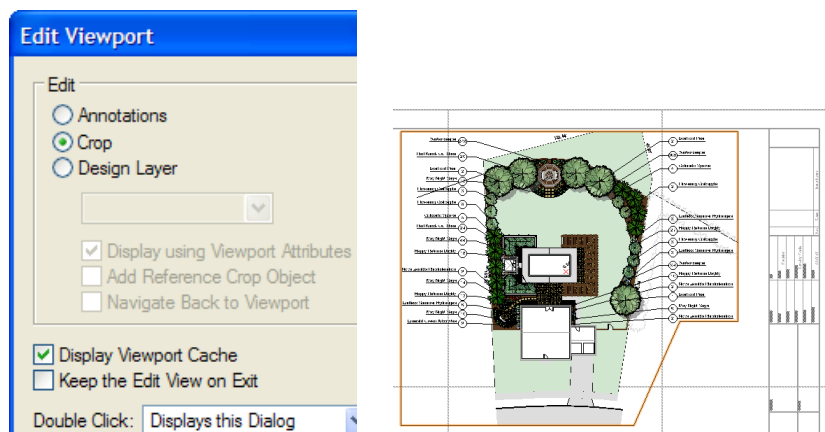

- In the Attributes palette, change the Pen Style to **None**, and then click **Exit Viewport Crop** to return to the sheet layer. In the Object Info palette, select **1:200** from the Scale drop-down list, and then press the X key and drag the cropped viewport into its final position approximately where shown, and then clear the selection.

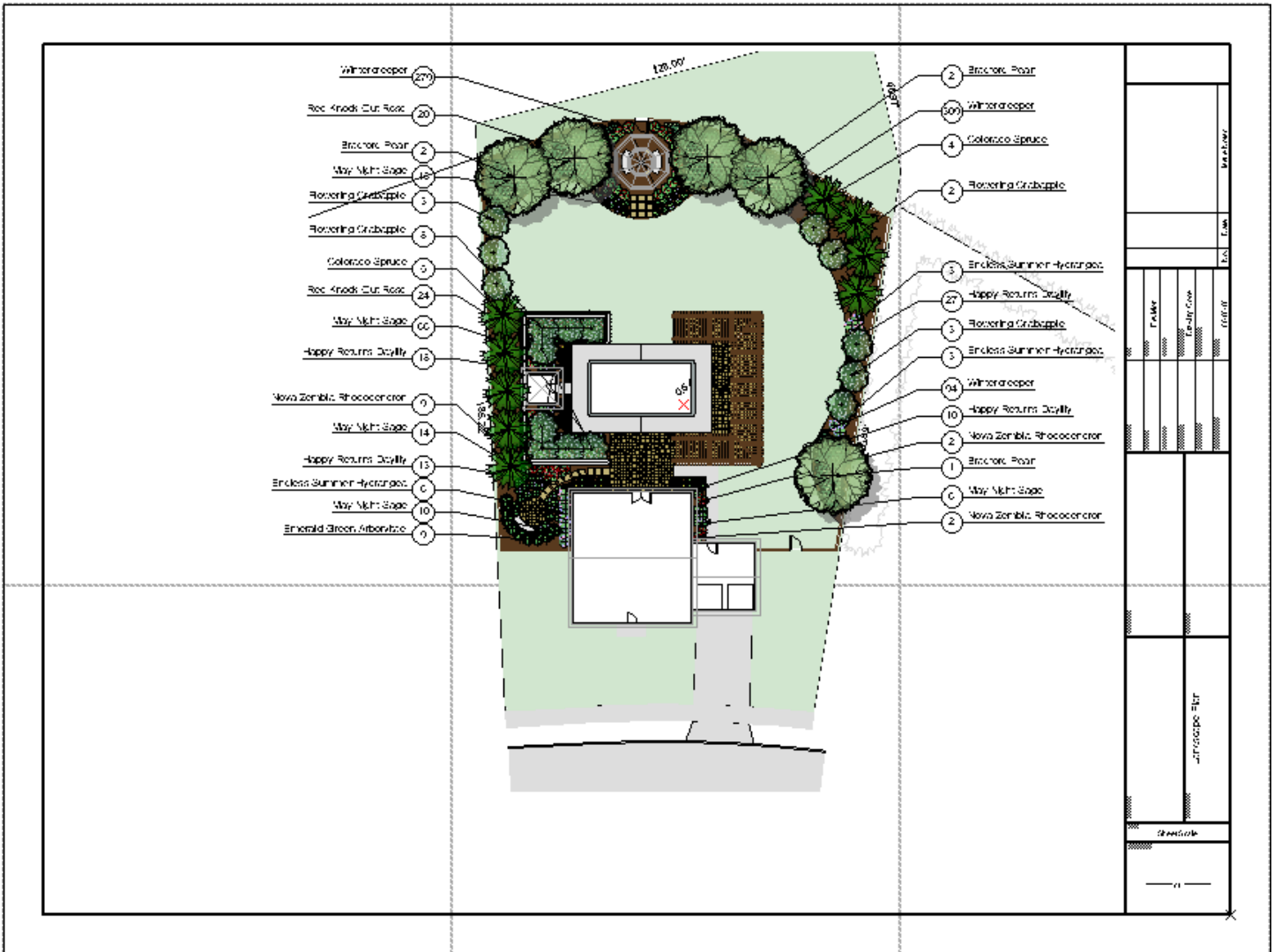





- Save the file.

Creating callouts

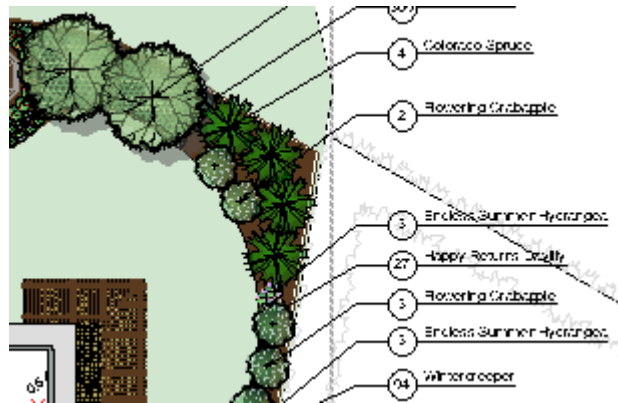
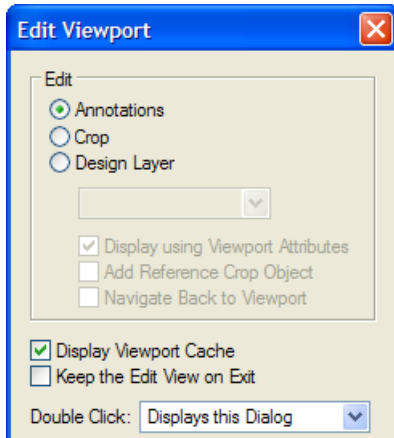
Next, you activate Viewport Annotation mode, and then you create callouts to identify two of the constructed elements.

- In the View bar, click **Fit to Page Area**  to display entire drawing. Double-click any object in the viewport to activate editing mode. In the Edit Viewport dialog box, select the **Annotations** option and then adjust other options if necessary, as shown at left. Click **OK** to enter Viewport Annotation mode, and then zoom in on the area shown at right.



- From the Basic tools palette, the **Callout** tool . Make sure the **Towards target mode**  and **Two-point mode**  options are active. Click **Callout Tool Preferences** , and adjust settings (.17' [51.82mm], .02' [6.10mm]) in the Callout Preferences dialog box, as shown, and then click **OK** to save the settings.

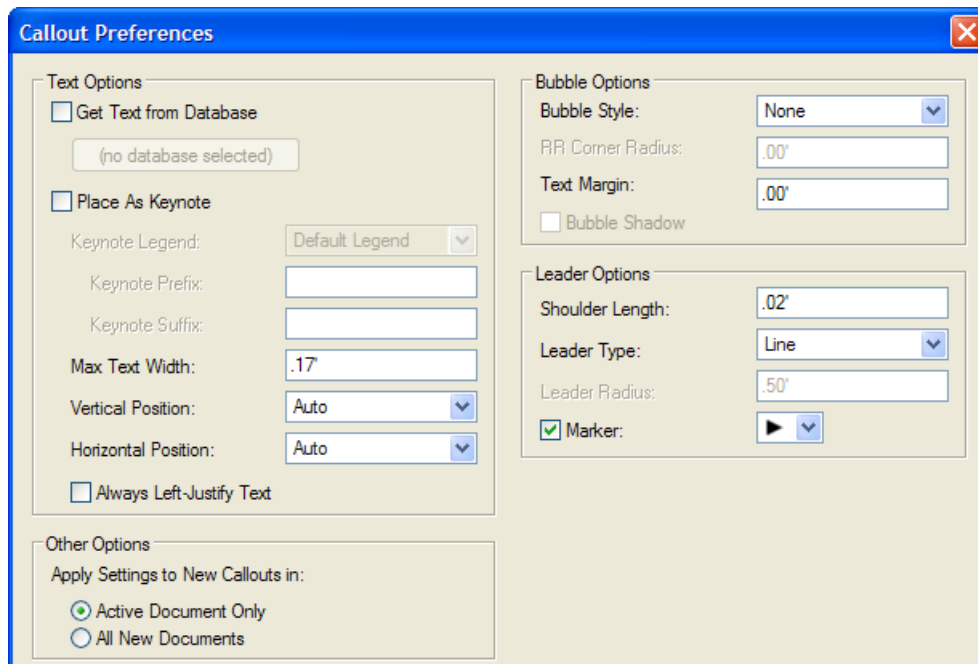

Getting Started with Vectorworks Landmark

- Click two points in order—start aligned with the plant tags, and then snap the second point to a pergola rafter—approximately where shown at left, and then enter the callout text, as shown at center. Click **OK** to place the callout in the drawing, similar to the one shown at right.

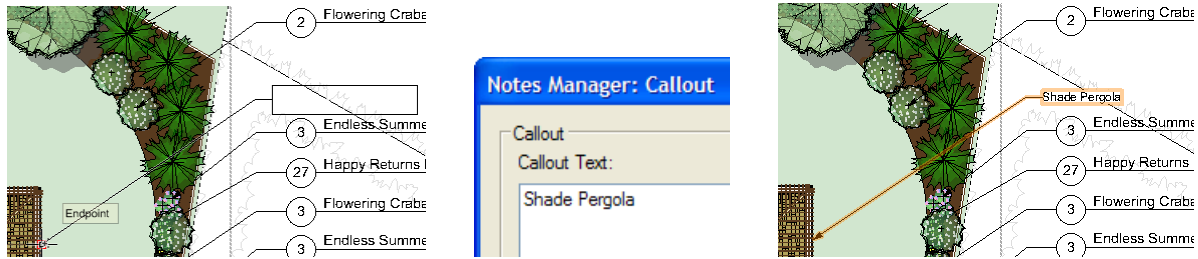

Next, you use the Ctrl+drag method to copy the callout and then you reposition the arrow and change the text for other constructed element.

- From the menu, select **Text > Size > 14** to match the size of the plant tags. Press the X key, and then start dragging the callout you just created, and then hold down the Ctrl and Shift keys to create a vertically aligned copy, as shown at left, and then:
 - Snap the arrow point grip to the flagstone patio.
 - Double-click the callout and change the text, as shown at center, and then click **OK**.
 - Press the X key twice to clear the selection, and then examine the completed callouts, as shown at right.

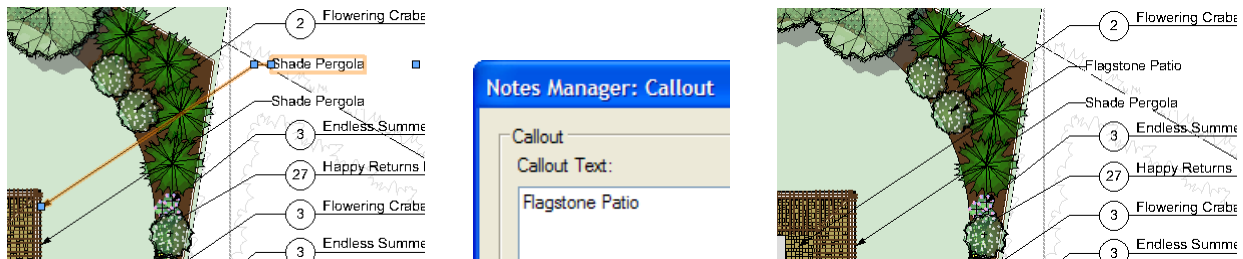

Note: To save time, you skip the repetitive process of creating callouts for other constructed elements.

- Click **Exit Viewport Annotation**, clear the selection, and then examine the completed annotations, as shown.

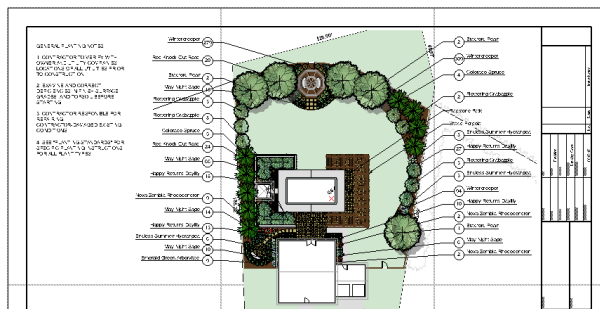

- Save the file.

Exercise 23: Working with Plant Schedules

In this short exercise, you place the plant list on the landscape plan drawing.

The completed exercise is shown in the following figure:

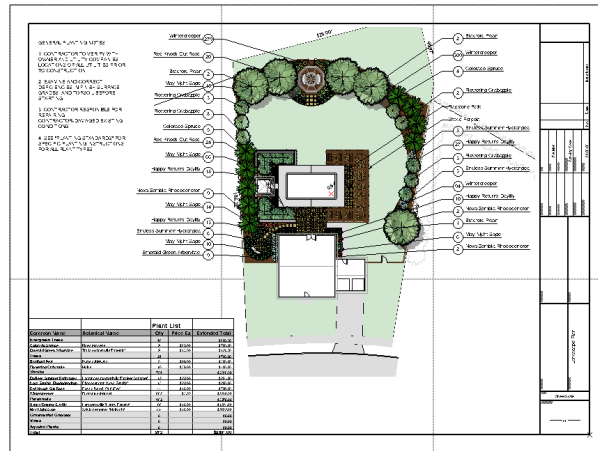

Placing the plant list worksheet on the drawing

You start the exercise by placing the plant list worksheet on the drawing.

1. If you did not complete Exercise 22—or you are unsure of your file's accuracy—open the **GS-VWLx22.vwx** file.
2. In the Resource Browser, scroll down and open the Worksheets section. Double-click the **Plant List-Working Drawings** worksheet to place it in the default location (centered) in the drawing, as shown at left. Drag the worksheet by its lower left corner, and then snap it to the drawing border's lower left inside corner. Right-click the worksheet and select **Send > Send to Back** to place it behind the drawing border, as shown at right. Notice that the worksheet interferes with the landscaping plan.

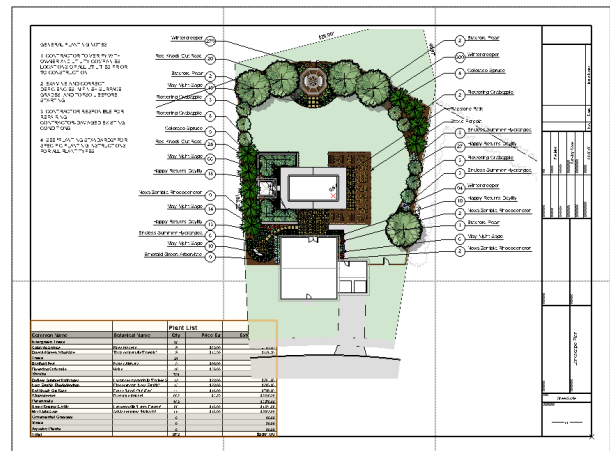
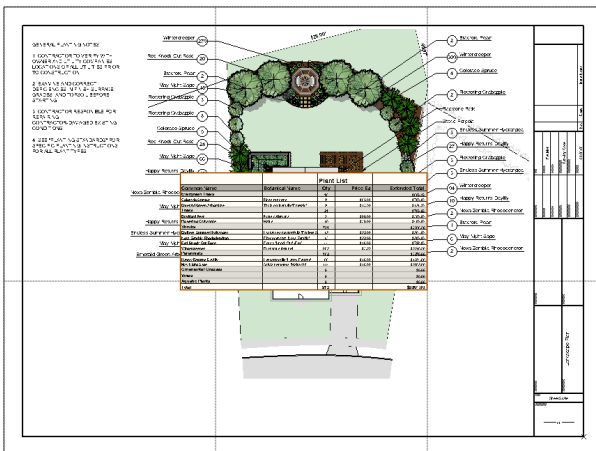

Resizing worksheet columns

Next, you adjust column widths to display missing text or eliminate the interference with the viewport.

3. Double-click the worksheet to open it. Drag the right edge of the B column header to increase its width until all text is visible, and then drag the right edge of the A, D, and E column headers to reduce their width, as shown at left. Close the worksheet to update the plant list, and then clear the selection and examine the completed landscape plan drawing, as shown at right.

Plant List					
	A	B	C	D	E
1					
2	Common Name	Botanical Name	Qty	Price Ea	Extended Total
3	Evergreen Trees		18		\$886.50
4.1	Colorado Spruce	Picea pungens	9	\$85.00	\$765.00
4.2	Emerald Green Arborvitae	Thuja occidentalis 'Emerald'	9	\$13.50	\$121.50
5	Trees		21		\$780.00
6.1	Bradford Pear	Pyrus calleryana	5	\$60.00	\$300.00
6.2	Flowering Crabapple	Malus	16	\$30.00	\$480.00
7	Shrubs		751		\$3558.50
8.1	Endless Summer Hydrangea	Hydrangea macrophylla 'Endless Summer'	12	\$22.00	\$264.00
8.2	Nova Zembla Rhododendron	Rhododendron 'Nova Zembla'	13	\$22.00	\$286.00
8.3	Red Knock Out Rose	Rosa x 'Knock Out' (Red)	44	\$18.00	\$792.00
8.4	Wintercreeper	Euonymus fortunei	682	\$3.25	\$2216.50
9	Perennials		182		\$3276.00
10.1	Happy Returns Daylily	Hemeroallis 'Happy Returns'	68	\$18.00	\$1224.00
10.2	May Night Sage	Salvia nemorosa 'Mainacht'	114	\$18.00	\$2052.00
11	Ornamental Grasses		0		\$0.00
13	Vines		0		\$0.00
15	Aquatic Plants		0		\$0.00
17.1	Total		972		\$8501.00

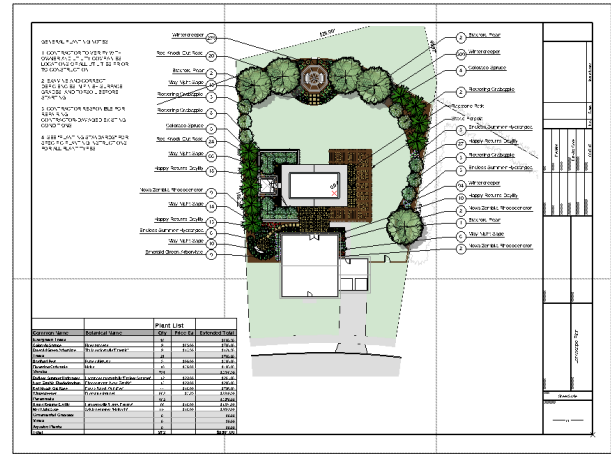

4. Save the file. Congratulations - you have now completed the tutorial!

Nemetschek North America, Inc.
7150 Riverwood Drive, Columbia, MD 21046-1295 USA
www.vectorworks.net | T 410-290-5114 | F 410-290-8050

©2009 Nemetschek North America, Inc.
Vectorworks is a registered trademark of Nemetschek North America, Inc.
Renderworks is a trademark of Nemetschek North America, Inc.

Parasolid is a registered trademark of Siemens PLM Software.



Courtesy of PWP Landscape Architecture.